

# UNIVERSAL

03/2005

Universal Programme  
Programma Universale  
Universal Program

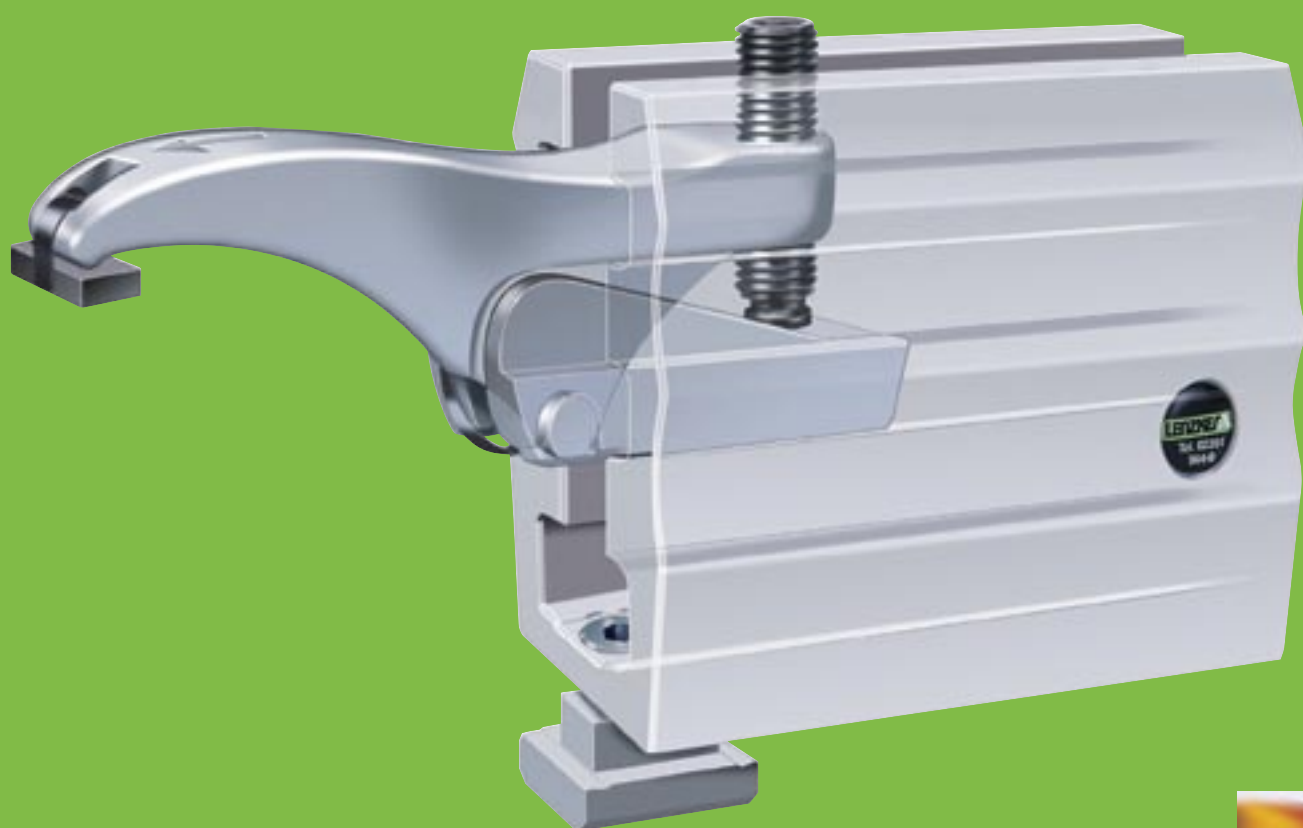

**LENZKES** 



Universal Clamping Tools  
Tecnica di Fissaggio Universale  
Universell Spänntechnik

# PROGRAMME 2000

# Examples of application Esempi d'uso Möjligheternas mästare



MQ 100



S 20



MQ 110/130



MQ 100



MQ 110/130



S 30



MQ 110/130



S 30/B 50



MQ 70



MQ 130



MQ 60/B 50



MQ 100



SKQ 10

- **Universal problem solutions** for all T slots or tapped holes.
- **Strong clamping pressure** for small clamping torque.
- **Strong clamping pressure** through stackable clamping shoes and extension blocks.
- **Highly adjustable** through integrated sliding plate.
- **Fast clamping, short set-up time, quick release action.**
- **Stepless adjustability horizontal and vertical.**
- The **clamping tools** of the series MQ may also **be used as an extension** to the work table.
- **Durability** through **static stress** of threads.

- **Universale soluzione** di problemi per tutti i piani di lavoro con guide e foro filettato.
- **Molta forza di fissaggio** con una minima forza di chiusura.
- **Elevata altezza di fissaggio** tramite sovrapposizione della scarpa/ceppo e dei distanziali.
- **Molta regolabilità** tramite una piastra integrata.
- Fissaggio **rapido, brevi tempi di preparazione pronto sblocco** del pezzo fissato.
- **Fissaggio di continuo sia in orizzontale che in verticale.**
- Gli **elementi di fissaggio** della serie MQ **possono fuoriuscire** per circa la **metà** dal piano di lavoro.
- **Lunga durata** tramite peso **statico** della filettatura.

- **Universell problemlösare** för alla maskintyper med T-spår eller gängat hål.
- **Hög spännkraft** med lågt vridmoment.
- **Hög spännhöjd** genom stapelbarhet av spännsko samt förhöjningsblock.
- **Stor flexibilitet** genom integrerad förlängningsplatta.
- **Snabb fastspänning, kort ställtid, snabb lossgöring** av arbetsstycket.
- **Steglös ställbarhet horisontellt och vertikalt.**
- **Spännelement** av serien MQ kan appliceras med **halva** spännskon **utanför maskinbordet.**
- **Lång livslängd** pga **statisk belastning** av gängan.

Lenzkes Clamping tools may be requested free of charge and without obligation to purchase. An ideal offer for the practitioner. Please call and request a free trial.

Gli elementi di fissaggio Lenzkes possono essere provati gratuitamente senza obbligo di acquisto. Un'offerta ideale per l'utilizzatore. Telefonate e richiedete una prova.

Lenzkes spännelement kan beställas som prov kostnadsfritt och utan avgifter. Var vänlig ring beställ och prova.

# Stepless clamping tools MQ 100, MQ 110 and MQ 130

## Elementi di fissaggio di continuo MQ 100, MQ 110, MQ 130

## Steglösa spännelement MQ 100, MQ 110 och MQ 130

**The clamping tools of the new generation MQ100, MQ110 and MQ130 are the universal problem solution for all machine tables.**

- Flexible and adjustable at every angle to the T slot.
- Reduction of set-up time through reliable, fast and safe clamping.
- Vertically highly adjustable through triple clamping shoe.
- Widely adjustable clamping heights through stackable clamping shoe.
- Clamping shoes may be used as an extension to the work table.

**Gli elementi di fissaggio della nuova Generazione MQ100, MQ110, MQ130 sono la soluzione a problemi su tutti i piani di lavoro.**

- Flessibili in ogni angolo delle cave-T/Guide.
- Riduzione dei tempi di preparazione con fissaggio svelto e sicuro.
- Maggiore regolazione in verticale con scarpe triple.
- Maggiore altezza di fissaggio con scarpe sovrapponibili.
- Le scarpe possono fuoriuscire dal piano di lavoro della macchina.

**Är den nya generationen spännelement MQ100, MQ110 och MQ130 är den universiella problemlösaren för alla maskiner.**

- Flexibel i alla vinklar till T-spår.
- Reducerar ställtider genom pålitliga, snabba och säkra fastspänningar.
- Stor vertikal inställningsmöjlighet genom 3-faldig spännsko.
- Höga spännhöjder genom stapelbarhet av spännsko.
- Skon kan appliceras utanför maskinbordet.



Horizontally highly adjustable through integrated sliding plate.

Maggiore regolazione in orizzontale tramite una piastra integrata.

Stor horisontell inställningsmöjlighet genom integrerad förlängningsplatta.

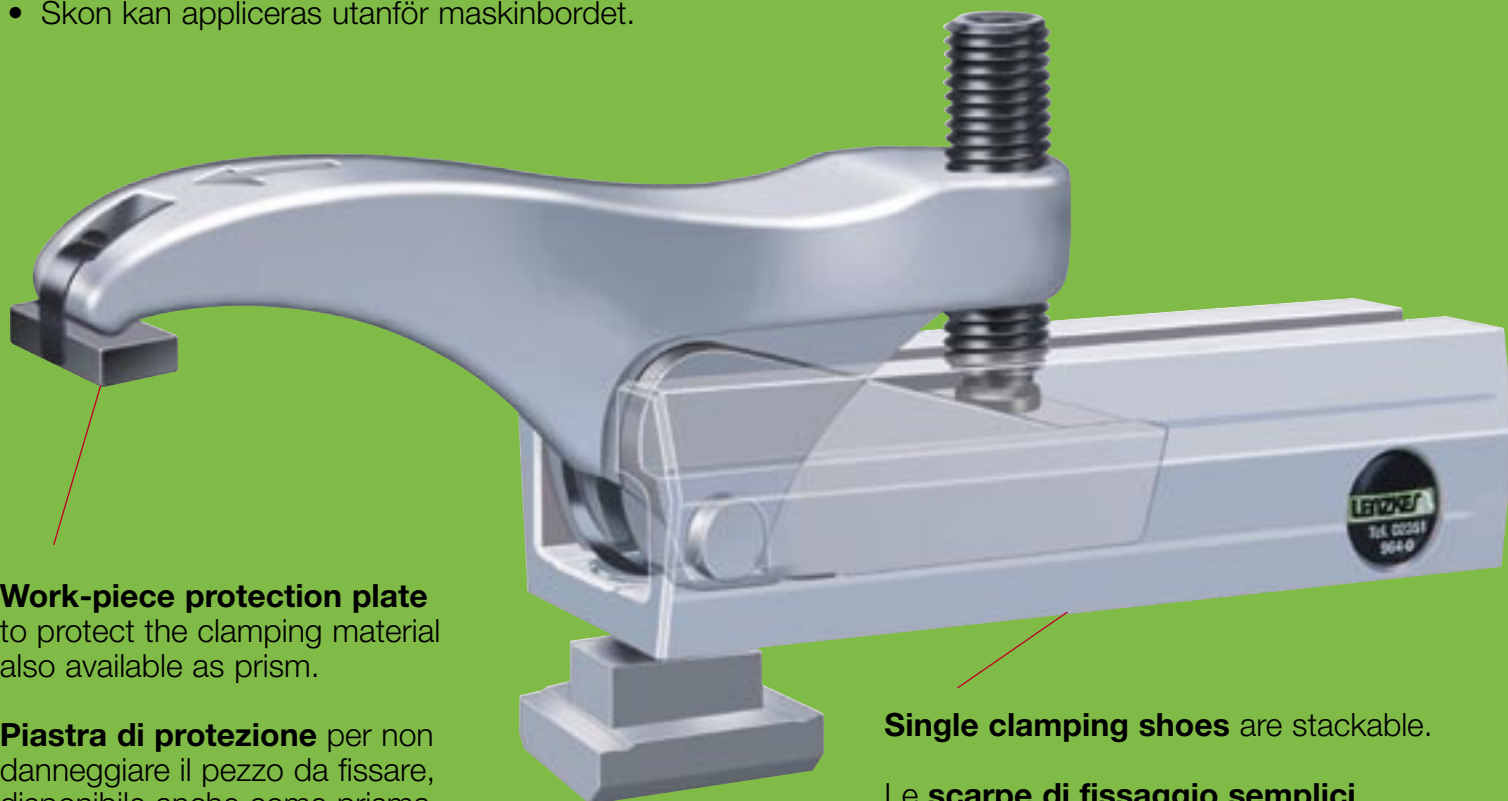

**Work-piece protection plate** to protect the clamping material also available as prism.

**Piastra di protezione** per non danneggiare il pezzo da fissare, disponibile anche come prisma.

**Platta för skydd** av verktyget. Levereras även som prisma.

**Single clamping shoes** are stackable.

Le **scarpe di fissaggio semplici** sono sovrapponibili.

**Enfack-spännsko** är stapelbar.

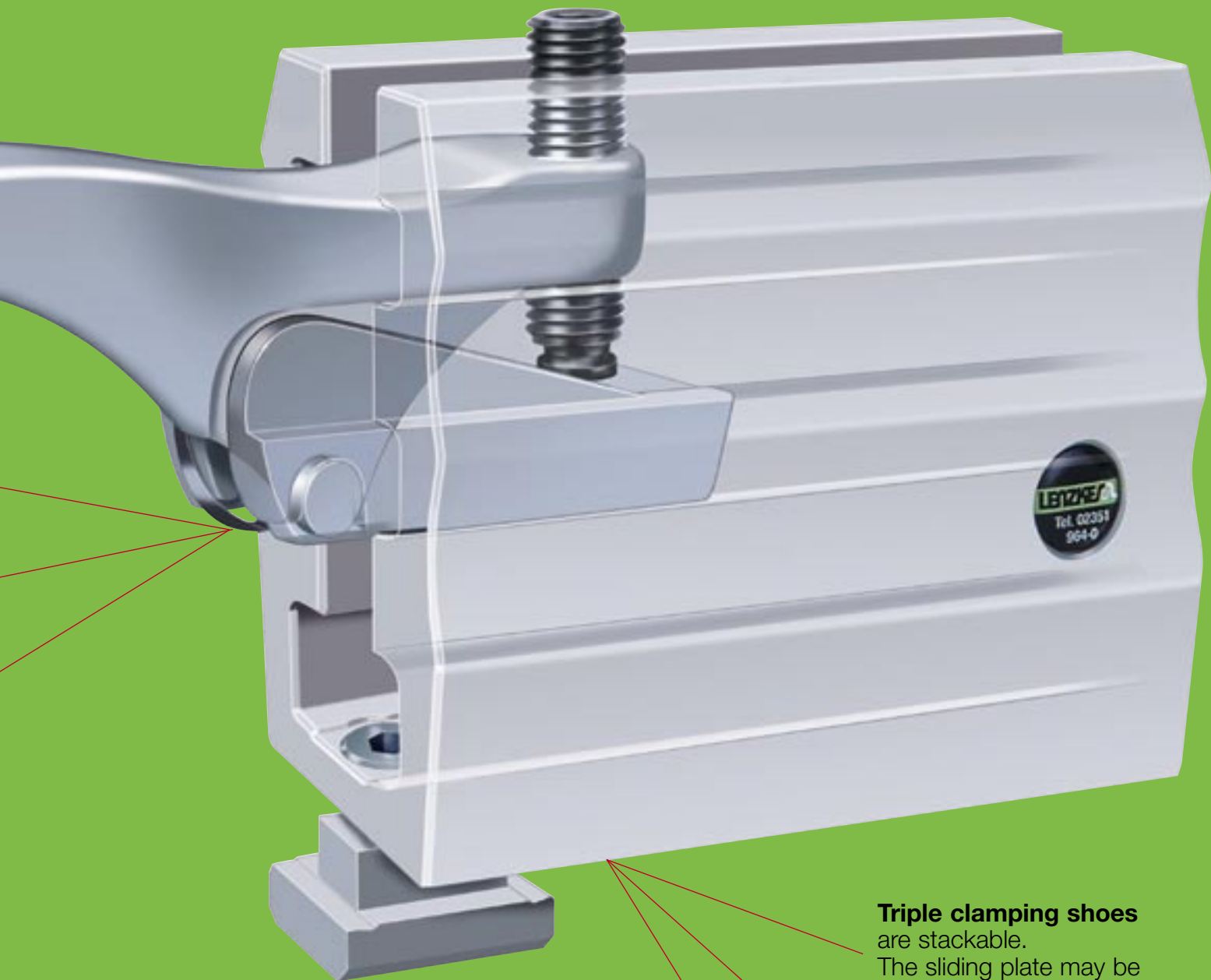

#### Extension nuts

- for clamping in T nut according to DIN 650,
- for stacking to clamping shoes for vast clamping heights,
- may be removed for use on machine tables with tapped holes.

#### Tassello di montaggio

- per fissaggio nelle guide secondo DIN 650,
- per sovrapporre le scarpe per altezze piu elevate.
- può essere svitato per uso su piani con foro filettato.

#### Förlängningsmutter

- för fastspänning i T-spår enligt DIN 650,
- för stapling av spännsko för höga spänshöjder,
- kan skruvas bort vid användning, i maskiner med gängat bord.

**Triple clamping shoes** are stackable.

The sliding plate may be used for all three options.

**Le scarpe di fissaggio triple** sono sovrapponibili. La piastra integrata con la leva può essere inserita in tutti e tre i canali della scarpa.

**Trefack-spännsko**

är stapelbar. Förlängningsplatta med spännvred kan appliceras i alla tre styrningar.

# LENZKES

## Universal Clamping Tools

Tecnica di Fissaggio Universale • Universell Spänntechnik

**6/7**

Series MQ 60  
Clamping pressure to 80 kN  
Serie MQ 60  
Forza di Fissaggio fino a 80 kN  
serie MQ 60  
Spännkraft upp till 80 kN

**22/23**

Side Clamps  
SK 10  
Ganascia  
SK 10  
Spännback  
SK 10

**28**

Extension  
T nut 9°  
Tassello di  
Montaggio  
per Cava T 9°  
Mutter für  
djupt T-spår 9°  
DIN 509

# Contents Indice del programma Innehåll

**Page  
Pagina  
Sida**

**8/9**

Series MQ 70  
Clamping pressure to 50 kN  
Serie MQ 70  
Forza di Fissaggio fino a 50 kN  
serie MQ 70  
Spännkraft upp till 50 kN

**22/23**

Side Clamps  
SKQ 10  
Ganascia  
SKQ 10  
Spännback  
SKQ 10

**29**

T nuts  
high form  
Tassello  
per Cava T, alto  
Mutter für  
T-spår, hög  
DIN 505

**10/11**

Series MQ 100  
Clamping pressure to 50 kN  
Serie MQ 100  
Forza di Fissaggio fino a 50 kN  
serie MQ 100  
Spännkraft upp till 50 kN

**24**

T slot bolts  
Bullone  
per Cava T  
Skruv för  
T-spår  
  
DIN 787

**29**

V nuts  
Tassello  
per Cava V  
Mutter  
für V-spår  
DIN 506, 507, 500

**31**

Combination  
wrench  
Chiave ad Anello  
U-ring Nyckel  
No. 620

**12/13**

Series MQ 110  
Clamping pressure to 35 kN  
Serie MQ 110  
Forza di Fissaggio fino a 35 kN  
serie MQ 110  
Spännkraft upp till 35 kN

**25**

Stud bolts  
Prigioniero  
Tirante  
Stiftskruv  
DIN 6379

**30**

Collar nuts  
Dado Esagonale  
Sexkantmutter  
DIN 6330 B

**32**

Semihead  
head screws  
Vite  
a Testa Piana  
Skruv med  
försänkt skalle  
No. 390

**14/15**

Series MQ 130  
Clamping pressure to 30 kN  
Serie MQ 130  
Forza di Fissaggio fino a 30 kN  
serie MQ 130  
Spännkraft upp till 30 kN

**25**

Stud bolts  
with ISK  
Prigioniero  
Tirante con  
Incavo Esagonale  
Stiftskruv  
med ISK  
No. 380

**30**

Collar nuts  
Dado Esagonale  
con Rondella  
Sexkantmutter  
med fläns  
DIN 6331

**32**

Hexagon  
head screws  
Vite Esagonale  
Sexkantskruv  
No. 385

**16/17**

Series S10 - S20  
Clamping pressure to 70 kN  
Serie S10 - S20  
Forza di Fissaggio fino a 70 kN  
serie S10 - S20  
Spännkraft upp till 70 kN

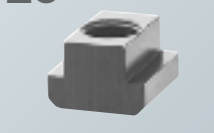
**26**

T nuts  
Dado  
per Cava T  
Mutter  
für T-spår  
DIN 508

**30**

Extension nuts  
Dado di  
Prolungamento  
Förlängnings-  
mutter  
DIN 6334

**32**

Ball pressure  
screws  
Tirante con sfera  
Tryckskruv  
No. 310

**18/19**

Series S30 - S40  
Clamping pressure to 60 kN  
Serie S30 - S40  
Forza di Fissaggio fino a 60 kN  
serie S30 - S40  
Spännkraft upp till 60 kN

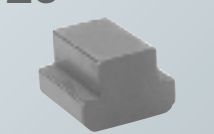
**26**

T nuts blank  
Dado per Cava T  
non Lavorato  
Mutter für T-spår  
änne  
DIN 508

**30**

T bolt set  
Assortimento  
di Fissaggio  
Spännkruvsats  
No. 391

**33**

Work-piece  
protection plate  
Piastrina di  
Protezione  
Tryckbricka  
No. 991

**20**

Extension Blocks  
B 50  
Distanziale  
B 50  
Förhöjningsblock  
B 50

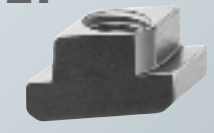
**27**

Rhombus  
T nuts  
Dado per Cava T  
rombo  
Mutter für T-spår  
rombisk  
DIN 508 R

**31**

Spherical seat  
washers  
Rondella a Sfera  
Kulbricka  
DIN 6319 C

**33**

Hexagonal  
allen key  
Chiave Esagonale  
Insexnyckel  
No. 610, 611

**21**

Side clamps  
NU 10  
Fissatore Laterale  
NU 10  
Lågspännare  
NU 10

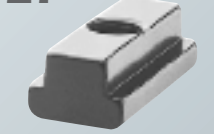
**27**

T nuts  
long  
Dado per Cava T  
Lungo  
Mutter für T-spår  
Lång  
DIN 508 L

**31**

Dished washers  
Rondella  
Articolata  
Konvexbricka  
DIN 6319 D, G

**33**

Torque wrench  
Chiave  
Dinamometrica  
Momentnyckel  
No. 605, 606

**21**

Side clamps  
FL 10  
Fissatore Laterale  
FL 10  
Lågspännare  
FL 10

**28**

Double nuts  
Dado per  
Due Cava T  
Mutter für T-spår  
  
DIN 502

**31**

Flat washers  
Rondella  
Bricka  
DIN 6340

We reserve the rights to make technical changes.  
Prezzi senza IVA – Possibili rettifiche tecniche.  
Priser ges på begäran – Rätt till ändringar förbehålles.

# Multi-Quick MQ 60 complete completo komplett

Clamping pressure to  
Forza di fissaggio fino a  
Spännkraft upp till  
80 kN

Patented.  
Stepless adjustment.  
Strong clamping pressure  
for small clamping torque.

Brevettata.  
Fissaggio di continuo.  
Molta forza di fissaggio  
con poca forza di chiusura.

Patenterad.  
Steglöst ställbar.  
Hög spännkraft med  
lågt spännmoment.



**Material: alloy special steel**

**Materiale: lega in acciaio**

**Material: höglegerat stål**

Item no. 062- ... - ... for tapped holes.

Art.-No. 062- ... - ... per foro filettato.

Art.-Nr. 062- ... - ... för gängat hål.

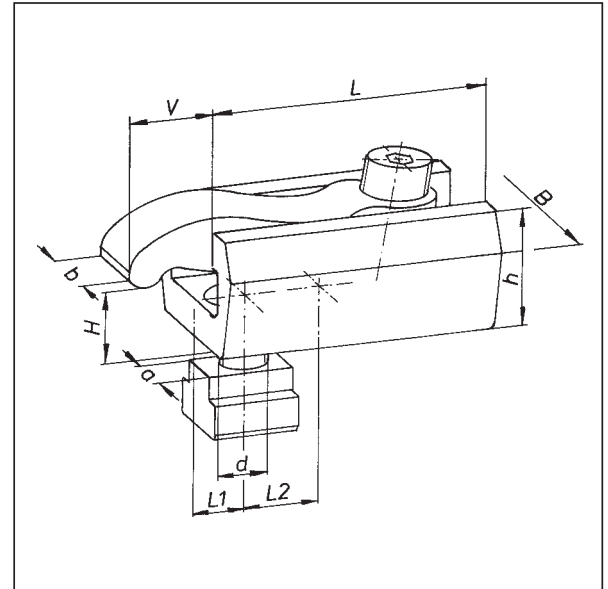

H	d	 a	V	L	L1	L2	B	b	h	kN	Item no. Art.-No. Art.-Nr.	£
5-26	M10	12	26	75	12	20	52	24	37	40	060-026-1012	
	M12	14									060-026-1214	
22-45	M10	12									060-045-1012	
	M12	14									060-045-1214	
5-40	M10	12	50	115	12	28	52	24	37	40	060-040-1012	
	M12	14									060-040-1214	
35-67	M10	12									060-067-1012	
	M12	14									060-067-1214	
5-30	M14	16	30	85	15	25	60	28	42	55	060-030-1416	
	M16	18									060-030-1618	
25-48	M14	16									060-048-1416	
	M16	18									060-048-1618	
5-46	M14	16	58	130	15	32	60	28	42	55	060-046-1416	
	M16	18									060-046-1618	
40-75	M14	16									060-075-1416	
	M16	18									060-075-1618	
5-35	M18	20	32	100	19	32	75	34	48	65	060-035-1820	
	M20	22									060-035-2022	
28-55	M18	20									060-055-1820	
	M20	22									060-055-2022	
5-51	M18	20	65	150	19	38	75	34	48	65	060-051-1820	
	M20	22									060-051-2022	
45-85	M18	20									060-085-1820	
	M20	22									060-085-2022	
10-46	M22	24	48	125	22	38	88	42	57	80	060-046-2224	
	M24	28									060-046-2428	
	M30	36									48	
10-62	M22	24	80	180	22	45	88	42	57	80	060-062-2224	
	M24	28									060-062-2428	
	M30	36									80	

# Multi-Quick MQ 60

spare parts pezzi singoli  
tillbehör



## Universal Clamping Tools

Tecnica di Fissaggio Universale • Universell Spännteknik

Clamping shoe Scarpa di fissaggio Spännsko	Clamping arm Leva di fissaggio Spännarm	Fixing set Assortimento viti Spännsats	Ball pressure screw Tirante a sfera Tryckskruv	 Allen key  Chiave  Nyckel
				

Item no. Art.-No. Art.-Nr.	£	Item no. Art.-No. Art.-Nr.	H	£	Item no. Art.-No. Art.-Nr.	£	Item no. Art.-No. Art.-Nr.	£	Item no. Art.-No. Art.-Nr.	£
060-2-075-1012		060-3-026-12	5-26		960-1012-29		310-16-050		610-08	
060-2-075-1214					960-1214-31					
060-2-075-1012		060-3-045-12	22-45		960-1012-29					
060-2-075-1214					960-1214-31					
060-2-115-1012		060-3-040-12	5-40		960-1012-29		310-16-055			
060-2-115-1214					960-1214-31					
060-2-115-1012		060-3-067-12	35-67		960-1012-29					
060-2-115-1214					960-1214-31					
060-2-085-1416		060-3-030-16	5-30		960-1416-35		310-20-055		610-10	
060-2-085-1618					960-1618-40					
060-2-085-1416		060-3-048-16	25-48		960-1416-35					
060-2-085-1618					960-1618-40					
060-2-130-1416		060-3-046-16	5-46		960-1416-35		310-20-060			
060-2-130-1618					960-1618-40					
060-2-130-1416		060-3-075-16	40-75		960-1416-35					
060-2-130-1618					960-1618-40					
060-2-100-1820		060-3-035-20	5-35		960-1820-45		310-24-060		610-12	
060-2-100-2022					960-2022-51					
060-2-100-1820		060-3-055-20	28-55		960-1820-45					
060-2-100-2022					960-2022-51					
060-2-150-1820		060-3-051-20	5-51		960-1820-45		310-24-070			
060-2-150-2022					960-2022-51					
060-2-150-1820		060-3-085-20	45-85		960-1820-45					
060-2-150-2022					960-2022-51					
060-2-125-2224		060-3-046-24	10-46		960-2224-58		310-24-070		610-12	
060-2-125-2428					960-2428-60					
060-2-125-3036					960-3036-75					
060-2-180-2224		060-3-062-24	10-62		960-2224-58		310-24-080			
060-2-180-2428					960-2428-60					
060-2-180-3036					960-3036-75					

# Multi-Quick MQ 70 complete completo komplett

Clamping pressure to  
Forza di fissaggio fino a  
Spännkraft upp till  
**50 kN**

Patented.  
Stepless adjustment.

Brevettata.  
Fissaggio di continuo.

Patenterad.  
Steglös justering.



**Material: alloy special steel**  
**Materiale: lega in acciaio**  
**Material: höglegerat stål**

Item no. 072- ... - ... for tapped holes.  
Art.-No. 072- ... - ... per foro filettato.  
Art.-Nr. 072- ... - ... för gängat hål.

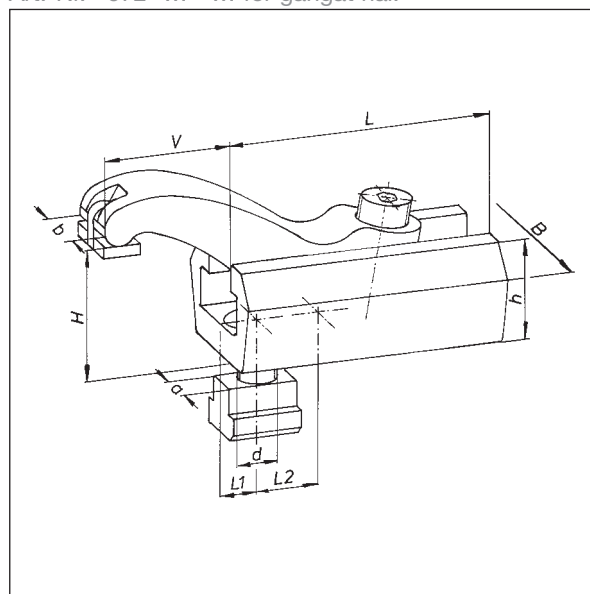

H	d	 a	V	L	L1	L2	B	b	h	kN	Item no. Art.-No. Art.-Nr.	£
5-50	M10	12	62	95	12	-	52	24	37	20	070-050-1012	
	M12	14									070-050-1214	
5-70	M10	12	90	135	12	24	52	24	37	20	070-070-1012	
	M12	14									070-070-1214	
5-60	M14	16	72	110	15	-	60	28	42	30	070-060-1416	
	M16	18									070-060-1618	
5-80	M14	16	105	155	15	28	60	28	42	30	070-080-1416	
	M16	18									070-080-1618	
5-70	M18	20	85	125	19	-	75	34	48	40	070-070-1820	
	M20	22									070-070-2022	
5-90	M18	20	110	175	19	34	75	34	48	40	070-090-1820	
	M20	22									070-090-2022	
5-85	M22	24	100	150	22	-	88	42	57	50	070-085-2224	
	M24	28									070-085-2428	
	M30	36									100	
5-105	M22	24	135	205	22	38	88	42	57	50	070-105-2224	
	M24	28									070-105-2428	
	M30	36									135	







# Multi-Quick MQ 70

spare parts pezzi singoli  
tillbehör



## Universal Clamping Tools

Tecnica di Fissaggio Universale • Universell Spänteknik

Clamping shoe Scarpa di fissaggio Spännsko	Clamping arm Leva di fissaggio Spännarm	Fixing set Assortimento viti Spännsats	Protection plate Piastrina di protezione Spännskyddsklack	Ball pressure screw Tirante a sfera Tryckskruv	<ul style="list-style-type: none"> <li>⬡ Allen key</li> <li>⬡ Chiave</li> <li>⬡ Nyckel</li> </ul>
					

Item no. Art.-No. Art.-Nr.	£	Item no. Art.-No. Art.-Nr.	H	£	Item no. Art.-No. Art.-Nr.	£	Item no. Art.-No. Art.-Nr.	£	Item no. Art.-No. Art.-Nr.	£	Item no. Art.-No. Art.-Nr.	£
070-2-095-1012		070-3-050-12	5-50		960-1012-29		991-7012-1		310-16-050		610-08	
070-2-095-1214								960-1214-31				
070-2-135-1012		070-3-070-12	5-70		960-1012-29		991-7016-1		310-16-055		610-10	
070-2-135-1214								960-1214-31				
070-2-110-1416		070-3-060-16	5-60		960-1416-35		991-7020-1		310-20-055		610-12	
070-2-110-1618								960-1618-40				
070-2-155-1416		070-3-080-16	5-80		960-1416-35		991-7024-1		310-20-060		610-12	
070-2-155-1618								960-1618-40				
070-2-125-1820		070-3-070-20	5-70		960-1820-45		991-7024-1		310-24-070		610-12	
070-2-125-2022								960-2022-51				
070-2-175-1820		070-3-090-20	5-90		960-1820-45		991-7024-1		310-24-080		610-12	
070-2-175-2022								960-2022-51				
070-2-150-2224		070-3-085-24	5-85		960-2224-58		991-7024-1		310-24-080		610-12	
070-2-150-2428								960-2428-60				
070-2-150-3036								960-3036-75				
070-2-205-2224		070-3-105-24	5-105		960-2224-58		991-7024-1		310-24-090		610-12	
070-2-205-2428								960-2428-60				
070-2-205-3036								960-3036-75				

# Multi-Quick MQ 100 complete completo komplett

Clamping pressure to  
Forza di fissaggio fino a  
Spännkraft upp till  
**50 kN**

Patented.  
Strong clamping pressure for  
small clamping torque.  
Highly adjustable through  
integrated sliding plate.

Brevettata.  
Molta forza di fissaggio  
con poca forza di chiusura.  
Maggiore regolazione tramite  
una piastra integrata.

Patenterad.  
Hög spännkraft med  
lågt spännmoment.  
Stor ställbarhet med  
integrerad förlängningsplatta.



**Material: alloy special steel**  
**Materiale: lega in acciaio**  
**Material: höglegerat stål**

Item no. 102- ... - ... for tapped holes.  
Art.-No. 102- ... - ... per foro filettato.  
Art.-Nr. 102- ... - ... för gängat hål.

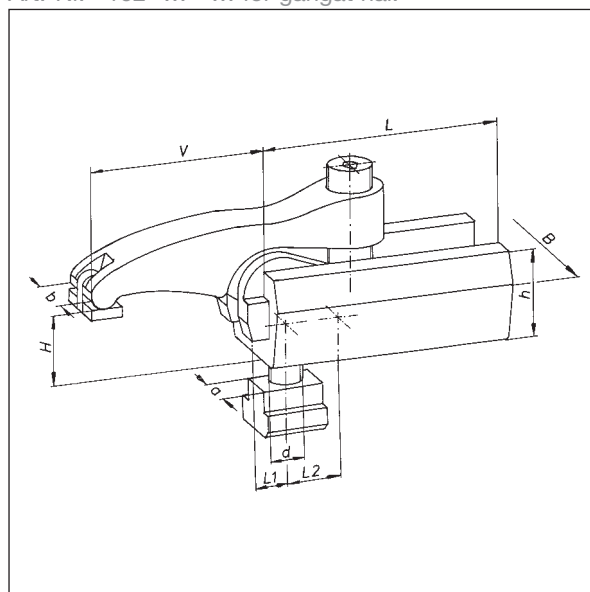

H	d		V	L	L1	L2	B	b	h	kN	Item no. Art.-No. Art.-Nr.	£
3-47	M10	12	75	95	12	20	52	24	37	25	100-047-1012	
	M12	14									100-047-1214	
3-66	M10	12	110	135	12	28	52	24	37	25	100-066-1012	
	M12	14									100-066-1214	
5-57	M14	16	90	110	15	25	60	28	42	35	100-057-1416	
	M16	18									100-057-1618	
5-76	M14	16	130	155	15	32	60	28	42	35	100-076-1416	
	M16	18									100-076-1618	
5-67	M18	20	105	125	19	32	75	34	48	40	100-067-1820	
	M20	22									100-067-2022	
5-86	M18	20	145	175	19	38	75	34	48	40	100-086-1820	
	M20	22									100-086-2022	
8-77	M22	24	120	150	22	38	88	42	57	50	100-077-2224	
	M24	28									100-077-2428	
	M30	36									120	
8-100	M22	24	160	205	22	45	88	42	57	50	100-100-2224	
	M24	28									100-100-2428	
	M30	36									160	







# Multi-Quick MQ 100

spare parts pezzi singoli  
tillbehör



## Universal Clamping Tools

Tecnica di Fissaggio Universale • Universell Spänteknik

Clamping shoe Scarpa di fissaggio Spännsko	Clamping arm with sliding plate Leva di fissaggio con piastra Spännarm med förlängningsplatta	Fixing set Assortimento viti Spännsats	Protection plate Piastrina di protezione Spännskyddsklack	Ball pressure screw Tirante a sfera Tryckskruv	 Allen key  Chiave  Nyckel
					

Item no. Art.-No. Art.-Nr.	£	Item no. Art.-No. Art.-Nr.	H	£	Item no. Art.-No. Art.-Nr.	£	Item no. Art.-No. Art.-Nr.	£	Item no. Art.-No. Art.-Nr.	£	Item no. Art.-No. Art.-Nr.	£
100-2-095-1012		100-5-047-12	3-47		960-1012-29		991-7012-1		310-16-050		610-08	
100-2-095-1214				960-1214-31								
100-2-135-1012		100-5-066-12	3-66		960-1012-29				310-16-055			
100-2-135-1214				960-1214-31								
100-2-110-1416		100-5-057-16	5-57		960-1416-35		991-7016-1		310-20-055		610-10	
100-2-110-1618				960-1618-40								
100-2-155-1416		100-5-076-16	5-76		960-1416-35				310-20-060			
100-2-155-1618				960-1618-40								
100-2-125-1820		100-5-067-20	5-67		960-1820-45		991-7020-1		310-24-070		610-12	
100-2-125-2022				960-2022-51								
100-2-175-1820		100-5-086-20	5-86		960-1820-45				310-24-080			
100-2-175-2022				960-2022-51								
100-2-150-2224		100-5-077-24	8-77		960-2224-58		991-7024-1		310-24-070		610-12	
100-2-150-2428				960-2428-60								
100-2-150-3036				960-3036-75								
100-2-205-2224		100-5-100-24	8-100		960-2224-58				310-24-080			
100-2-205-2428				960-2428-60								
100-2-205-3036				960-3036-75								

# Multi-Quick MQ 110 complete completo komplett

Clamping pressure to  
Forza di fissaggio fino a  
Spännkraft upp till  
**35 kN**

Patented.  
Highly adjustable through  
stackable clamping shoe  
and clamping arm with  
integrated sliding plate.

Brevettata.  
Molta regolabilità tramite  
scarpa di fissaggio  
sovrapponibile e leva  
con piastra integrata.

Patenterad.  
Stor flexibilitet genom  
stapelbara spännblock,  
och spännarm med  
integrerad förlängningsplatta.



**Material:** alloy special steel  
**Clamping shoe:** special alloyed aluminium  
**Materiale:** lega in acciaio  
**Scarpa di fissaggio:** lega speciale di alluminio  
**Material:** höglegerat stål  
**Spännsko:** speciallegering av aluminium  
Item no. 112- ... - ... for tapped holes.  
Art.-No. 112- ... - ... per foro filettato.  
Art.-Nr. 112- ... - ... för gängat hål.

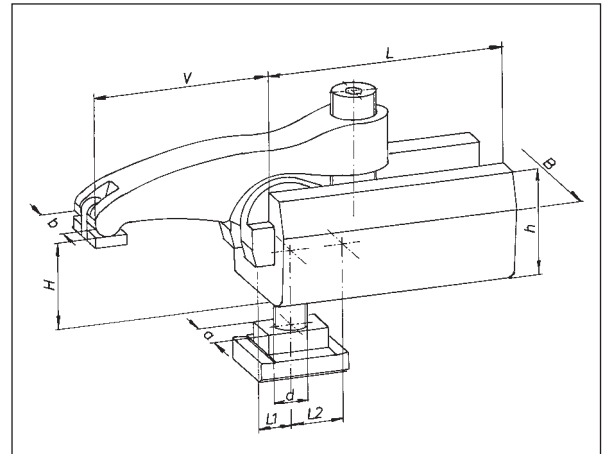

H	d	 a	V	L	L1	L2	B	b	h	kN	Item no. Art.-No. Art.-Nr.	£
8-52	M10	12	75	95	12	20	54	24	44	20	110-052-1012	
	M12	14									110-052-1214	
8-71	M10	12	110	135	12	28	54	24	44	20	110-071-1012	
	M12	14									110-071-1214	
10-62	M14	16	90	110	15	25	64	28	50	30	110-062-1416	
	M16	18									110-062-1618	
10-81	M14	16	130	155	15	32	64	28	50	30	110-081-1416	
	M16	18									110-081-1618	
10-72	M18	20	105	125	19	32	80	34	55	35	110-072-1820	
	M20	22									110-072-2022	
	M20	28									110-072-2028	
10-91	M18	20	145	175	19	38	80	34	55	35	110-091-1820	
	M20	22									110-091-2022	
	M20	28									110-091-2028	

# Multi-Quick MQ 110

spare parts pezzi singoli  
tillbehör



## Universal Clamping Tools

Tecnica di Fissaggio Universale • Universell Spänteknik

Clamping shoe Scarpa di fissaggio Spännsko	Clamping arm with sliding plate Leva di fissaggio con piastra Spännarm med förlängningsplatta	Fixing set Assortimento viti Spännsats	Protection plate Piastrina di protezione Spännskyddsklack	Ball pressure screw Tirante a sfera Tryckskruv	<ul style="list-style-type: none"> <li>⬡ Allen key</li> <li>⬡ Chiave</li> <li>⬡ Nyckel</li> </ul>
					

Item no. Art.-No. Art.-Nr.	£	Item no. Art.-No. Art.-Nr.	H	£	Item no. Art.-No. Art.-Nr.	£	Item no. Art.-No. Art.-Nr.	£	Item no. Art.-No. Art.-Nr.	£	Item no. Art.-No. Art.-Nr.	£
110-2-095-1012		130-5-052-12	8-52		969-1012-35		991-7012-1		310-16-050		610-08	
110-2-095-1214				969-1214-35								
110-2-135-1012		130-5-071-12	8-71		969-1012-35				310-16-055			
110-2-135-1214				969-1214-35								
110-2-110-1416		130-5-062-16	10-62		969-1416-41		991-7016-1		310-20-055		610-10	
110-2-110-1618				969-1618-45								
110-2-155-1416		130-5-081-16	10-81		969-1416-41				310-20-060			
110-2-155-1618				969-1618-45								
110-2-125-1820		130-5-072-20	10-72		969-1820-51		991-7020-1		310-24-070		610-12	
110-2-125-2022				969-2022-51								
110-2-125-2028				969-2028-60								
110-2-175-1820		130-5-091-20	10-91		969-1820-51				310-24-080			
110-2-175-2022				969-2022-51								
110-2-175-2028				969-2028-60								

# Multi-Quick MQ 130 complete completo komplett

Clamping pressure to  
Forza di fissaggio fino a  
Spännkraft upp till  
**30 kN**

Patented.  
High clamping pressure  
and adjustability through  
stackable triple clamping  
shoe and clamping arm  
with integrated sliding plate.

Brevettata.  
Maggiore altezza di fissaggio  
e regolabilità tramite scarpa  
di fissaggio tripla sovrapponibile  
e leva con piastra integrata.

Patenterad.  
Hög spännhöjd och flexibilitet  
genom stapelbara dubbel-  
spännsko och spännarm  
med integrerad förlängningsplatta.



**Material:** alloy special steel  
**Clamping shoe:** special alloyed aluminium  
**Levier:** lega in acciaio  
**Scarpa di fissaggio:** lega speciale di alluminio  
**Material:** höglegerat stål  
**Spännsko:** speciallegering av aluminium  
Item no. 132- ... - ... for tapped holes.  
Art.-No. 132- ... - ... per foro filettato.  
Art.-Nr. 132- ... - ... för gängat hål.

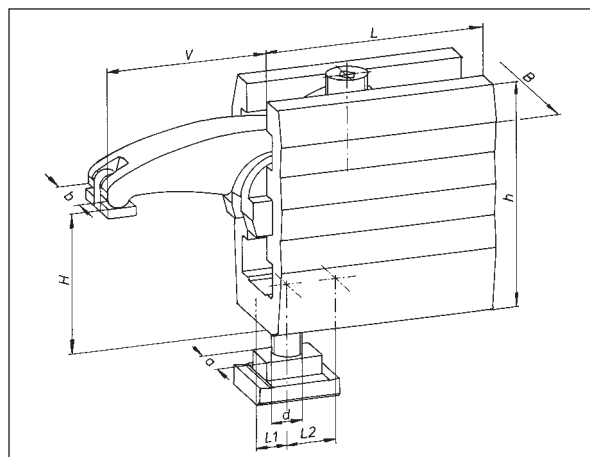

H	d	 a	V	L	L1	L2	B	b	h	kN	Item no. Art.-No. Art.-Nr.	£
8-108	M10	12	75	95	12	20	54	24	100	15	130-108-1012	
	M12	14									130-108-1214	
8-127	M10	12	110	135	12	28	54	24	100	15	130-127-1012	
	M12	14									130-127-1214	
10-126	M14	16	90	110	15	25	64	28	114	25	130-126-1416	
	M16	18									130-126-1618	
10-145	M14	16	130	155	15	32	64	28	114	25	130-145-1416	
	M16	18									130-145-1618	
10-148	M18	20	105	125	19	32	80	34	134	30	130-148-1820	
	M20	22									130-148-2022	
	M20	28									130-148-2028	
10-167	M18	20	145	175	19	38	80	34	134	30	130-167-1820	
	M20	22									130-167-2022	
	M20	28									130-167-2028	

# Multi-Quick MQ 130

spare parts pezzi singoli  
tillbehör



## Universal Clamping Tools

Tecnica di Fissaggio Universale • Universell Spänteknik

Clamping shoe Scarpa di fissaggio Spännsko	Clamping arm with sliding plate Leva di fissaggio con piastra Spännarm med förlängningsplatta	Fixing set Assortimento viti Spännsats	Protection plate Piastrina di protezione Spännskyddsklack	Ball pressure screw Tirante a sfera Tryckskruv	<ul style="list-style-type: none"> <li>⬡ Allen key</li> <li>⬡ Chiave</li> <li>⬡ Nyckel</li> </ul>
					

Item no. Art.-No. Art.-Nr.	£	Item no. Art.-No. Art.-Nr.	H	£	Item no. Art.-No. Art.-Nr.	£	Item no. Art.-No. Art.-Nr.	£	Item no. Art.-No. Art.-Nr.	£	Item no. Art.-No. Art.-Nr.	£
130-2-095-1012		130-5-052-12	8-52		969-1012-35		991-7012-1		310-16-050		610-08	
130-2-095-1214				969-1214-35								
130-2-135-1012		130-5-071-12	8-71		969-1012-35				310-16-055			
130-2-135-1214				969-1214-35								
130-2-110-1416		130-5-062-16	10-62		969-1416-41		991-7016-1		310-20-055		610-10	
130-2-110-1618				969-1618-45								
130-2-155-1416		130-5-081-16	10-81		969-1416-41				310-20-060			
130-2-155-1618				969-1618-45								
130-2-125-1820		130-5-072-20	10-72		969-1820-51		991-7020-1		310-24-070		610-12	
130-2-125-2022				969-2022-51								
130-2-125-2028				969-2028-60								
130-2-175-1820		130-5-091-20	10-91		969-1820-51				310-24-080			
130-2-175-2022				969-2022-51								
130-2-175-2028				969-2028-60								

# Clamping frame

Elemento di fissaggio ad arco  
Spännbygel

# S10-S20 complete completo komplett

Clamping pressure to  
Forza di fissaggio fino a  
Spännkraft upp till  
70 kN

Vertically stepless adjustable.  
020 is used where protruding  
bolts are obstructive.

Fissaggio verticale continuo  
020 viene usata la dove nel  
fissare il tirante sporgente può  
dare fastidio.

Vertikalt steglöst ställbar.  
020 ändamål, i lägen där  
förlänga skruvar är i vägen.



**Material:** hardened steel  
**Materiale:** acciaio bonificato  
**Material:** Kvalitetsstål

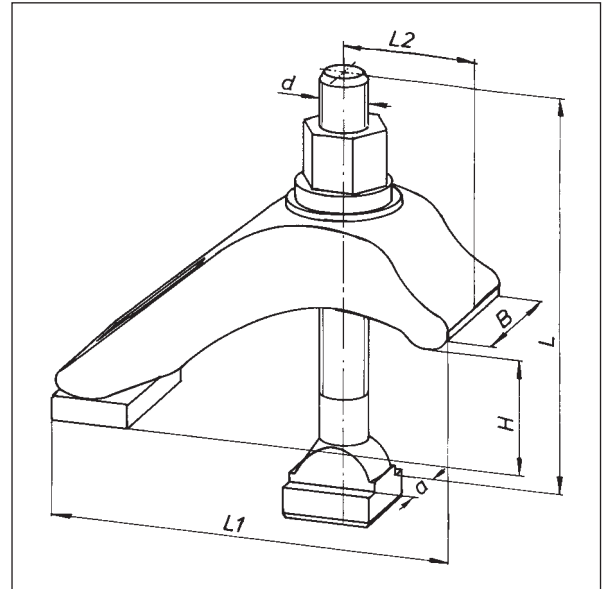

H	d	a	L1	L2	B	kN	Item no. Art.-No. Art.-Nr.	£	Item no. Art.-No. Art.-Nr.	£
0-45	M10	12	93	28-44	46	18	010-045-1012		020-045-1012	
	M12	14					010-045-1214		020-045-1214	
	M14	16	93	28-44	46	30	010-045-1416		020-045-1416	
	M16	18					010-045-1618		020-045-1618	
	M16	20					010-045-1620		020-045-1620	
	M16	22					010-045-1622		020-045-1622	
10-70	M10	12	125	34-53	46	20	010-070-1012		020-070-1012	
	M12	14					010-070-1214		020-070-1214	
	M14	16	125	34-53	46	32	010-070-1416		020-070-1416	
	M16	18					010-070-1618		020-070-1618	
	M18	20	125	34-55	52	45	010-070-1820		020-070-1820	
	M20	22					010-070-2022		020-070-2022	
	M20	24					010-070-2024		020-070-2024	
	M20	28					010-070-2028		020-070-2028	
30-110	M10	12	160	35-60	52	22	010-110-1012		020-110-1012	
	M12	14					010-110-1214		020-110-1214	
	M14	16	160	35-60	52	35	010-110-1416		020-110-1416	
	M16	18					010-110-1618		020-110-1618	
	M18	20					010-110-1820		020-110-1820	
	M20	22					010-110-2022		020-110-2022	
	M22	24		35-62	60	60	010-110-2224		020-110-2224	
	M24	28					010-110-2428		020-110-2428	
90-180	M12	14	200	40-65	60	25	010-180-1214		020-180-1214	
	M14	16					010-180-1416		020-180-1416	
	M16	18	200	40-65	60	40	010-180-1618		020-180-1618	
	M18	20					010-180-1820		020-180-1820	
	M20	22					010-180-2022		020-180-2022	
	M22	24					010-180-2224		020-180-2224	
	M24	28	200	40-65	60	70	010-180-2428		020-180-2428	

# Clamping frame S10 - S20

Elemento di fissaggio ad arco  
Spännbygel





spare parts

pezzi singoli  
tillbehör

# LENZKE

## Universal Clamping Tools

Tecnica di Fissaggio Universale • Universell Spänteknik

Clamping frame Arco di fissaggio Spännbygel	Fixing set Assortimento bulloni di fissaggio Spännsats	Fixing set Assortimento bulloni di fissaggio Spännsats	Spherical seat washer Rondella a sfera Kulformad bricka	Combination wrench Chiave Nyckel
	010 	020 		

Item no. Art.-No. Art.-Nr.	£	Item no. Art.-No. Art.-Nr.	L	£	Item no. Art.-No. Art.-Nr.	L	£	Item no. Art.-No. Art.-Nr.	£	Item no. Art.-No. Art.-Nr.	£
010-045-17		910-045-1012	100		920-045-1012	65		019-3510		620-16	
		910-045-1214	112		920-045-1214			019-3512		620-18	
		910-045-1416			920-045-1416	70		019-3514		620-21	
		910-045-1618	125		920-045-1618	75		019-3516		620-24	
		910-045-1620	160		920-045-1620	80					
		910-045-1622			920-045-1622						
010-070-17		910-070-1012	125		920-070-1012	75		019-3510		620-16	
		910-070-1214			920-070-1214	80		019-3512		620-18	
		910-070-1416	140		920-070-1416	85		019-3514		620-21	
		910-070-1618	150		920-070-1618			019-3516		620-24	
010-070-21		910-070-1820	160		920-070-1820	95		019-4018		620-27	
		910-070-2022			920-070-2022			019-4020		620-30	
		910-070-2024	180		920-070-2024	105					
		910-070-2028			920-070-2028						
010-110-21		910-110-1012			920-110-1012	100		019-4010		620-16	
		910-110-1214			920-110-1214	105		019-4012		620-18	
		910-110-1416	190		920-110-1416	110		019-4014		620-21	
		910-110-1618	200		920-110-1618			019-4016		620-24	
		910-110-1820			920-110-1820	115		019-4018		620-27	
		910-110-2022			920-110-2022	120		019-4020		620-30	
010-110-25		910-110-2224			920-110-2224	130		019-4522		620-34	
		910-110-2428			920-110-2428			019-4524		620-36	
010-180-25		910-180-1214	250		920-180-1214	170		019-4512		620-18	
		910-180-1416			920-180-1416	175		019-4514		620-21	
		910-180-1618			920-180-1618			019-4516		620-24	
		910-180-1820	265		920-180-1820	180		019-4518		620-27	
		910-180-2022	280		920-180-2022	185		019-4520		620-30	
		910-180-2224			920-180-2224	190		019-4522		620-34	
		910-180-2428	290		920-180-2428			019-4524		620-36	

# Clamping frame

Elemento di fissaggio ad arco  
Spännbygel

# S30-S40 complete completo komplett

Clamping pressure to  
Forza di fissaggio fino a  
Spännkraft upp till  
60 kN

Vertically stepless adjustable,  
horizontally adjustable in the  
frame.  
040 is used where protruding  
bolts are obstructive.

Fissaggio di continuo in  
verticale, orizzontale regolabile  
nella scanalatura.  
040 usato là dove il bullone  
fuoriuscente può dare fastidio.

Steglös inställbar i horizontal  
och vertikal riktning.  
040 ändamål, i lägen där  
förlånga skruvar är i vägen.

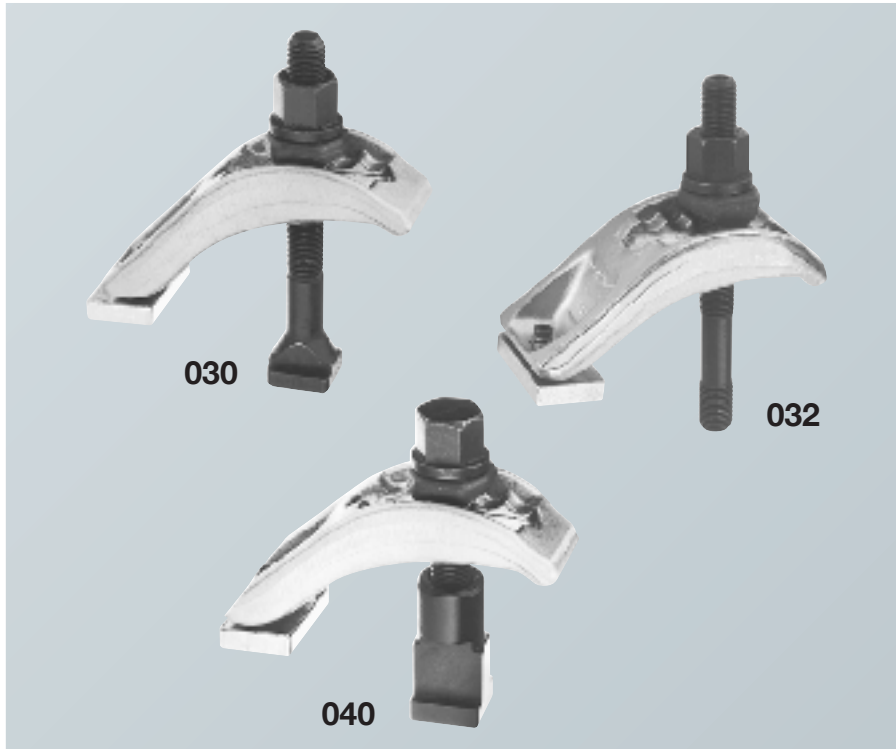

**Material: hardened steel**  
**Materiale: acciaio bonificato**  
**Material: Kvalitetsstål**

Item no. 032- ... - ... for tapped holes.  
Art.-No. 032- ... - ... per foro filettato.  
Art.-Nr. 032- ... - ... för gängat hål.

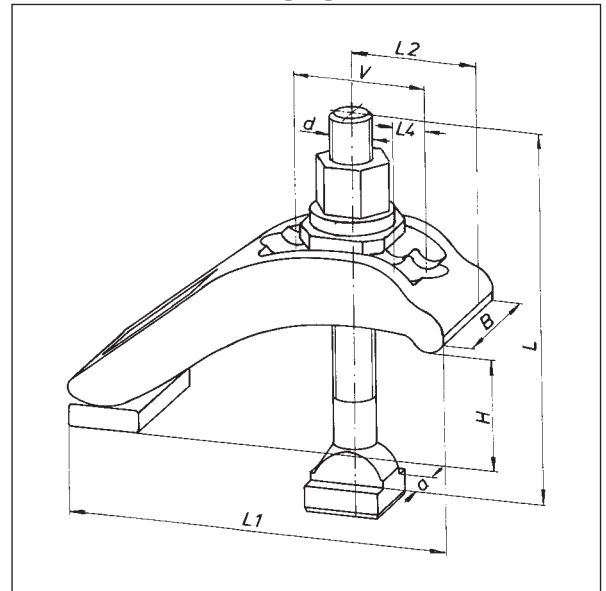

H	d	a	V	L1	L2	L4	B	kN	Item no. Art.-No. Art.-Nr.	£	Item no. Art.-No. Art.-Nr.	£	Item no. Art.-No. Item no.	£											
0-45	M10	12	36	110	20-56	12	46	15	030-045-1012		032-045-10		040-045-1012												
	M12	14							030-045-1214		032-045-12		040-045-1214												
	M14	16	36	110	23-59	12	52	25	030-045-1416		032-045-14		040-045-1416												
	M16	18							030-045-1618		032-045-16		040-045-1618												
	M16	20							030-045-1620		-		040-045-1620												
	M16	22							030-045-1622		-		040-045-1622												
10-70	M10	12	50	135	20-70	13	46	15	030-070-1012		032-070-10		040-070-1012												
	M12	14							030-070-1214		032-070-12		040-070-1214												
	M14	16	50	135	20-70	13	52	25	030-070-1416		032-070-14		040-070-1416												
	M16	18							030-070-1618		032-070-16		040-070-1618												
	M18	20	50	140	25-75	13	60	40	030-070-1820		032-070-18		040-070-1820												
	M20	22							030-070-2022		032-070-20		040-070-2022												
	M20	24							030-070-2024		-		040-070-2024												
	M20	28							030-070-2028		-		040-070-2028												
30-110	M10	12	75	190	20-95	15	52	18	030-110-1012		-		040-110-1012												
	M12	14							030-110-1214		032-110-12		040-110-1214												
	M14	16	75	190	20-95	15	52	30	030-110-1416		032-110-14		040-110-1416												
	M16	18							030-110-1618		032-110-16		040-110-1618												
	M18	20	75	200	25-100	15	60	40	030-110-1820		032-110-18		040-110-1820												
	M20	22							030-110-2022		032-110-20		040-110-2022												
	M22	24	75	200	25-100	15	66	50	030-110-2224		032-110-22		040-110-2224												
	M24	28							030-110-2428		032-110-24		040-110-2428												
90-180	M12	14	90	240	35-125	15	66	20	030-180-1214		-		040-180-1214												
	M14	16							030-180-1416		-		040-180-1416												
	M16	18						90	240	35-125	15	66	35	030-180-1618		032-180-16		040-180-1618							
	M18	20												030-180-1820		032-180-18		040-180-1820							
	M20	22												90	240	35-125	15	66	50	030-180-2022		032-180-20		040-180-2022	
	M22	24																		030-180-2224		032-180-22		040-180-2224	
	M24	28																		030-180-2428		032-180-24		040-180-2428	

# Clamping frame S30 - S40

Elemento di fissaggio ad arco  
Spännbygel







spare parts

pezzi singoli  
tillbehör

# LENZKE

## Universal Clamping Tools

Tecnica di Fissaggio Universale • Universell Spänteknik

Clamping frame Arco di fissaggio Spännbygel	Fixing set Assortimento bulloni di fissaggio Spännsats	Fixing set Assortimento bulloni di fissaggio Spännsats	Fixing set Assortimento bulloni di fissaggio Spännsats	Pressure piece Rondella Tryckbricka	Combination wrench Chiave Nyckel
	030 	032 	040 		

Item no. Art.-No. Art.-Nr.	£	Item no. Art.-No. Art.-Nr.	L	£	Item no. Art.-No. Art.-Nr.	L	£	Item no. Art.-No. Art.-Nr.	L	£	Item no. Art.-No. Art.-Nr.	£	Item no. Art.-No. Art.-Nr.	£					
030-045-13		930-045-1012	100		932-045-10	112		940-045-1012	65		039-2810		620-16						
		930-045-1214	112					932-045-12		940-045-1214			65		039-2812		620-18		
030-045-17		930-045-1416			932-045-14	125		940-045-1416	70		039-3214		620-21						
		930-045-1618	125					932-045-16		940-045-1618			75		039-3216		620-24		
		930-045-1620	125					-		940-045-1620			80						
		930-045-1622						-		940-045-1622									
030-070-13		930-070-1012	132		932-070-10	140		940-070-1012	75		039-2810		620-16						
		930-070-1214						932-070-12		940-070-1214			80		039-2812		620-18		
030-070-17		930-070-1416	140		932-070-14	150		940-070-1416	85		039-3214		620-21						
		930-070-1618	150					932-070-16	160	940-070-1618					039-3216		620-24		
030-070-21		930-070-1820	160		932-070-18			940-070-1820	95		039-4018		620-27						
		930-070-2022						932-070-20		940-070-2022					039-4020		620-30		
		930-070-2024	180					-		940-070-2024			105						
		930-070-2028						-		940-070-2028									
030-110-17		930-110-1012			932-110-12	200		940-110-1012	100		039-3210		620-16						
		930-110-1214						932-110-14		940-110-1214			105		039-3212		620-18		
		930-110-1416	190					932-110-16		940-110-1416			110		039-3214		620-21		
		930-110-1618	200							940-110-1618					039-3216		620-24		
030-110-21		930-110-1820			932-110-18	212		940-110-1820	115		039-4018		620-27						
		930-110-2022	212					932-110-20	224	940-110-2022			120		039-4020		620-30		
030-110-25		930-110-2224	224		932-110-22			940-110-2224	130		039-4522		620-34						
		930-110-2428						932-110-24	250	940-110-2428					039-4524		620-36		
030-180-25		930-180-1214	250		932-180-16	280		940-180-1214	170		039-4512		620-18						
		930-180-1416						-		940-180-1416			175		039-4514		620-21		
		930-180-1618	265					932-180-18		940-180-1618					039-4516		620-24		
		930-180-1820						932-180-20	300	940-180-1820			180		039-4518		620-27		
		930-180-2022	280					932-180-22	315	940-180-2022			185		039-4520		620-30		
		930-180-2224								940-180-2224			190		039-4522		620-34		
		930-180-2428	290					932-180-24		940-180-2428					039-4524		620-36		

# Extension block **B50 complete** completo komplett

Clamping pressure to  
Forza di fissaggio fino a  
Spännkraft upp till  
**50 kN**

Ideal accessory for our  
clamping elements.  
Also available in  
special lengths.

Combinazione ideale con i  
nostri elementi di fissaggio.  
Disponibili anche in  
lunghezze particolari

Idealiskt komplement  
till våra spännelement.  
Levereras i olika storlekar.



**Material: special alloy aluminium**  
**Materiale: lega speciale di alluminio**  
**Material: speciallegering av aluminium**

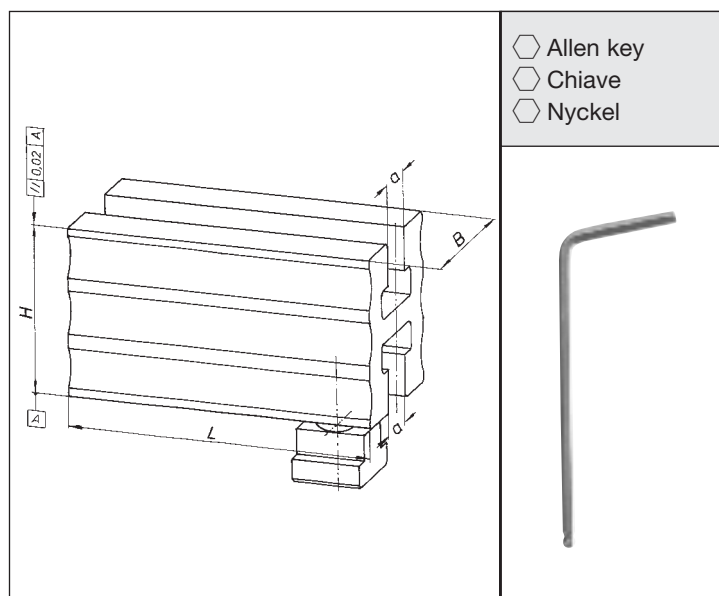

H	d		B	kN	Item no. Art.-No. Art.-Nr.	L	£	Item no. Art.-No. Art.-Nr.	L	£	Item no. Art.-No. Art.-Nr.	£
50	M10	12	40	15	050-050-1012	125		051-050-1012	80		610-06	
110					050-110-1012			051-110-1012				
55	M12	14	45	20	050-055-1214			051-055-1214			610-08	
120					050-120-1214			051-120-1214				
65	M14	16	55	25	050-065-1416			051-065-1416			610-10	
125					050-125-1416			051-125-1416				
70	M16	18	60	30	050-070-1618			051-070-1618			610-12	
130					050-130-1618			051-130-1618				
85	M18	20	66	35	050-085-1820	180		051-085-1820	100		610-12	
175					050-175-1820			051-175-1820				
90	M20	22	70	40	050-090-2022			051-090-2022			610-12	
180					050-180-2022			051-180-2022				
100	M22	24	84	45	050-100-2224			051-100-2224			610-12	
190					050-190-2224			051-190-2224				
110	M24	28	90	50	050-110-2428			051-110-2428			610-12	
200					050-200-2428			051-200-2428				

# Side clamp NU10, FL10

Fissaggio laterale  
Lågspännare

for free surface work  
Per lavorazione di superfici libere / För fria ytbearbetningar

**complete** completo  
komplett



## Universal Clamping Tools

Tecnica di Fissaggio Universale • Universell Spänteknik

# Clamping tool NU10

Fissatore a tassello / T-spårspännare

For clamping of very flat components. Per fissaggio di pezzi piani. För att spänna fast låga arbetsstycken.

**Material:** alloy special steel, hardened

**Materiale:** lega di acciaio temperato

**Material:** legerat verktygsstål, härdat

- Allen key
- Chiave
- Nyckel

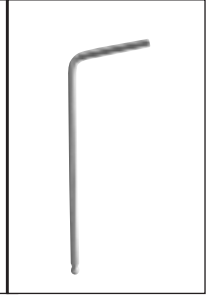
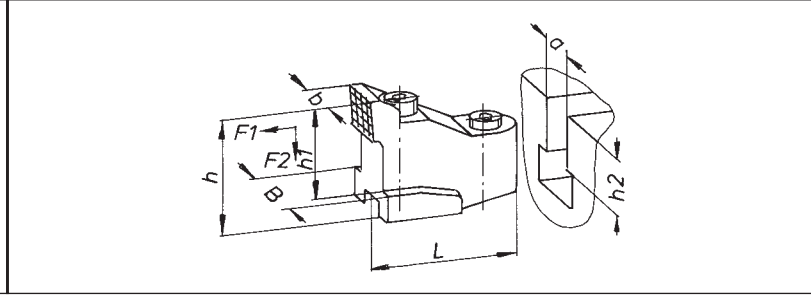

a	b	h	h1	h2	B	L	kN F1	kN F2	Item no. Art.-No. Art.-Nr.	£	Item no. Art.-No. Art.-Nr.	£
12	11,6	27	21	12-17	18	33	6,0	3,0	002-1012		612-04	
14	13,6	31	24	14-19	22	40	7,0	3,5	002-1214		612-05	
16	15,5	35	27	16-22	25	46	8,0	4,0	002-1416		610-06	
18	17,4	39	30	18-24	28	49	10,0	5,0	002-1618		610-06	
22	21,5	50	37	22-30	35	63	16,0	8,0	002-2022		610-08	
28	27,4	62	46	28-36	44	79	18,0	9,0	002-2428		610-10	

# Side clamp FL10

Fissatore piano / Lågspännare

Low construction height. Per pezzi di bassa altezza. Låg spännhöjd

**Material:** alloy special steel, hardened

**Materiale:** lega di acciaio temperato

**Material:** legerat verktygsstål, härdat

- Allen key
- Chiave
- Nyckel

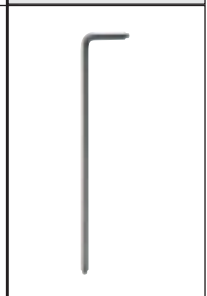
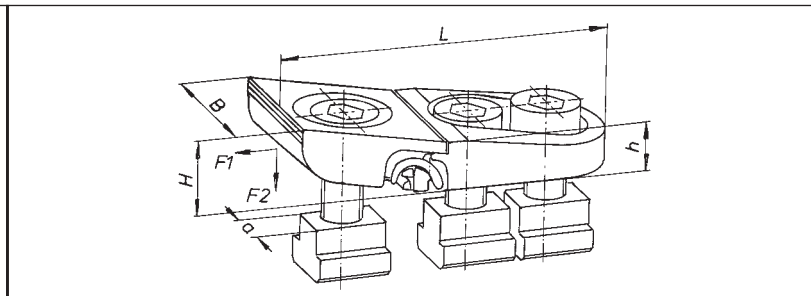

d	a	H	B	L	h	kN F1	kN F2	Item no. Art.-No. Art.-Nr.	£	Item no. Art.-No. Art.-Nr.	£
M10	12	25	44	110	16	15,0	7,5	004-1012		611-08	
M12	14							004-1214		611-10	
M12	16							004-1216			
M14	16	30	56	130	19	20,0	10,0	004-1416		611-12	
M16	18							004-1618		611-14	
M16	20							004-1620			
M18	20	36	62	152	22	30,0	15,0	004-1820			
M20	22							004-2022		611-17	
M20	24							004-2024			
M20	28							004-2028			

# Clamping jaw

Ganascia di fissaggio  
Spännback

# SK10-SKQ10

complete  
completa / komplett

Clamping pressure to  
Forza di fissaggio fino a  
Spännkraft upp till  
**50 kN**

For free  
surface work.

Per lavorazione  
di Superfici libere.

För fria  
ytbearbetningar.

**Material: main body from cast material, replacement face from alloyed steel**

**Materiale: la ganascia è in ghisa sferoidale, il prisma è una lega di acciaio**

**Material: speciallegering, Spännback av legerat stål**

Item no. 006- .. -0 reversable.

Item no. 006- .. -1 with bolted face.

Art.-No. 006- .. -0 con prisma rivoltabile.



Art.-No. 006- .. -1 con ganascia svitabile.

Art.-Nr. 006- .. -0 vändbar.

Art.-Nr. 006- .. -1 ändringsbar.

SK10 may be used sideways in the T slot.

SK10 utilizzabile longilineo la scanalatura T. SK10 ställbar längsmed T-spår.

-  Allen key
-  Chiave
-  Nyckel

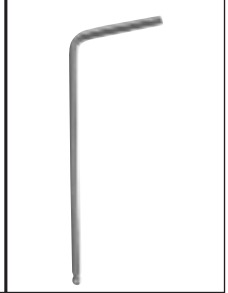
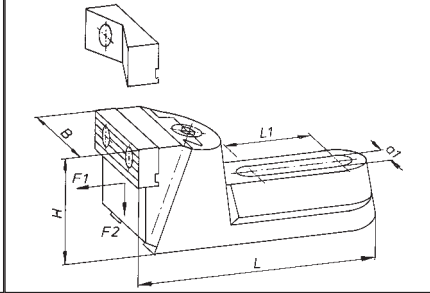
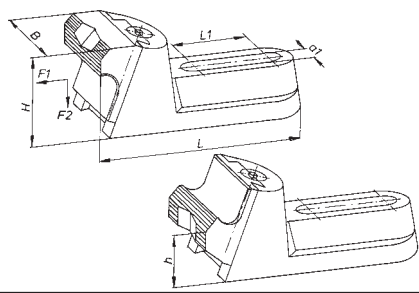

H	h	a1	B	L	L1	kN F1	kN F2	Item no. Art.-No. Art.-Nr.	£	Item no. Art.-No. Art.-Nr.	£
35-46	11-22	13	51	110	35	16	8	006-13-0		610-08	
	-							006-13-1			
48-63	16-31	17	62	132	45	20	10	006-17-0		610-12	
	-							006-17-1			
70-100	21-51	21	80	180	65	30	15	006-21-0		610-14	
	-							006-21-1			
105-150	26-71	25	102	245	85	50	25	006-25-0		612-17	
	-							006-25-1			

Item no. 008- .. -0 reversable.

Item no. 008- .. -1 with bolted face.



Art.-No. 008- .. -0 con prisma rivoltabile.

Art.-No. 008- .. -1 con ganascia svitabile.

Art.-Nr. 008- .. -0 vändbar.

Art.-Nr. 008- .. -1 utbytbar.

SKQ10 may be used sideways and at any angle to the T slot. SKQ10 utilizzabile longilineo e obliquo alla scanalatura T. SKQ10 längsled och i vinkel mot T-spår monterbar.

-  Allen key
-  Chiave
-  Nyckel

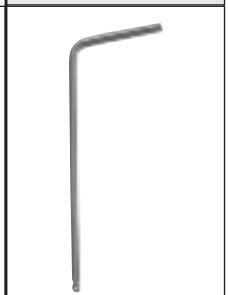
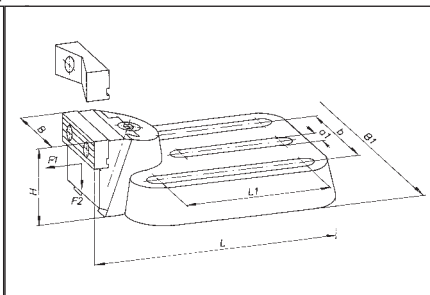
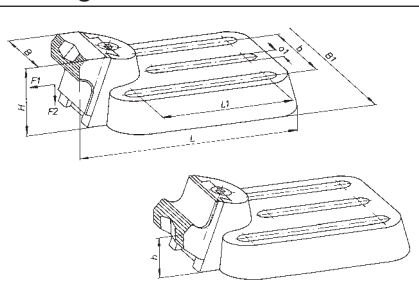

H	h	a1	B	B1	b	L	L1	kN F1	kN F2	Item no. Art.-No. Art.-Nr.	£	Item no. Art.-No. Art.-Nr.	£
35-46	11-22	13	51	98	63	140	80	16	8	008-13-0		610-08	
	-									008-13-1			
48-63	16-31	17	62	124	80	165	100	20	10	008-17-0		610-12	
	-									008-17-1			
70-100	21-51	21	80	152	100	210	125	30	15	008-21-0		610-14	
	-									008-21-1			
105-150	26-71	25	102	202	125	285	160	50	25	008-25-0		612-17	
	-									008-25-1			

# Clamping jaw SK10 - SKQ10

## spare parts





pezzi singoli  
tillbehör

Ganascia di fissaggio  
Spännback





# LENZKE

## Universal Clamping Tools

Tecnica di Fissaggio Universale • Universell Spänteknik

Fixings set Assortimento bulloni Spännsats	Fixing set Assortimento bulloni Spännsats	Driving ring Filetto a mandrino Gängspindel	Retaining ring Mezzo anello Medbringarhalvring
			

H	d		Item no. Art.-No. Art.-Nr.	L	£	Item no. Art.-No. Art.-Nr.	L	£	Item no. Art.-No. Art.-Nr.	£	Item no. Art.-No. Art.-Nr.	£
35-46	M12	12	906-13-1212	50		907-13-1012	40		009-13-1		009-13-2	
	M12	14	906-13-1214	50		907-13-1214	45					
	M12	16	906-13-1216	63		907-13-1216	45					
48-63	M12	14	906-17-1214	63		907-17-1214	55		009-17-1		009-17-2	
	M14	16	906-17-1416	80		907-17-1416	55					
	M16	18	906-17-1618	80		907-17-1618	60					
	M16	20	906-17-1620	100		907-17-1620	60					
	M16	22	906-17-1622	100		907-17-1622	60					
70-100	M16	18	906-21-1618	100		907-21-1618	70		009-21-1		009-21-2	
	M18	20	906-21-1820	100		907-21-1820	75					
	M20	22	906-21-2022	100		907-21-2022	80					
	M20	24	906-21-2024	125		907-21-2024	80					
	M20	28	906-21-2028	125		907-21-2028	90					
105-150	M16	18	906-25-1618	125		907-25-1618	95		009-25-1		009-25-2	
	M18	20	906-25-1820	125		907-25-1820	100					
	M20	22	906-25-2022	125		907-25-2022	100					
	M22	24	906-25-2224	125		907-25-2224	110					
	M24	28	906-25-2428	140		907-25-2428	120					
	M24	32	906-25-2432	160		907-25-2432	120					
	M24	36	906-25-2436	160		907-25-2436	120					

Suitable for Utilizzabile per Utbyttbar till	replacement face – steel ceppo in acciaio Insatsback-stål	replacement face – plastic ceppo in plastica Insatsback-plast	concave face – steel ceppo a prisma in acciaio Prismaback-stål	concave face – plastic ceppo a prisma in plastica Prismaback-plast				
Item no. Art.-No. 006--..1 Art.-Nr. 008--..1								
H	Item no. Art.-No. Art.-Nr.	£	Item no. Art.-No. Art.-Nr.	£	Item no. Art.-No. Art.-Nr.	£	Item no. Art.-No. Art.-Nr.	£
35- 46	009-13-31		009-13-32		009-13-33		009-13-34	
48- 63	009-17-31		009-17-32		009-17-33		009-17-34	
70-100	009-21-31		009-21-32		009-21-33		009-21-34	
105-150	009-25-31		009-25-32		009-25-33		009-25-34	

# Standard parts Prodotti di norma Normdelar

Product class A according DIN ISO 4759 part 1  
Hardness class 10.9

Produzione di classe A secondo DIN ISO 4759, parte 1  
Resistenza di classe 10.9

Produktklass A till DIN ISO 4759 Del 1  
Hållfasthetsklass 10.9

## T slot bolts DIN 787

### Vite per cave-T DIN 787

### Skruv för T-spår DIN 787

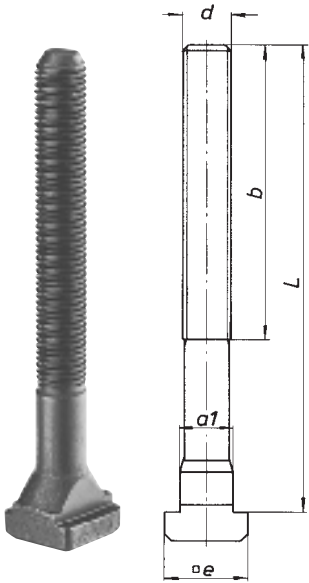

d	a	L	b	a1	e	k	Item no. Art.-No. Art.-Nr.	£
M06	6	25	15	5,7	10	4	787-0606-025	
		40	28				787-0606-040	
		63	40				787-0606-063	
M08	8	32	22	7,7	13	6	787-0808-032	
		50	35				787-0808-050	
		80	50				787-0808-080	
M10	10	40	30	9,7	15		787-1010-040	
		63	45				787-1010-063	
		100	60				787-1010-100	
M12	12	50	35	11,7	18	7	787-1212-050	
		63	40				787-1212-063	
		80	55				787-1212-080	
		100	63				787-1212-100	
		125	75				787-1212-125	
		132	80				787-1212-132	
		180	100				787-1212-180	
		200	120				787-1212-200	
M14	14	50	35	13,7	22	8	787-1214-050	
		63	40				787-1214-063	
		80	55				787-1214-080	
		112	70				787-1214-112	
		125	75				787-1214-125	
		132	80				787-1214-132	
		180	110				787-1214-180	
		200	120				787-1214-200	
M14	16	63	45	15,7	25	9	787-1416-063	
		80	55				787-1416-080	

d	a	L	b	a1	e	k	Item no. Art.-No. Art.-Nr.	£					
M14	16	100	63	15,7	25	9	787-1416-100						
		112	70				787-1416-112						
		140	90				787-1416-140						
		160	100				787-1416-160						
		190	110				787-1416-190						
		250	150				787-1416-250						
M16	16	63	45	15,7	25	9	787-1616-063						
		100	63				787-1616-100						
		160	100				787-1616-160						
		250	150				787-1616-250						
	18	63	45	17,7	28	10	787-1618-063						
		80	55				787-1618-080						
		100	63				787-1618-100						
		125	85				787-1618-125						
		150	90				787-1618-150						
		160	100				787-1618-160						
M18	20	63	45	19,7	32	12	787-1820-063						
		80	55				787-1820-080						
		100	63				787-1820-100						
		125	85				787-1820-125						
		160	100				787-1820-160						
		200	125				787-1820-200						
M20	20	125	85	19,7	32	12	787-2020-125						
		200	125				787-2020-200						
		265	160				787-2020-265						
		22	80				21,7	35	14	787-2022-080			
	100	63	787-2022-100										
	125	85	787-2022-125										
160	100	787-2022-160											
M22	24	125	85	23,7	40	16	787-2224-125						
		200	125				787-2224-200						
		224	135				787-2224-224						
		280	170				787-2224-280						
		M24	28				100	70	27,7	44	18	787-2428-100	
							140	90				787-2428-140	
160	110			787-2428-160									
200	125			787-2428-200									
224	135			787-2428-224									
250	150			787-2428-250									
M24	28	290	180	27,7	44	18	787-2428-290						
		315	190				787-2428-315						
		400	240				787-2428-400						

# Standard parts Prodotti di norma Normdelar

Product class A according DIN ISO 4759 part 1  
Hardness class 8.8

Produzione di classe A secondo DIN ISO 4759, parte 1  
Resistenza di classe 8.8

Produktklass A till DIN ISO 4759 Del 1  
Hållfasthetsklass 8.8



## Universal Clamping Tools

Tecnica di fissaggio Universale • Universell Spännteknik

### Stud bolts DIN 6379

Tirante DIN 6379

Stiftskruv DIN 6379

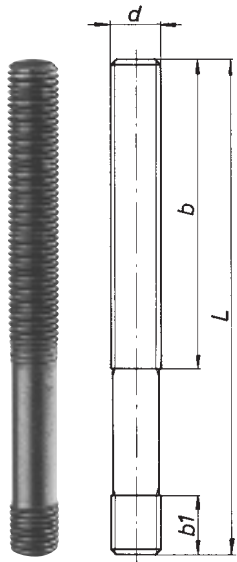

d	L	b	b1	Item no. Art.-No. Art.-Nr.	£
M06	32	16	9	379-06-032	
	50	30		379-06-050	
	80	50		379-06-080	
M08	40	20	11	379-08-040	
	63	40		379-08-063	
	100	63		379-08-100	
	160	100		379-08-160	
M10	50	25	13	379-10-050	
	80	50		379-10-080	
	100	75		379-10-100	
	125	75		379-10-125	
	140	90		379-10-140	
M12	63	32	15	379-12-063	
	100	63		379-12-100	
	125	75		379-12-125	
	150	90		379-12-150	
	200	125		379-12-200	
	265	160		379-12-265	
M14	63	32	17	379-14-063	
	100	63		379-14-100	
	125	75		379-14-125	
	160	100		379-14-160	
	200	125		379-14-200	
	250	160		379-14-250	
M16	80	50	19	379-16-080	
	100	63		379-16-100	

d	L	b	b1	Item no. Art.-No. Art.-Nr.	£
M16	125	75	19	379-16-125	
	160	100		379-16-160	
	200	125		379-16-200	
	250	160		379-16-250	
	280	160		379-16-280	
M18	125	75	23	379-18-125	
	140	80		379-18-140	
	170	100		379-18-170	
	200	125		379-18-200	
	280	160		379-18-280	
M20	80	32	27	379-20-080	
	125	70		379-20-125	
	160	100		379-20-160	
	180	110		379-20-180	
	200	125		379-20-200	
	224	130		379-20-224	
	250	160		379-20-250	
	280	160		379-20-280	
M22	160	100	31	379-22-160	
	224	130		379-22-224	
	250	160		379-22-250	
	315	180		379-22-315	
	400	250		379-22-400	
	500	315		379-22-500	
M24	100	45	35	379-24-100	
	160	100		379-24-160	
	224	130		379-24-224	
	250	160		379-24-250	
M30	200	125	43	379-30-200	
	315	200		379-30-315	
	500	315		379-30-500	
	700	400		379-30-700	

### Stud bolts with hexagon inserts

Tirante con incavo esagonale

Stiftskruv med invändig sexkant

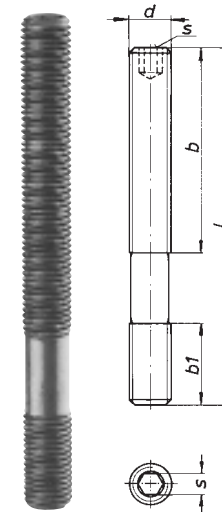

d	L	b	b1	s	Item no. Art.-No. Art.-Nr.	£
M10	112	75	15	5	380-10-112	
	140	90			380-10-140	
M12	112	75	18	6	380-12-112	
	140	90			380-12-140	
	200	125			380-12-200	
M14	125	75	21		380-14-125	
	150	95			380-14-150	
	200	125			380-14-200	
M16	125	75	24	8	380-16-125	
	160	105			380-16-160	
	200	125			380-16-200	
	280	160			380-16-280	
M18	160	100	27		380-18-160	
	212	125			380-18-212	
	280	160			380-18-280	
M20	160	100	30	10	380-20-160	
	224	125			380-20-224	
	300	160			380-20-300	
M22	224	125	33		380-22-224	
	315	180			380-22-315	
M24	250	150	36	12	380-24-250	
	315	200			380-24-315	

# Standard parts **Prodotti di norma** **Normdelar**

Product class A according DIN ISO 4759 part 1  
Hardness class 10



Produzione di classe A secondo DIN ISO 4759, parte 1  
Resistenza di classe 10

Produktklass A till DIN ISO 4759 Del 1  
Hållfasthetsklass 10

**T nuts DIN 508**  
**Tassello per cava-T DIN 508**  
**Mutter för T-spår DIN 508**

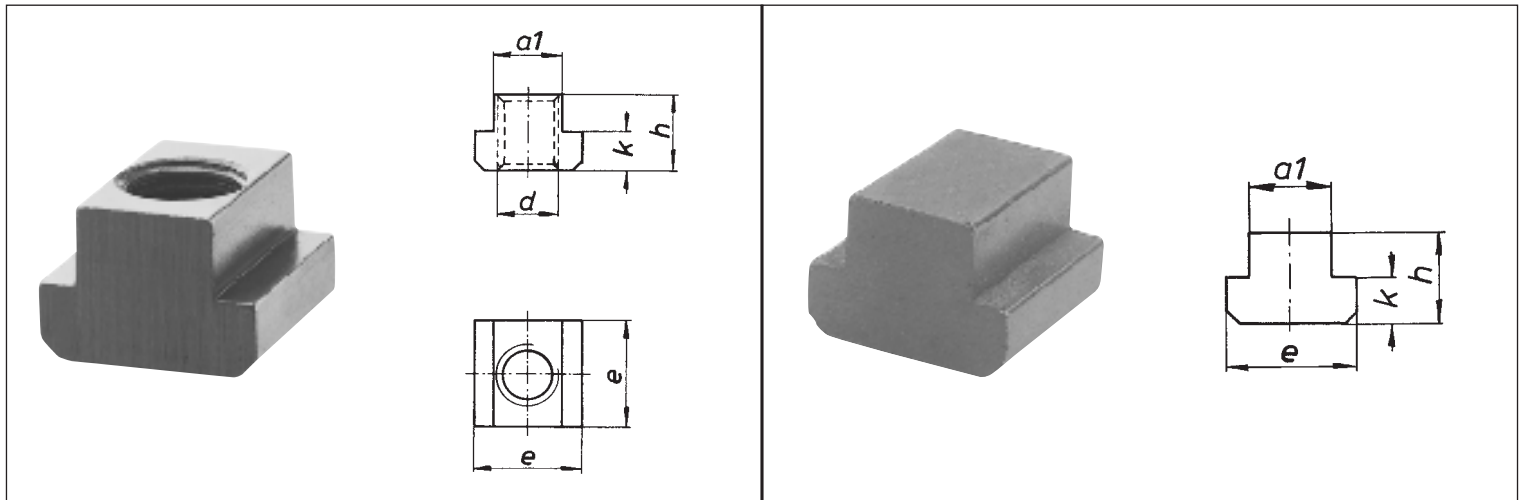
**T nuts DIN 508 (blank)**  
**Tassello per cava-T DIN 508 (non lavorato)**  
**Mutter för T-spår DIN 508 (ämne)**



d		a	a1	e	h	k	Item no. Art.-No. Art.-Nr.	£		a	a1	e	h	k	Item no. Art.-No. Art.-Nr.	£	
M05		6	5,7	10	8	4	508-0506			6	5,7	10	8	4	508-0006		
M06		8	7,7	13	10	6	508-0608			8	7,7	13	10	6	508-0008		
M08		10	9,7	15	12	6	508-0810			10	9,7	15	12	6	508-0010		
M10		12	11,7	18	14	7	508-1012			12	11,7	18	14	7	508-0012		
M12		14	13,7	22	16	8	508-1214			14	13,7	22	16	8	508-0014		
		16	15,7	25	18	9	508-1216			16	15,7	25	18	9	508-0016		
		18	17,7	28	20	10	508-1218			18	17,7	28	20	10	508-0018		
M14		16	15,7	25	18	9	508-1416			20	19,7	32	24	12	508-0020		
		18	17,7	28	20	10	508-1418			22	21,7	35	28	14	508-0022		
M16		18	17,7	28	20	10	508-1618			24	23,7	40	32	16	508-0024		
		20	19,7	32	24	12	508-1620			28	27,7	44	36	18	508-0028		
		22	21,7	35	28	14	508-1622			32	31,7	50	40	20	508-0032		
		28	27,7	44	36	18	508-1628			36	35,6	54	44	22	508-0036		
M18		20	19,7	32	24	12	508-1820										
M20		22	21,7	35	28	14	508-2022										
		24	23,7	40	32	16	508-2024										
		28	27,7	44	36	18	508-2028										
M22		24	23,7	40	32	16	508-2224										
M24		28	27,7	44	36	18	508-2428										
		32	31,7	50	40	20	508-2432										
		36	35,6	54	44	22	508-2436										
M30		36	35,6	54	44	22	508-3036										

# Standard parts Prodotti di norma Normdelar

Product class A according DIN ISO 4759 part 1  
Hardness class 10

Produzione di classe A secondo DIN ISO 4759, parte 1  
Resistenza di classe 10

Produktklass A till DIN ISO 4759 Del 1  
Hållfasthetsklass 10



## Universal Clamping Tools

Tecnica di Fissaggio Universale • Universell Spänteknik

**T nuts DIN 508 R (rhombus)**

**Tassello per cava-T DIN 508 R (rombo)**



**Mutter för T-spår DIN 508 R (rombisk)**

**T nuts DIN 508 L (long)**

**Tassello per cava-T DIN 508 L (lungo)**

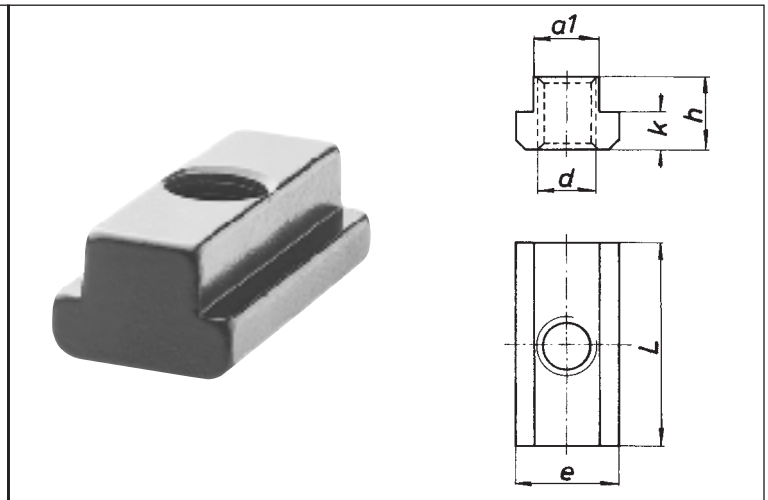
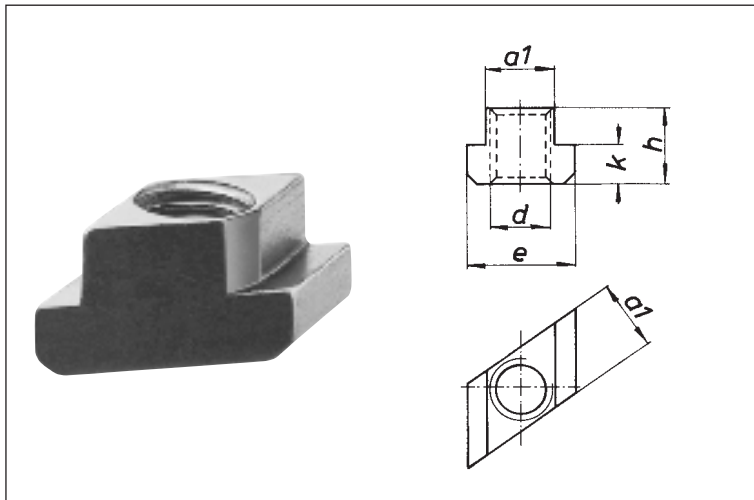
**Mutter för T-spår DIN 508 L (lång)**



d	a		a1	e	h	k	Item no. Art.-No. Art.-Nr.	£	d		a1	e	h	k	l	Item no. Art.-No. Art.-Nr.	£
M08	10		9,7	15	12	6	504-0810		M06	8	7,7	13	10	6	26	503-0608	
M10	12		11,7	18	14	7	504-1012		M08	10	9,7	15	12	6	30	503-0810	
M12	14		13,7	22	16	8	504-1214		M10	12	11,7	18	14	7	36	503-1012	
M14	16		15,7	25	18	9	504-1416		M12	14	13,7	22	16	8	44	503-1214	
M16	18		17,7	28	20	10	504-1618		M14	16	15,7	25	18	9	50	503-1416	
	20		19,7	32	24	12	504-1620		M16	18	17,7	28	20	10	56	503-1618	
	22		21,7	35	28	14	504-1622			20	19,7	32	24	12	64	503-1620	
	28		27,7	44	36	18	504-1628		M18	20	19,7	32	24	12	64	503-1820	
M18	20		19,7	32	24	12	504-1820		M20	22	21,7	35	28	14	70	503-2022	
M20	22		21,7	35	28	14	504-2022			24	23,7	40	32	16	80	503-2024	
	24		23,7	40	32	16	504-2024		M22	24	23,7	40	32	16	80	503-2224	
	28		27,7	44	36	18	504-2028		M24	28	27,7	44	36	18	88	503-2428	
M22	24		23,7	40	32	16	504-2224										
M24	28		27,7	44	36	18	504-2428										
M30	36		35,6	54	44	22	504-3036										

# Special standard parts

Prodotti di norma particolare  
Specialdelar

Product class A according DIN ISO 4759 part 1  
Hardness class 12

Produzione di classe A secondo DIN ISO 4759, parte 1  
Resistenza di classe 12

Produktklass A till DIN ISO 4759 Del 1  
Hållfasthetsklass 12

Patented.

Brevettata.

Patenterad.

**Double T nut according DIN 508**  
**Tassello per cava-T DIN 508**  
**Dubbelmutter för T-spår DIN 508**

**Extension T nuts 9°**

For clamping elements MQ 100 - MQ 130  
for stacking of clamping tools.

**Tassello di montaggio 9°**

Per gli elementi di fissaggio MQ 100 - MQ 130  
per sovrapposizione delle scarpe.

**Förlängningsmutter för T-spår 9°**

För spännelement MQ 100 - MQ 130,  
för att stapla spännskon.

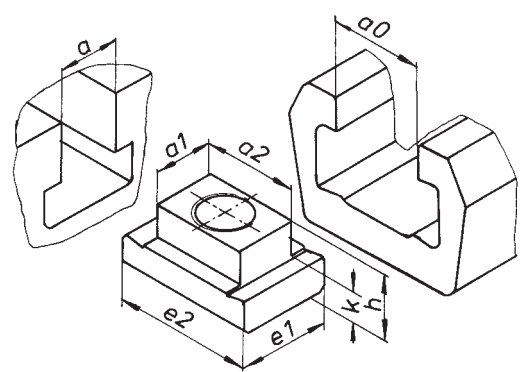
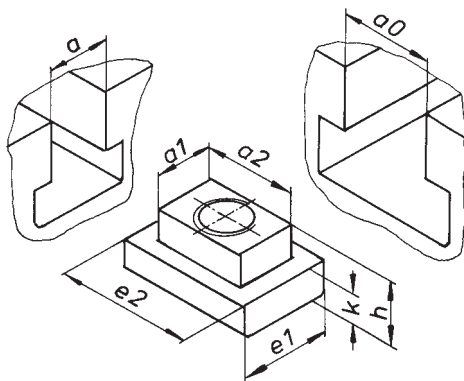
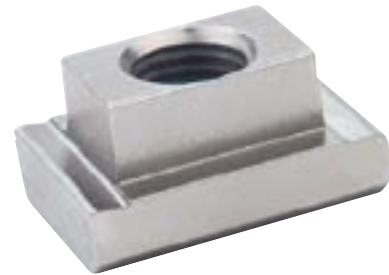
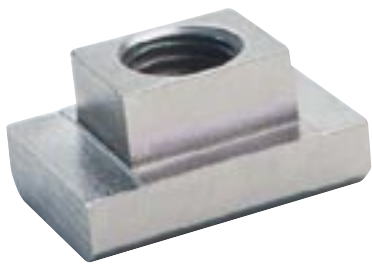

d	a	a0	a1	a2	e1	e2	h	k	Item no. Art.-No. Art.-Nr.	£	d	a	a0	a1	a2	e1	e2	h	k	Item no. Art.-No. Art.-Nr.	£		
M12	14	16	13,7	15,7	22	25	16	8	502-1214-16		M10	12	24	11,7	23,5	18	35	14	7	509-1012-24			
		18		17,7		28				502-1214-18				14		13,7		22		16	8	509-1214-24	
		20		19,7		32				502-1214-20				16	28	15,7	27,4	25	41	18	9	509-1416-28	
		22		21,7		35				502-1214-22				18		17,7		28		20	10	509-1618-28	
M16	18	20	17,7	19,7	28	32	20	10	502-1618-20		M18	20	34	19,7	33,6	32	49	24	12	509-1820-34			
		22		21,7		35				502-1618-22				22		21,7		35		25	14	509-2022-34	
		24		23,7		40				502-1618-24				28		27,7		44		31	18	509-2028-34	
		28		27,7		44				502-1618-28				M24	28	34	27,7	33,6	44	49	31	18	509-2428-34
								502-2022-24		42		41,5				61				509-2428-42			
M20	22	24	19,7	23,7	35	40	28	14	502-2022-24														
		28		27,7		44				502-2022-28													
M24	28	32	27,7	31,7	44	50	36	18	502-2428-32														
		36		35,6		54				502-2428-36													

# Special standard parts

Prodotti di norma particolare

Specialdelar

Product class A according DIN ISO 4759 part 1;

Hardness class 10

Produzione di classe A secondo DIN ISO 4759, parte 1;

Resistenza di classe 10

Produktklass A till DIN ISO 4759 Del 1; Hållfasthetsklass 10

# LENZKE

## Universal Clamping Tools

Tecnica di Fissaggio Universale • Universell Spännteknik

### T nuts high form

Tassello per cava-T alto

Mutter för T-spår hög

### V nuts

Tassello per cava-V

Mutter för V-spår

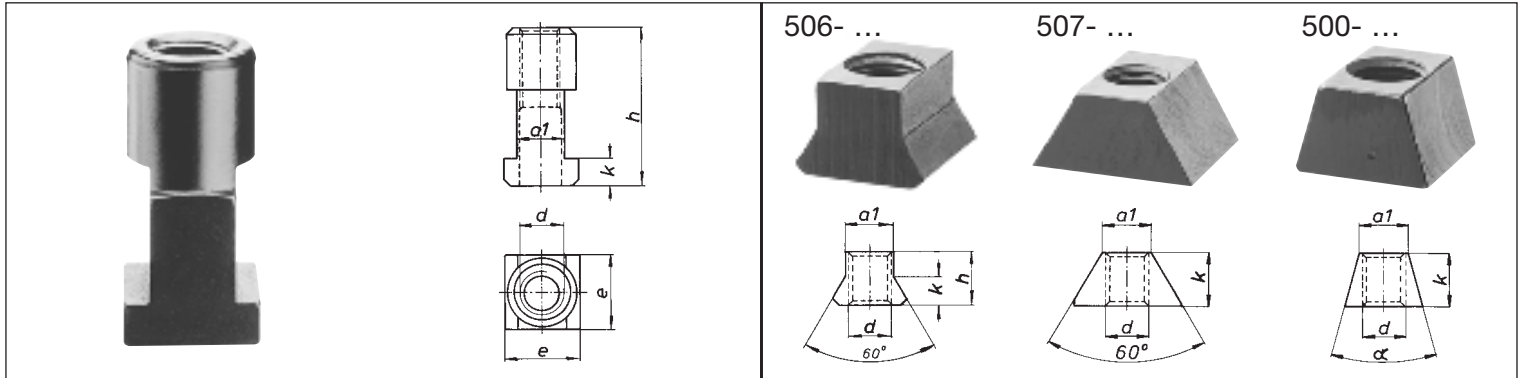

d	a	a1	e	h	k	Item no. Art.-No. Art.-Nr.	£	d	a	a1	e	h	k	α°	Item no. Art.-No. Art.-Nr.	£
M08	10	9,7	15	35	6	505-045-0810		M12	14	13,7	22	16	8	60	506-1214	
M10	12	11,7	18	38	7	505-045-1012			16	15,7	25	18	9		506-1216	
				50		505-070-1012		M14							506-1416	
				70		505-110-1012		M16	18	17,7	28	20	10		506-1618	
M12	14	13,7	22	40	8	505-045-1214			20	19,7	32	24	12		506-1620	
				52		505-070-1214		M18							506-1820	
				80		505-110-1214		M20	22	21,7	35	28	14		506-2022	
M14	16	15,7	25	44	9	505-045-1416			24	23,7	40	32	16		506-2024	
				56		505-070-1416		M24	28	27,7	44	36	18		506-2428	
				84		505-110-1416		Form A			L					
M16	18	17,7	28	47	10	505-045-1618		M12	14	14,4	30	25	15	60	507-1214	
				59		505-070-1618			18	18,4	40	35	20		507-1218	
				87		505-110-1618		M14	16	16,4	30	30	15		507-1416	
	20	19,7	32	50	12	505-045-1620		M16	18	18,4	40	40	20		507-1618	
	22	21,7	35	54	14	505-045-1622			20	20,4					507-1620	
M18	20	19,7	32	61	12	505-070-1820		M20	22	22,4	50	40	25		507-2022	
				90		505-110-1820			24	24,4					507-2024	
M20	22	21,7	35	65	14	505-070-2022		M24	28	28,4	60	45	30		507-2428	
				90		505-110-2022		Form B			L					
	24	23,7	40	68	16	505-070-2024		M12	15	15,4	25	25	15	40	500-1215.4	
				90		505-110-2024		M16	16	18,4	29	35			500-1618.4	
	28	27,7	44	73	18	505-070-2028			20	20,4	30	30	20	30	500-1620.3	
M22	24	23,7	40	90	16	505-110-2224			22	22,4	32	35			500-1622.3	
M24	28	27,7	44	100	18	505-110-2428		M20			35	40		40	500-2022.4	

# Standard parts **Prodotti di norma** **Normdelar**

Product class A according DIN ISO 4759 part 1  
Hardness class 10

Produzione di classe A secondo DIN ISO 4759, parte 1  
Resistenza di classe 10

Produktklass A till DIN ISO 4759 Del 1  
Hållfasthetsklass 10

**Hexagonal fixture nuts** DIN 6330 B 1,5d high  
**Dado esagonale** DIN 6330 B 1,5d alto  
**Sexkantsmutter** DIN 6330 B 1,5 hög

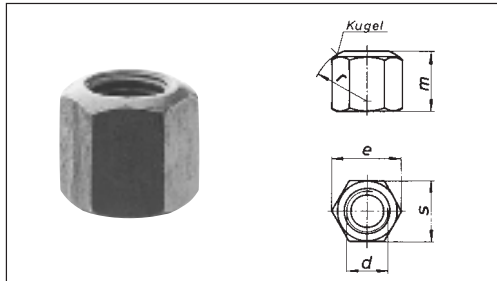

**Hexagonal collar nuts** DIN 6331  
**Dado esagonale** DIN 6331 con rondella  
**Sexkantsmutter** DIN 6331 med fläns

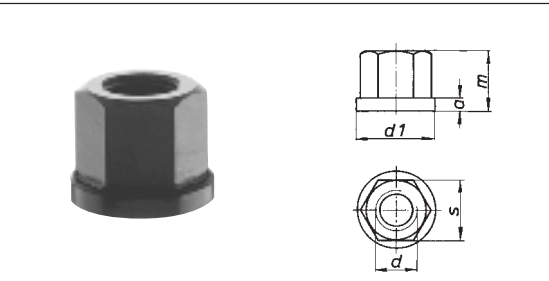

**Extension nuts** DIN 6334 3,0d high  
**Dado esagonale di prolungamento**  
DIN 6334 3,0d alto  
**Förlängningsmutter** DIN 6334 3,0d hög

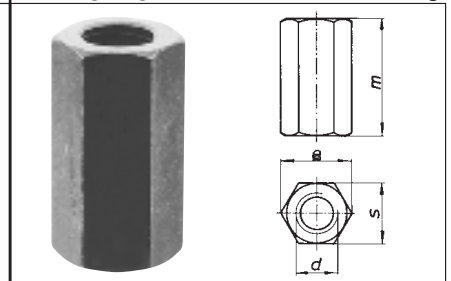

d	s	m	r	Item no. Art.-No. Art.-Nr.	£	d	s	m	a	d1	Item no. Art.-No. Art.-Nr.	£	d	s	m	Item no. Art.-No. Art.-Nr.	£
M06	10	9	9	330-06		M06	10	9	3	14	331-06		M06	10	18	334-06	
M08	13	12	12	330-08		M08	13	12	3,5	18	331-08		M08	13	24	334-08	
M10	16	15	15	330-10		M10	16	15	4	22	331-10		M10	16	30	334-10	
M12	18	18	17	330-12		M12	18	18	4	25	331-12		M12	18	36	334-12	
M14	21	21	20	330-14		M14	21	21	4,5	28	331-14		M14	21	42	334-14	
M16	24	24	22	330-16		M16	24	24	5	31	331-16		M16	24	48	334-16	
M18	27	27	24	330-18		M18	27	27	5	34	331-18		M18	27	54	334-18	
M20	30	30	27	330-20		M20	30	30	6	37	331-20		M20	30	60	334-20	
M22	34	33	30	330-22		M22	34	33	6	40	331-22		M22	34	66	334-22	
M24	36	36	32	330-24		M24	36	36	6	45	331-24		M24	36	72	334-24	
M30	46	45	41	330-30		M30	46	45	8	58	331-30		M30	46	90	334-30	

## T bolt sets for T slots

complete  
with wooden box

### Assortimento di fissaggio per cava-T

completa di scatola  
di legno

### Spännskruvsats för T-spår

komplett i träask



Item no., Art.-No., Art.-Nr.	391-1214	391-1416	391-1618	391-1820	391-2022	391-2428
Threads, Filettatura, Gänga	M12 a14	M14 a16	M16 a18	M18 a20	M20 a22	M24 a28
Piece x length, Pezzo x lunghezza, Antal x längd	St x L	St x L	St x L	St x L	St x L	St x L
T slot bolts Bulloni per cava-T Skruv för T-spår	DIN 787	4 x 050	4 x 063	4 x 080	4 x 125	4 x 100
		4 x 080	4 x 100	4 x 125	4 x 160	4 x 160
		4 x 125	4 x 160	4 x 160	4 x 200	4 x 200
		4 x 180	4 x 190	4 x 200	4 x 265	4 x 280
Stud bolts Prigionieri-tiranti Stiftskruv	DIN 6379	4 x 100	4 x 100	4 x 100	4 x 125	4 x 125
		4 x 150	4 x 160	4 x 160	4 x 170	4 x 180
		4 x 200	4 x 200	4 x 200	4 x 212	4 x 224
		4 x 265	4 x 265	4 x 280	4 x 280	4 x 280
Flat washers Rondelle Bricka	DIN 6340	4	4	4	4	4
Hexagonal collar nuts Dadi esagonali con rondelle Sexkantsmutter med fläns	DIN 6331	4	4	4	4	4
Extension nuts Dadi esagonali di prolungamento Förlängningsmutter	DIN 6334	4	4	4	4	4
T nuts Dadi per cava-T Mutter för T-spår	DIN 508	4	4	4	4	4
T nuts long Dadi per cava-T lunghi Mutter för T-spår lång	DIN 508 L	2	2	2	2	2
Spherical seat washers C + G Rondelle articolate C + G Kulformad bricka C + G	DIN 6319	2	2	2	2	2
Bolt paste, Impasto per viti, Gängpasta		1	1	1	1	1
£/Set, £/Serie, £/Sats						

**Spherical seat washers form C** DIN 6319  
**Rondella piana forma C** DIN 6319  
**Kulformad bricka Form C** DIN 6319

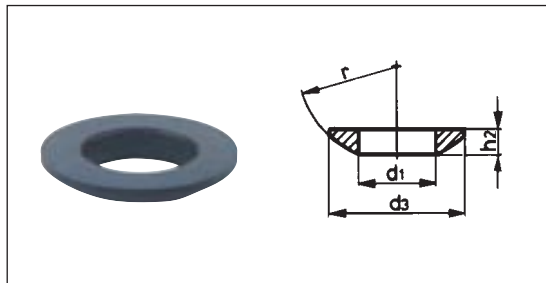

**Dished washers form D** DIN 6319  
**Rondella piana forma D** DIN 6319  
**Platt bricka Form D** DIN 6319

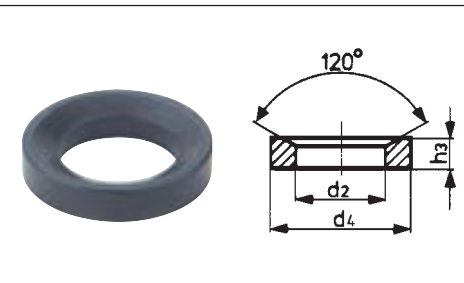

**Large dished washers form G** DIN 6319  
**Rondella piana forma G** DIN 6319  
**Platt bricka Form G** DIN 6319

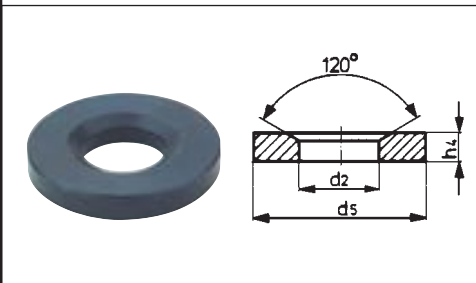

d	d1	d3	h2	r	Item no. Art.-No. Art.-Nr.	£
M08	8,4	17	3,2	12	319-108	
M10	10,5	21	4,0	15	319-110	
M12	13	24	4,6	17	319-112	
M14	15	28	5,0	22	319-114	
M16	17	30	5,3	22	319-116	
M20	21	36	6,3	27	319-120	
M24	25	44	8,2	32	319-124	
M30	31	56	11,2	41	319-130	

Insert hardened, hardness 550 +100 HV10  
Temperato ai margini, resistenza 550 +100 HV10  
Insatshårdad, hårdhet 550 +100 HV10

d	d2	d4	h3	Item no. Art.-No. Art.-Nr.	£
M08	9,6	17	3,5	319-208	
M10	12	21	4,2	319-210	
M12	14,2	24	5	319-212	
M14	16,5	28	5,6	319-214	
M16	19	30	6,2	319-216	
M20	23,2	36	7,5	319-220	
M24	28	44	9,5	319-224	
M30	35	56	12	319-230	

Insert hardened, hardness 550 +100 HV10  
Temperato ai margini, resistenza 550 +100 HV10  
Insatshårdad, hårdhet 550 +100 HV10

d	d2	d5	h4	Item no. Art.-No. Art.-Nr.	£
M08	9,6	24	5	319-308	
M10	12	30	5	319-310	
M12	14,2	36	6	319-312	
M14	16,5	40	6	319-314	
M16	19	44	7	319-316	
M20	23,2	50	8	319-320	
M24	28	60	10	319-324	
M30	35	68	12	319-330	

Tempered, hardness 350 + 80 HV30  
Bonificata, resistenza 350 + 80 HV30  
Special behandlad, hårdhet 350 + 80 HV30

### Washers DIN 6340

Product class A DIN 522, tempered  
Hardness 350 + 80 HV30

### Rondella DIN 6340

Produzione di classe A secondo DIN 522, bonificata  
Resistenza 350 + 80 HV30

### Bricka DIN 6340

Produktklass A DIN 522  
Special behandlad, hårdhet 350 + 80 HV30

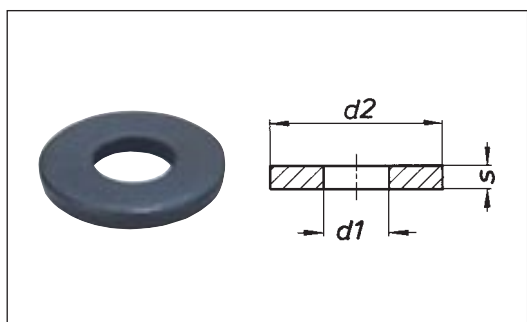

d	d1	d2	s	Item no. Art.-No. Art.-Nr.	£
M06	6,4	17	3	340-06	
M08	8,4	23	4	340-08	
		18	3	340-081	
M10	10,5	28	4	340-10	
M12	13,0	35	5	340-12	
		30		340-121	
M14	15,0	40		340-14	
		32		340-141	
M16	17,0	45	6	340-16	
		32	5	340-161	
		40		340-162	
M18	19,0	45	6	340-18	
		40	5	340-181	
M20	21,0	50	6	340-20	
		40	5	340-201	
M22	23,0	50	8	340-22	
M24	25,0	60	8	340-24	
M30	31,0	68	10	340-30	
M36	38,0	80	12	340-36	

### Combination wrench

DIN 3113, chrome plated

### Chiave ad anello

DIN 3113, cromata

### U-rings Nyckel

DIN 3113, Förokromad



s	l	Item no. Art.-No. Art.-Nr.	£
13	160	620-13	
16	180	620-16	
18	200	620-18	
21	260	620-21	
24	280	620-24	
27	300	620-27	
30	330	620-30	
34	450	620-34	
36	460	620-36	

# Special standard parts

Prodotti di norma particolare  
Specialdelar

Product class A according DIN ISO 4759 part 1  
Hardness class 12.9/10.9

Produzione di classe A secondo DIN ISO 4759, parte 1  
Resistenza di classe 12.9/10.9

Produktklass A till DIN ISO 4759 Del 1  
Hållfasthetsklass 12.9/10.9

**Countersunk screws** 12.9  
with hexagonal inserts  
**Vite a testa piatta** con incavo esagonale  
**Insexskruv**

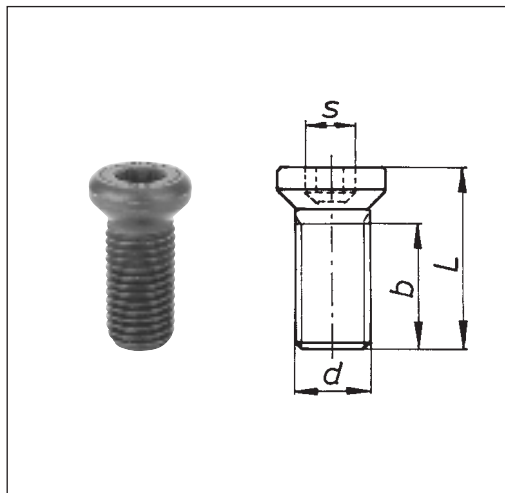

**Hexagon high head screws** 10.9  
**Vite esagonale** con testa alta  
**Sexkantskruv**  
med förhöjd skalle

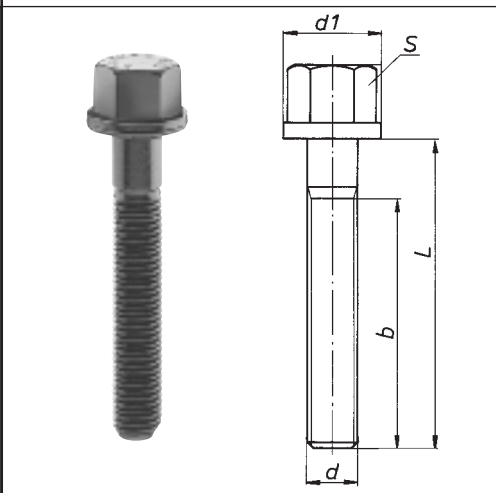

**Ball pressure screws** 12.9  
with hexagonal inserts  
**Vite a sfera** con incavo esagonale  
**Tryckskruv**  
med invändig sexkant

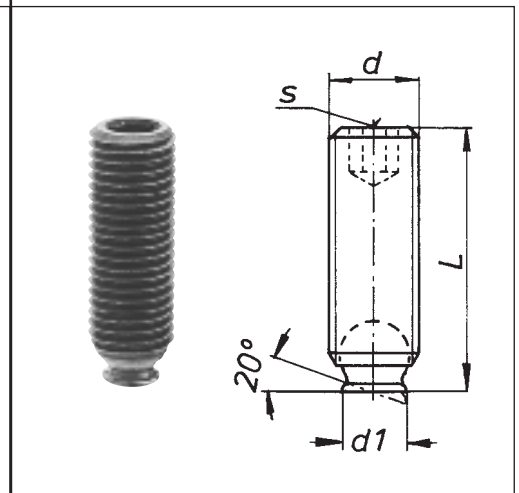

d	L	b	s	Item no. Art.-No. Art.-Nr.	£
M08	25	13	8	390-08-025	
M10	29	19		390-10-029	
M12	27	17		390-12-027	
	31	21		390-12-031	
	35	25		390-12-035	
	38	28		390-12-038	
M14	35	24	10	390-14-035	
	41	30		390-14-041	
	48	39		390-14-048	
M16	35	25		390-16-035	
	40	30		390-16-040	
	45	35		390-16-045	
	55	44		390-16-055	
M18	45	31	12	390-18-045	
	51	37		390-18-051	
	60	45		390-18-060	
M20	42	28		390-20-042	
	51	37		390-20-051	
	55	43		390-20-055	
	60	45		390-20-060	
M22	70	55		390-20-070	
	58	43		390-22-058	
	80	60		390-22-080	
M24	50	35		390-24-050	
	60	46		390-24-060	
	90	74		390-24-090	
M30	60	45		390-30-060	
	75	60		390-30-075	
	86	70		390-30-086	
M36	66	52		390-36-066	

d	L	b	k	s	Item no. Art.-No. Art.-Nr.	£
M08	65	40	11	13	385-08-065	
M10	65	45	14	16	385-10-065	
	75	60			385-10-075	
	100	80			385-10-100	
M12	65	45	16	18	385-12-065	
	80	60			385-12-080	
	105	90			385-12-105	
M14	70	50	19	21	385-14-070	
	85	65			385-14-085	
	110	90			385-14-110	
	175	90			385-14-175	
M16	75	60	21	24	385-16-075	
	80	70			385-16-080	
	85	70			385-16-085	
	110	95			385-16-110	
M18	175	95			385-16-175	
	95	70	24	27	385-18-095	
	115	100			385-18-115	
	180	100			385-18-180	
M20	95	80	26	30	385-20-095	
	105	95			385-20-105	
	120	100			385-20-120	
M22	130	100			385-20-130	
	185	100			385-20-185	
	130	100	28	34	385-22-130	
M24	190	110			385-22-190	
	130	110	30	36	385-24-130	
	190	110			385-24-190	

d	L	d1	s	Item no. Art.-No. Art.-Nr.	£
M16	45	12	8	310-16-045	
	50			310-16-050	
	55			310-16-055	
M20	55	15	10	310-20-055	
	60			310-20-060	
M24	60	18	12	310-24-060	
	70			310-24-070	
	80			310-24-080	
	90			310-24-090	

# Special standard parts

Prodotti di norma particolare  
Specialdelar



## Universal Clamping Tools

Tecnica di Fissaggio Universale • Universell Spänntechnik

### Work-piece protection plate

Item no. 991-...-1-3 for clamping elements MQ70 – MQ130 are used for clamping of soft materials. Quality steel, hardened.

### Piastrina di protezione

Art.-No. 991-...-1-3 per elementi di fissaggio MQ70 – MQ130 vengono utilizzati nella lavorazione di materiali morbidi e superfici lavorate. Acciaio speciale temperato.

### Tryckbricka

Art.-Nr. 991-...-1-3 för spännelement MQ70 – MQ130 finns en tryckbricka som skyddar materialet och den bearbetade ytan. Kvalitetsstål, härdad.

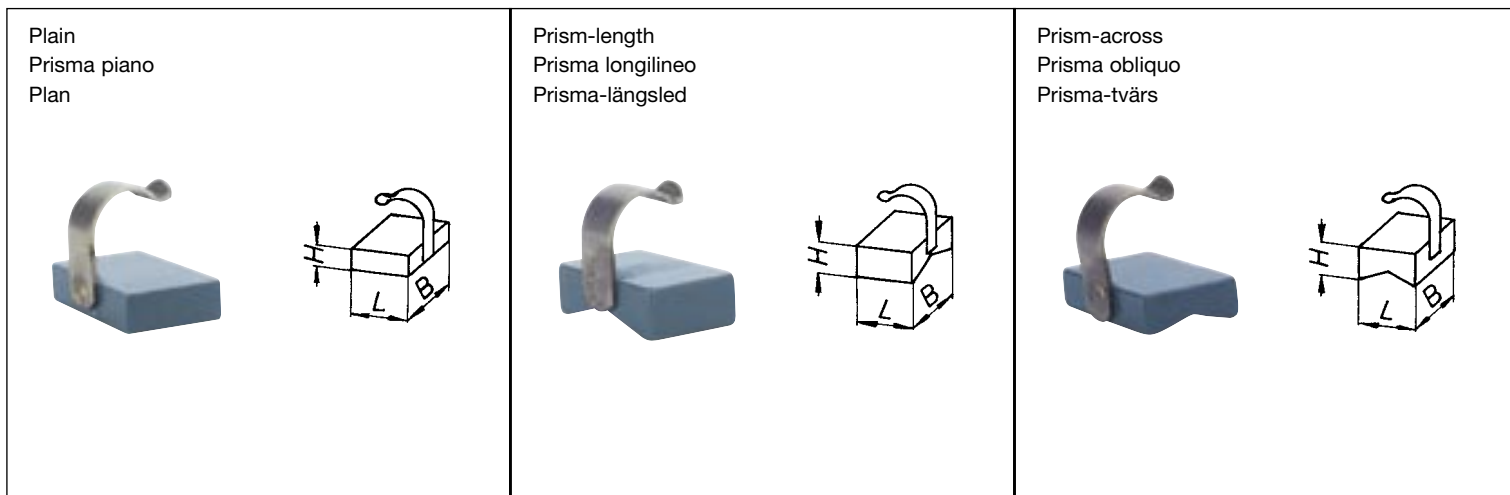

Gr.	L	B	H	Item no. Art.-No. Art.-Nr.	£	Gr.	L	B	H	Item no. Art.-No. Art.-Nr.	£	Gr.	L	B	H	Item no. Art.-No. Art.-Nr.	£
12	15	22	6	991-7012-1		12	14	22	9	991-7012-2		12	14	22	9	991-7012-3	
16		26		991-7016-1		16		26		991-7016-2		16		26		991-7016-3	
20	20	32	8	991-7020-1		20	20	32	10	991-7020-2		20	20	32	10	991-7020-3	
24		40		991-7024-1		24		40	12	991-7024-2		24		40	12	991-7024-3	

### Hexagonal allen key

with ball head, Chrome-vanadium steel, hardened

### Chiave esagonale

con testa a sfera, acciaio cromo vanadio

### Insexnyckel

med klotformat huvud, Krom-Vanadium-stål, härdad

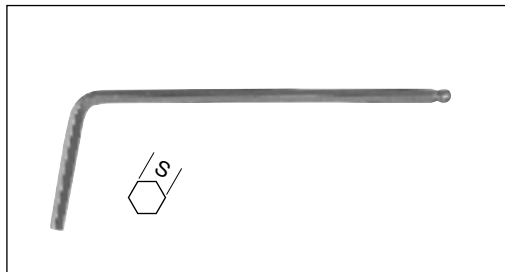

### Hexagonal allen key

with cone, Chrome-vanadium steel, hardened

### Chiave esagonale

con zaffo, acciaio cromo vanadio

### Insexnyckel

med tapp huvud, Krom-Vanadium-stål, härdad

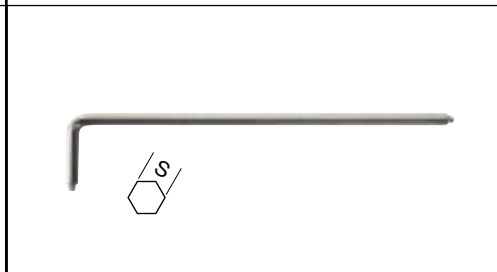

### Torque wrench

with adapter

### Chiave dinamometrica esagonale

### Momentnyckel

med sexkantsats

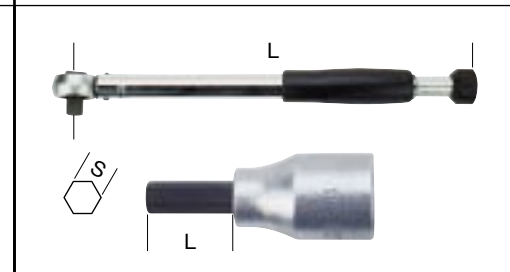

S	L1	L2	Item no. Art.-No. Art.-Nr.	£	S	L1	L2	d	Item no. Art.-No. Art.-Nr.	£	Nm	L	Item no. Art.-No. Art.-Nr.	£
6	160	60	610-06		4	140	25	2,5	611-04		10-060	380	605-060	
8	200	70	610-08		5	160	28	3	611-05		30-130	470	605-130	
10	230	80	610-10		6	180	32	4	611-06		60-300	540	605-300	
12	260	90	610-12		8	200	36	5	611-08					
14	280	95	610-14		10	224	40	6	611-10		S	L		
					12	250	45	7	611-12		8	60	606-08	
					14	280	55	8	611-14		10	60	606-10	
					17	320	63	10	611-17		12	60	606-12	

# ABOUT US SU NOI DELLA LENZKES OM LENZKES



With over 25 years experience and over 80,000 satisfied customers world-wide, Lenzkes is renowned for its high quality workholding solutions.



80.000 clienti in tutto il mondo in 25 anni di attività nel campo del fissaggio di alta qualità.



Med över 25 års erfarenhet och mer än 80.000 nöjda kunder. Är Lenzkes kända för sin höga kvalite.



## Universal Clamping Tools

Tecnica di fissaggio Universale • Universell Spännteknik

L.C.T (GB) Ltd. • Universal House  
Fairfield Park • Manvers • Rotherham • South Yorkshire S63 5DB  
Tel: 0 17 09 87 00 00 • Fax: 0 17 09 87 00 10  
Internet: [www.lctgb.ltd.uk](http://www.lctgb.ltd.uk) • E-mail: [derek@lctgb.ltd.uk](mailto:derek@lctgb.ltd.uk)