

# TECHNICAL DATA OF BALL SCREWS

## MOUNTING ACCURACY AND TOLERANCE OF BALL SCREW

### •ACCURACY OF EACH PART OF SCREW SHAFT

Tables 7 and 8 show the tolerance of the radial circumferential runout of the thread groove surface and mounting portions to the axial line of screw shaft support and that of the squareness of the end face of the support to the axial line of screw shaft support.

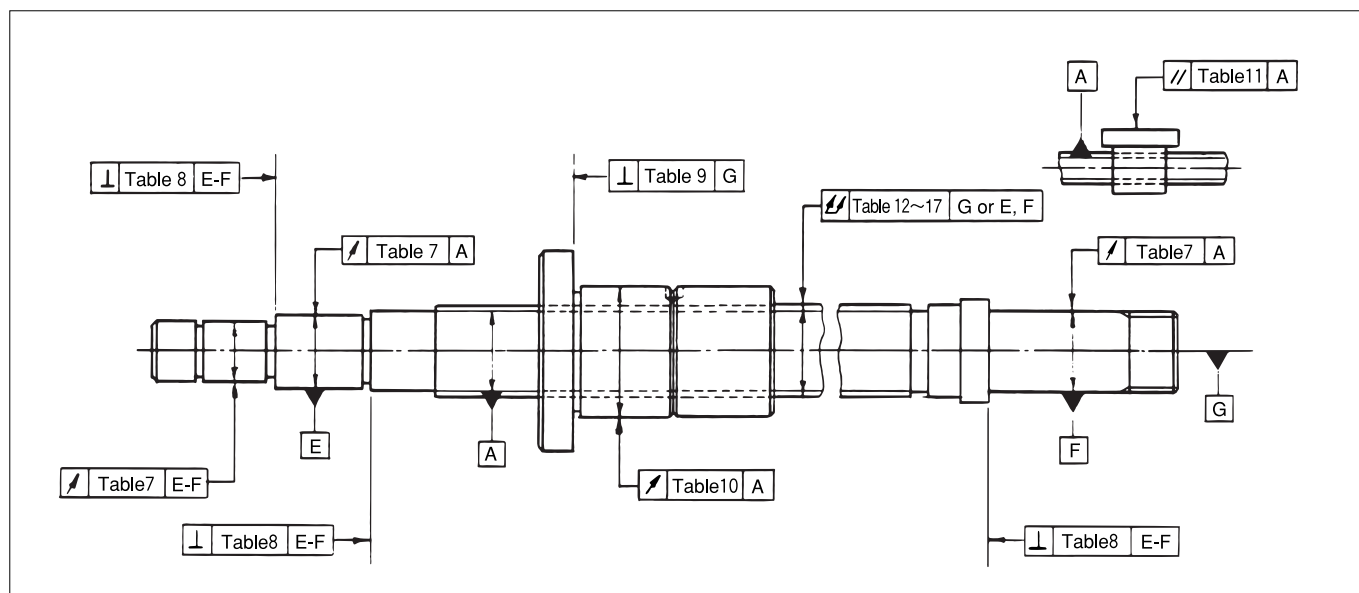

Fig. 5 Mounting Accuracy and Tolerance

Table 7 Radial circumferential runout of thread groove surface to axial line of screw shaft support and radial circumferential runout of mounting portions to axial line of screw shaft support (Unit:μm)

Nominal screw shaft diameter (mm)		Tolerable runout (maximum)					
Over	or less	C0	C1	C2	C3	C4	C5
—	8	3	5	7	8	9	10
8	12	4	5	7	8	9	11
12	20	4	6	8	9	10	12
20	32	5	7	9	10	11	13
32	50	6	8	10	12	13	15
50	80	7	9	11	13	15	17
80	125	—	10	12	15	17	20

(Note) As the measurements of this item include the influence of the runout of the screw shaft axial line, it is necessary to correct the measurements.

Calculate the correction value by using the total runouts(tolerance)of the screw shaft axial line shown in Tables 12 to 17 corresponding to the ratio of the overall length of screw shaft to the distance between the supporting point and the measuring point and add it to the tolerance shown in the above table.

Table 8 Squareness of end face of support to axial line of screw shaft support (Unit:μm)

Nominal screw shaft diameter (mm)		Tolerable squareness (axial runout) (maximum)					
Over	Or less	C0	C1	C2	C3	C4	C5
—	8	2	3	3	4	4	5
8	12	2	3	3	4	4	5
12	20	2	3	3	4	4	5
20	32	2	3	3	4	4	5
32	50	2	3	3	4	5	5
50	80	3	4	4	5	6	7
80	125	—	4	5	6	7	8

## •ACCURACY OF NUT MOUNTING PORTION

Table 9, 10 and 11 show the tolerance of the squareness of the reference end face of the nut or flange mounting surface to the axial line of the screw shaft which is used as a basis for mounting, that of the radial circumferential runout and the parallelism of the peripheral surface (cylinder or plane) of the nut to the axial line of screw shaft respectively.

Table 9 Squareness (axial runout) of reference end face of nut  
or flange mounting surface to axial line of screw shaft (Unit:μm)

Outer diameter of nut (mm)		Tolerable squareness (axial runout) (maximum)					
Over	Or less	C0	C1	C2	C3	C4	C5
–	20	5	6	7	8	9	10
20	32	5	6	7	8	9	10
32	50	6	7	8	8	10	11
50	80	7	8	9	10	11	13
80	125	7	9	10	12	13	15
125	160	8	10	11	13	15	17
160	200	–	11	12	14	16	18
200	250	–	12	13	15	17	20

Table 10 Radial circumferential runout of peripheral surface (cylinder)  
of nut to axial line of screw shaft (Unit:μm)

Outer diameter of nut (mm)		Tolerable runout (maximum)					
Over	Or less	C0	C1	C2	C3	C4	C5
–	20	5	6	7	9	10	12
20	32	6	7	8	10	11	12
32	50	7	8	10	12	13	15
50	80	8	10	12	15	17	19
80	125	9	12	16	20	23	27
125	160	10	13	17	22	26	30
160	200	–	16	20	25	29	34
200	250	–	18	23	28	33	38

Table 11 Parallelism of reference surface (rectangle) of nut  
to axial line of screw shaft (Unit:μm)

Basic mounting length (mm)		Tolerable parallelism (maximum)					
Over	Or less	C0	C1	C2	C3	C4	C5
–	50	5	6	7	8	9	10
50	100	7	8	9	10	11	13
100	200	–	10	11	13	15	17

# TECHNICAL DATA OF BALL SCREWS

## •TOTAL RUNOUT OF AXIAL CENTER OF SCREW SHAFT

Table 12 to 17 show the permissible values for total runout of the axial center of screw shaft.

Table 12 Total runout of axial center of screw shaft (C0) (Unit:mm)

Nominal screw shaft diameter		Overall length of screw shaft		Over	—	8	12	20	32	50	80
		Over	Or less	Or less	8	12	20	32	50	80	125
-	125				0.015	0.015	0.015				
125	200				0.025	0.020	0.020	0.015			
200	315				0.035	0.025	0.020	0.020			
315	400					0.035	0.025	0.020	0.015		
400	500					0.045	0.035	0.025	0.020		
500	630					0.050	0.040	0.030	0.020	0.015	
630	800						0.050	0.035	0.025	0.020	
800	1000						0.065	0.045	0.030	0.025	
1000	1250						0.085	0.055	0.040	0.030	
1250	1600						0.110	0.070	0.050	0.040	
1600	2000							0.095	0.065	0.045	

Table 13 Total runout of axial center of screw shaft (C1) (Unit:mm)

Nominal screw shaft diameter		Overall length of screw shaft		Over	—	8	12	20	32	50	80
		Over	Or less	Or less	8	12	20	32	50	80	125
-	125				0.020	0.020	0.015				
125	200				0.030	0.025	0.020	0.020			
200	315				0.040	0.030	0.025	0.020			
315	400				0.045	0.040	0.030	0.025	0.020		
400	500					0.050	0.040	0.030	0.025		
500	630					0.060	0.045	0.035	0.025	0.020	
630	800						0.060	0.040	0.030	0.025	
800	1000						0.075	0.055	0.040	0.030	
1000	1250						0.095	0.065	0.045	0.035	0.030
1250	1600						0.130	0.085	0.060	0.045	0.035
1600	2000							0.120	0.080	0.055	0.040
2000	2500								0.100	0.070	0.050
2500	3150								0.130	0.090	0.060
3150	4000									0.120	0.080

Table 14 Total runout of axial center of screw shaft (C2) (Unit:mm)

Nominal screw shaft diameter		Overall length of screw shaft		Over	—	8	12	20	32	50	80
		Over	Or less	Or less	8	12	20	32	50	80	125
-	125				0.025	0.020	0.020				
125	200				0.035	0.030	0.020	0.025			
200	315				0.045	0.035	0.025	0.025			
315	400				0.050	0.045	0.035	0.030	0.025		
400	500					0.055	0.045	0.035	0.025		
500	630					0.065	0.050	0.040	0.030	0.025	
630	800						0.065	0.045	0.035	0.030	
800	1000						0.080	0.060	0.045	0.035	
1000	1250						0.105	0.070	0.050	0.040	0.030
1250	1600						0.140	0.095	0.065	0.050	0.035
1600	2000							0.130	0.090	0.065	0.045
2000	2500								0.110	0.080	0.055
2500	3150								0.140	0.100	0.065
3150	4000									0.130	0.090
4000	5000										0.110

Table 15 Total runout of axial center of screw shaft (C3) (Unit:mm)

Overall length of screw shaft		Nominal screw shaft diameter		Over	—	8	12	20	32	50	80
		Over	Or less	Or less	8	12	20	32	50	80	125
-	125				0.025	0.025	0.020				
125	200				0.035	0.035	0.025	0.020			
200	315				0.050	0.040	0.030	0.030			
315	400				0.060	0.050	0.040	0.035	0.025		
400	500					0.065	0.050	0.040	0.030		
500	630					0.080	0.055	0.045	0.035	0.030	
630	800						0.070	0.055	0.040	0.035	
800	1000						0.095	0.065	0.050	0.040	0.030
1000	1250						0.120	0.085	0.060	0.045	0.035
1250	1600						0.160	0.110	0.075	0.055	0.040
1600	2000							0.140	0.095	0.070	0.050
2000	2500								0.120	0.085	0.060
2500	3150								0.160	0.110	0.075
3150	4000								0.220	0.150	0.100
4000	5000									0.200	0.130

Table 16 Total runout of axial center of screw shaft (C4) (Unit:mm)

Overall length of screw shaft		Nominal screw shaft diameter		Over	—	8	12	20	32	50	80
		Over	Or less	Or less	8	12	20	32	50	80	125
-	125				0.030	0.030	0.030				
125	200				0.040	0.040	0.035	0.030			
200	315				0.055	0.050	0.040	0.035			
315	400				0.070	0.060	0.050	0.040	0.035		
400	500					0.075	0.055	0.050	0.040		
500	630					0.090	0.070	0.055	0.050	0.035	
630	800						0.080	0.065	0.055	0.040	
800	1000						0.100	0.070	0.060	0.050	0.035
1000	1250						0.130	0.090	0.070	0.055	0.040
1250	1600						0.170	0.120	0.080	0.060	0.045
1600	2000							0.150	0.110	0.080	0.060
2000	2500								0.130	0.100	0.070
2500	3150								0.180	0.130	0.090
3150	4000								0.240	0.170	0.120
4000	5000									0.220	0.150

Table 17 Total runout of axial center of screw shaft (C5) (Unit:mm)

Overall length of screw shaft		Nominal screw shaft diameter		Over	—	8	12	20	32	50	80
		Over	Or less	Or less	8	12	20	32	50	80	125
-	125				0.035	0.035	0.035				
125	200				0.050	0.040	0.040	0.035			
200	315				0.065	0.055	0.045	0.040			
315	400				0.075	0.065	0.055	0.045	0.035		
400	500					0.080	0.060	0.050	0.045		
500	630					0.090	0.075	0.060	0.050	0.040	
630	800						0.090	0.070	0.055	0.045	
800	1000						0.120	0.085	0.065	0.050	0.045
1000	1250						0.150	0.100	0.075	0.060	0.050
1250	1600						0.190	0.130	0.095	0.070	0.055
1600	2000							0.170	0.120	0.085	0.065
2000	2500								0.150	0.110	0.080
2500	3150								0.200	0.140	0.095
3150	4000								0.260	0.180	0.120
4000	5000									0.240	0.160
5000	6300									0.320	0.210