

SUPPORT UNITS

SUPPORT UNITS FOR MACHINE TOOLS/BUT



Applicable ball screw size $\varnothing 25$ - $\varnothing 50$

Compact and easy mounting

Compact and space-saving design. Preloaded duplex angular ball bearings are incorporated in the support unit, allowing direct mounting. The lock nut with anti-slacking mechanism improves the mounting accuracy.

High accuracy and high rigidity

DF type, P4-grade prelubricated duplex ball bearing with contact angle of 60° assures high accuracy and high rigidity.

Dustproofing

Seals are provided on both ends of bearing for dustproofing.

Short delivery time and reasonable price

For your specific requirements regarding bearing combinations such as DFD, DFF and special configurations, contact KURODA.

NOTATION OF MODEL NUMBER

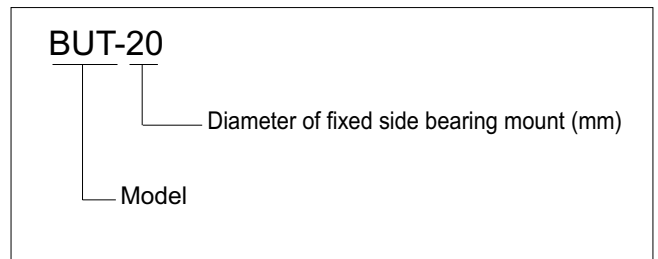

RECOMENDABLE COMBINATION WITH BALL SCREW

Model No.	Diameter of fixed side bearing mount(mm)	Applicable ball screw size (mm)
BUT-20	$\varnothing 20$	$\varnothing 25, \varnothing 28$
BUT-25	$\varnothing 25$	$\varnothing 32, \varnothing 36$
BUT-30	$\varnothing 30$	$\varnothing 36, \varnothing 40$
BUT-35	$\varnothing 35$	$\varnothing 40, \varnothing 45$
BUT-40	$\varnothing 40$	$\varnothing 50$

(Note) Contact KURODA for other combinations with ball screw as above.

BALL SCREWS/ ACCESSORIES

DIAMETER OF BEARING MOUNT

Tolerance of the bearing mount shown in the following table is recommended.

Support unit	Diameter of fixed side bearing mount(mm)
BUT-20	$\text{Ø}20_{-0.012}^{-0.003}$
BUT-25	$\text{Ø}25_{-0.012}^{-0.003}$
BUT-30	$\text{Ø}30_{-0.012}^{-0.003}$
BUT-35	$\text{Ø}35_{-0.015}^{-0.004}$
BUT-40	$\text{Ø}40_{-0.015}^{-0.004}$

CONSTRUCTION AND MAIN PARTS

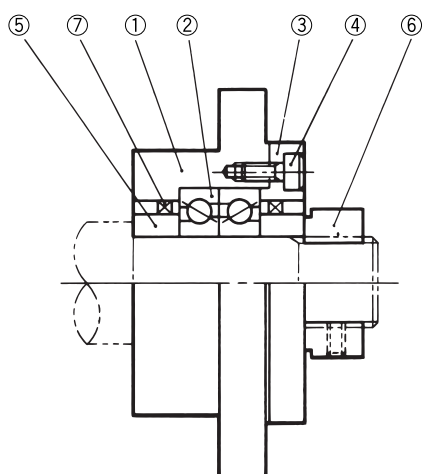

No.	Description	Q'ty
①	Bearing housing	1
②	Bearing	1 set
③	Cover	1
④	Hexagon socket head cap screw	6 or 8
⑤	Spacer	2
⑥	Lock nut	1
⑦	Oil seal	2

(Note)As ①, ② and ③ are united, do not disassemble the unit.

SUPPORT UNITS

Support unit for machine tools/BUT-20

(Unit:mm)

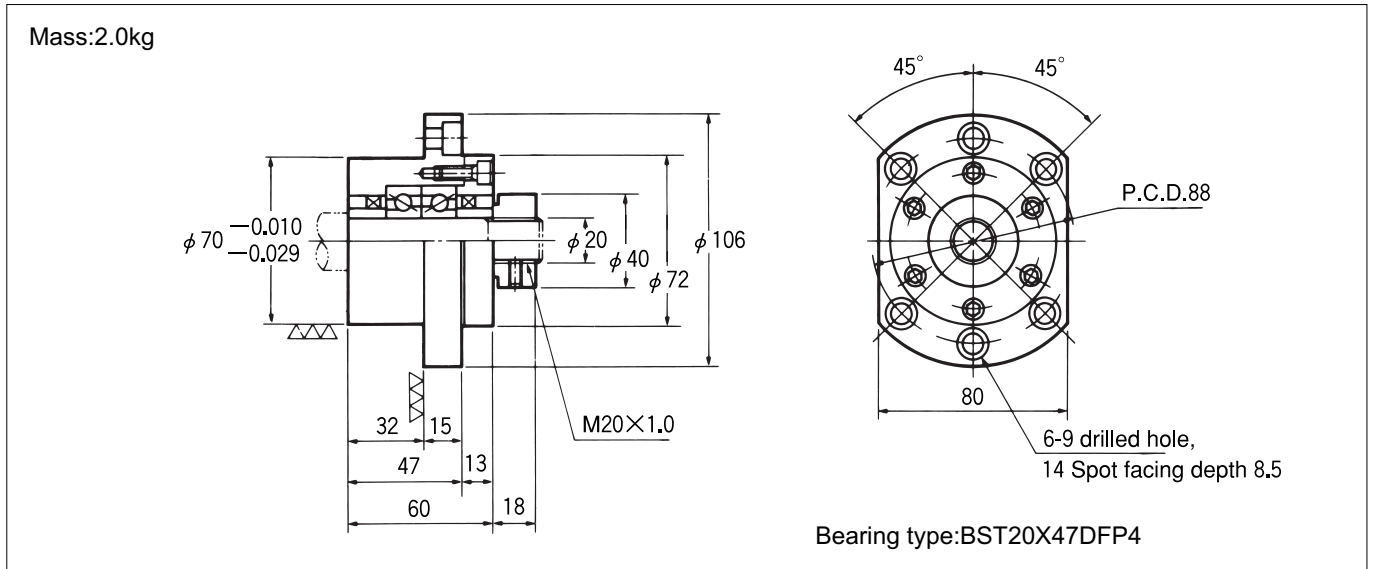

Support unit for machine tools/BUT-25

(Unit:mm)

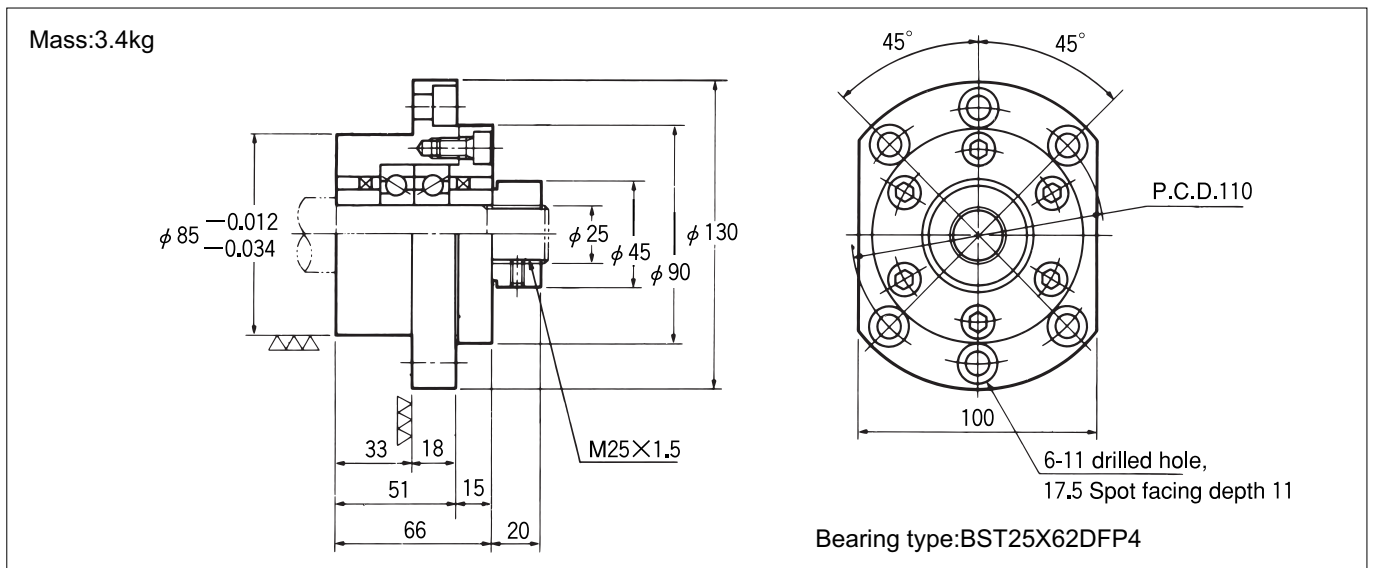

Support unit for machine tools/BUT-30

(Unit:mm)

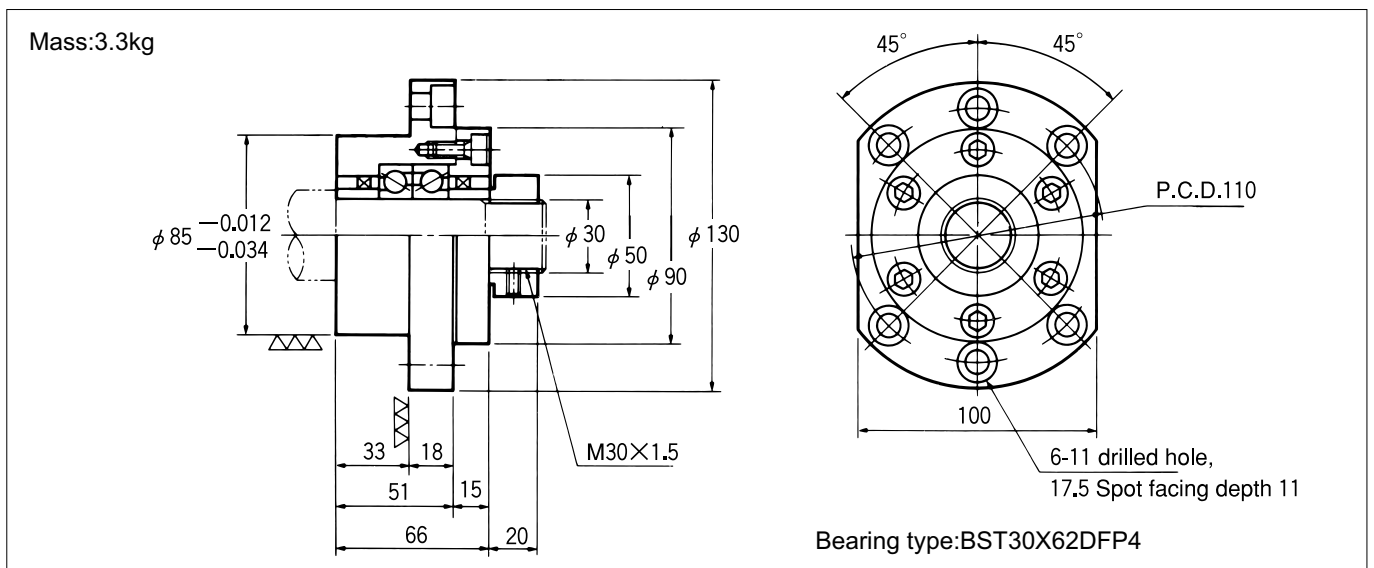

BALL SCREWS
ACCESSORIES

Support unit for machine tools/BUT-35

(Unit:mm)

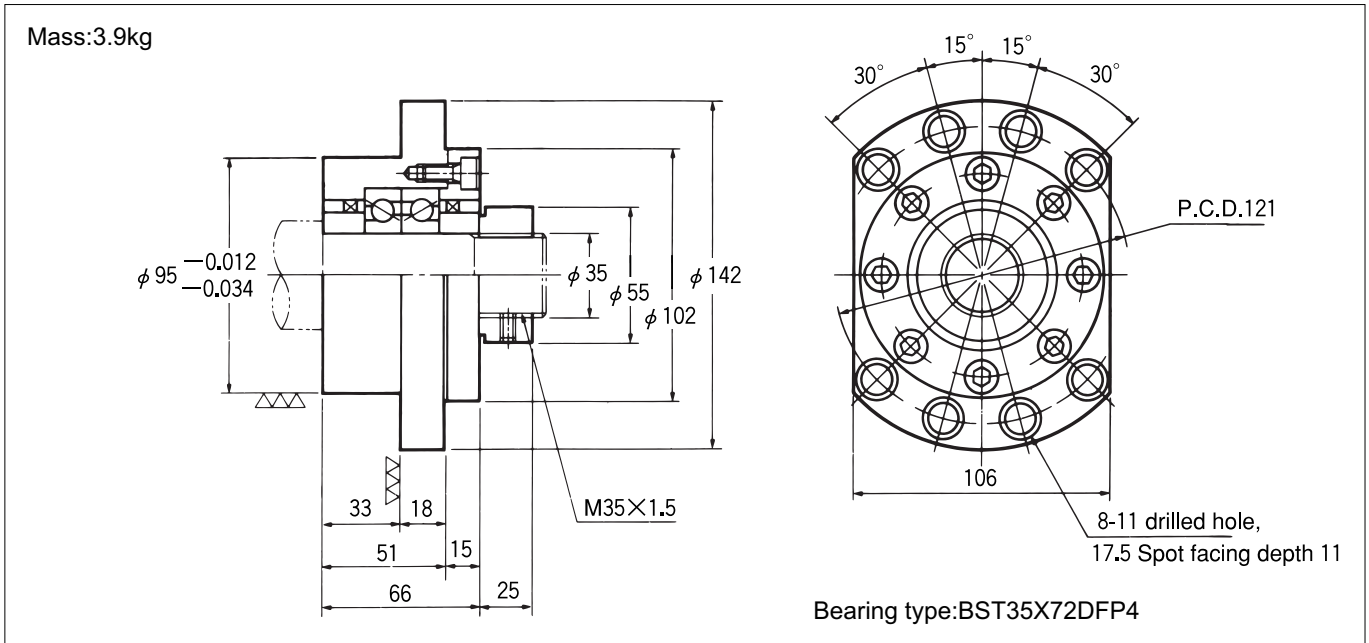

Support unit for machine tools/BUT-40

(Unit:mm)

