

BALL SCREWS AND BALLSCREW ACTUATOR

GUIDE BOOK



KURODA BALL SCREWS

Compact and High Speed!!

Standard Ground Ball Screw H series

HG : C5 Accuracy
End Cap Method with Multi-Start Threads
High Speed Application
Shaft : $\phi 6 - \phi 32$

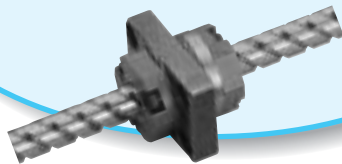

Page 7

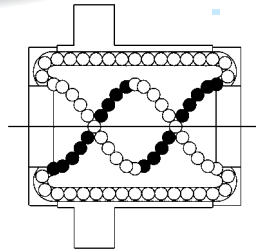

Standard Ground Ball Screw D series

DP : C3 Accuracy
Deflector Method
Compact Nut Diameter
Shaft : $\phi 6 - \phi 14$



Page 6

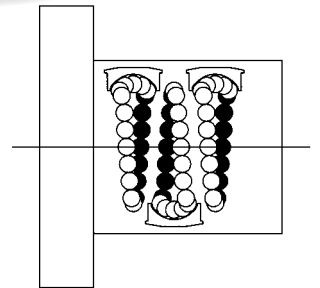

High-Speed and Ultra-Quiet Ball Screw F Series

Innovative End Deflector Method
Ultra Quiet and MAX.5000r.p.m. (in $\phi 25$ screw shaft)
 $\phi 20$ & 25 in C5 & C7 as standard
 $\phi 20-40$ in C3 & C5 as customized

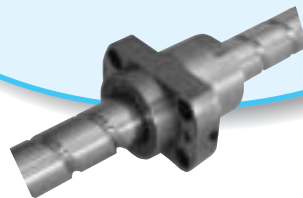

Page 8

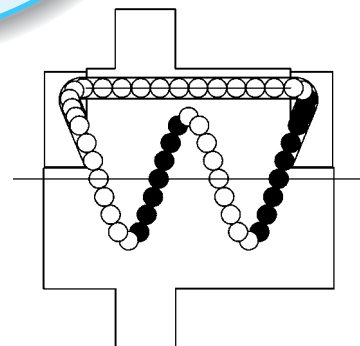

Abundant Variety of Ball Screws

Standard Ground Ball Screw

G series
 GE : C7, GG : C5, GP : C3
 Shaft : $\phi 8 - \phi 32$

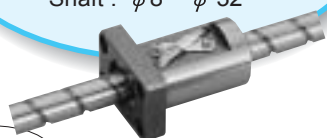

Page 5, 6

Standard Rolled Ball Screw

G series
 GY : C10, GW : C7
 Shaft : $\phi 8 - \phi 40$

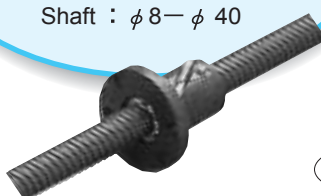

Page 10, 11

Customized Ground Ball Screw

G series
 GR, GD, FR, GM, GZ : C0 - C10
 Shaft : $\phi 8 - \phi 125$



Page 9

Space, Designing & Ass'y time saving

Ballscrew Actuator

SE series
 High Rigidity
 with Rolled Ball Screw
 Ball Screw Dia. : $\phi 8, 10, 15$

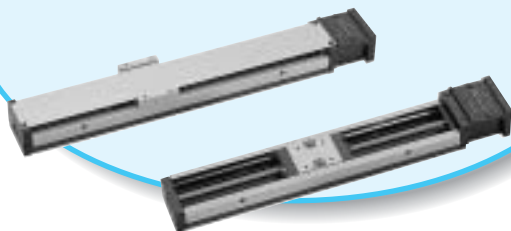

Page 12

Ballscrew Actuator

SG series
 High Accuracy and Rigidity
 with Ground Ball Screw
 Ball Screw Dia. : $\phi 6 - 20$

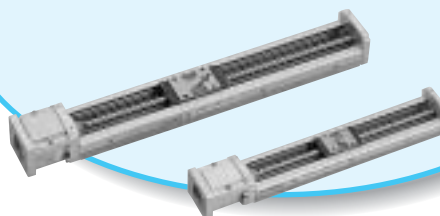

BALL SCREW RANGE

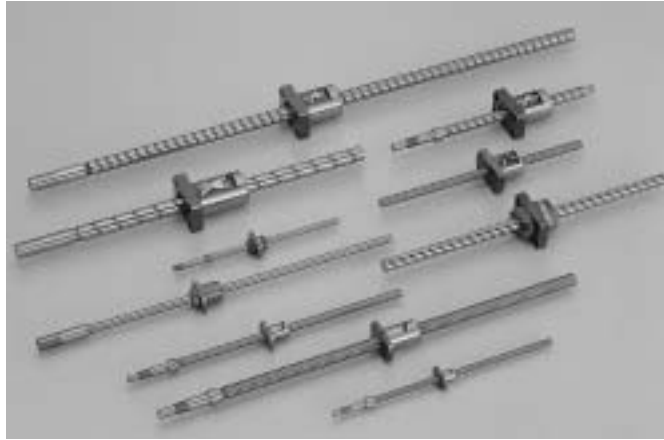

ORDERING NUMBER

● Without end machining

GE 1504DS—BALR—0600A

① ② ③ ④ ⑤ ⑥ ⑦ ⑧ ⑨ ⑩ ⑪

● With end machining

GE 1504DS—BALR—1100 X 0600—C7M

① ② ③ ④ ⑤ ⑥ ⑦ ⑧ ⑨ ⑩ ⑪ ⑫ ⑬ ⑭

① Series

- Ground ball screw
- GE : JIS C7 grade
- GG : JIS C5 grade
- GP : JIS C3 grade
- DP : JIS C3 grade
- HG : JIS C5 grade high lead
- FE : JIS C7 grade
- FG : JIS C5 grade
- FR : Order for nut with exact same dimensions as our catalogue
- GR : Order for nut with exact same dimensions as our catalogue
- GD : Order for nut with exact same dimensions as our catalogue
- GM : Order for nut with different flange dimensions from our catalog
- GZ : Customized ball screw
- Rolled ball screw
- GY : JIS C10 grade
- GW : JIS C7 grade
- GT : Customized for Rolled Ball Screw

② Shaft diameter (mm)

③ Lead (mm)

④ Number of circuits

- A : 1.5 turns 1 circuit
- B : 1.5 turns 2 circuits
- C : 1.5 turns 3 circuits
- D : 2.5 turns 1 circuit
- E : 2.5 turns 2 circuits
- F : 2.5 turns 3 circuits
- G : 3.5 turns 1 circuit
- R : 3.5 turns 2 circuits
- H : 1 turn 2 circuits
- J : 1 turn 3 circuits
- K : 1 turn 4 circuits
- L : 1 turn 5 circuits
- M : 1 turn 6 circuits
- Q : End cap type
- Z : Customized (including shaft only)
- P : End deflector type

⑤ Nut type

- A : Single nut
- T : Integral nut
- D : Double nut (Pin type)
- Z : Customized (including shaft only)

⑥ Flange type

- A~E, H
- N : Without flange
- Z : Customized (including shaft only)

⑦ Ball return system

- A : Tube method (Round type)
- T : Tube method (Standard type)
- U : Tube method (Inlaid type)
- K : Tube method (Square type)
- D : Deflector method
- G : Guide plate method
- E : End cap method
- Z : Customized (including shaft only)
- P : End deflector method

⑧ Wiper material

- P : Plastic
- L : Lip seal
- F : Felt
- B : Brush
- S : LUBSEAL
- N : No wiper

⑨ Thread direction

- R : Right hand thread
- L : Left hand thread
- Z : Others (including shaft only)

⑩ Overall length of screw shaft (mm)

- ⑪ Shaft end configuration
- A : Without end machining
- B : One shaft end machining as per your drawing
- X : End machining as per your drawing
- Y : End machining as per your drawing for rolled screw shaft

⑫ Thread length (mm)

- ⑬ Accuracy grade
- C0, C1, C2, C3, C4, C5, C7, CA(=C10)

⑭ Axial clearance

- S : 0 (Preloaded)
- F : 0.005mm max
- H : 0.010mm max.
- M : 0.030mm max
- L : 0.200mm max
- Y : Axial play for rolled ball screw
- Z : Others

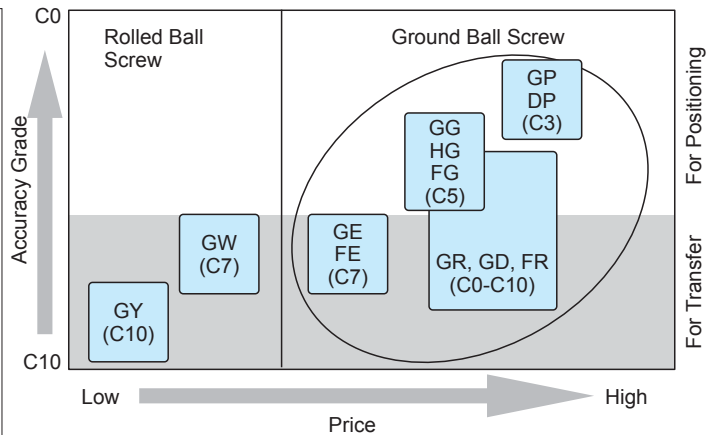

— MATERIAL & HARDENING — GROUND BALL SCREW

	MATERIAL	HEAT TREATMENT	HARDNESS
NUT	SCM420	Carburizing	58-62HRC
SHAFT	SCM415 SCM420	Carburizing	58-62HRC
	AISI4150HV	Induction hardening	58-62HRC
STEEL BALL	SUJ2	Hardening	60HRC or higher

ROLLED BALL SCREW

	MATERIAL	HEAT TREATMENT	HARDNESS
NUT	SCM420	Carburizing	56-62HRC
SHAFT	S45C S55C	Induction hardening	58-62HRC
STEEL BALL	SUJ2	Hardening	60HRC or higher

Screw Shaft Dia. & Lead Combination Standard Ball Screw (For Transfer)

		Lead (mm)																		
		1.5	2	2.5	4	5	6	8	10	15	16	20	25	32	40					
Screw shaft dia. (mm)	8	E	E YW		E Y	Y		Y												
	10		E Y	E YW	E YW	Y			E YW _y											
	12		E	E	E YW	E		Y	E YW _y			E								
	15		E		E	E YW			E YW _y	E		YW	E YW							
	16											E						YW		
	20				E	E YW			E YW				E YW _y						YW	
	25					E YW _y			E YW				E	E YW _y						
	28							Y												
	32					E			E Y										Y	
	36														Y					
	40													Y						Y

GE series:E GY series:Y GW series:W
FE series:F GY high load series:y

Standard Ball Screw (For Positioning)

		Lead (mm)																			
		1	1.5	2	2.5	3	4	5	6	10	12	15	16	20	25	30	32	40	50	60	64
Screw shaft dia. (mm)	φ6	D						H													
	φ8	D	G P	G PD			G			H											
	φ10			G PD	G P		G			G											
	φ12			G PD		D	G P	G P		G				G		H					
	φ14						D														
	φ15			G P			G P	G P		G		G		G H	H			H			
	φ16												G				H				
	φ20						G P	G P		G F				G F H		H		H		H	
	φ25							G F		G F				G	G F H				H		
	φ32							G		G											H

GG series:G GP series:P HG series:H
FG series:F DP series:D

D Series - Deflector Method/G Series - Tube Method DP(C3 Accuracy)/GP(C3 Accuracy)

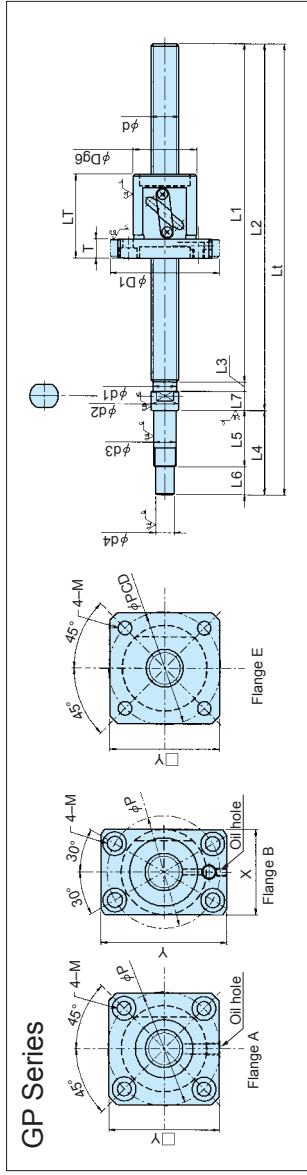
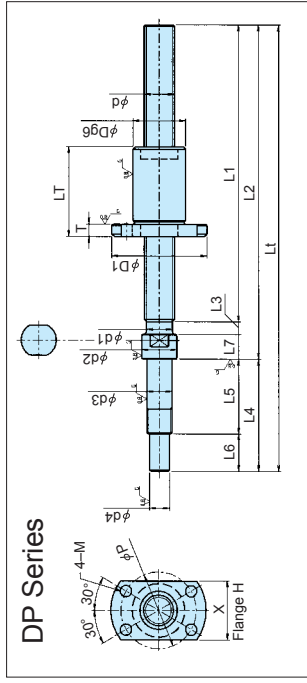

DP Series

Model No.	Shaft dia. d	Lead	Root dia. d1	Circuit & Turn	Axial clearance	Basic Load Rating (N/C)	Dynamic Load Rating (N/C)	Basic Static Load Rating (N/C)	Shaft Dimensions										Nut Dimensions										Oil Hole	
									Shoulder		L1	L2	L3	L4	L5	d3	L6	d4	Nut			Flange			Screw	Flange	Wiper			
									d2	L7									D	L _T	T	D1	Y	X				P		
DP0601JS-HDNR-0130B-C3F/S	6	1	—	1X3		550	1150	9.5	7	90	100	130	3	30	22.5	6	7.5	4.5	10	14.5	3.5	22	—	14	16	M3	H	N	N/A	
DP0601JS-HDNR-0210B-C3F/S	6	1	—	1X3		650	1600	12	8	132	143	180	3	37	27	8	10	6	12	15	4	25	—	16	19	M3	H	N	N/A	
DP0801JS-HDNR-0260B-C3F/S	8	2	7	1X3		1350	2300	12	8	212	223	260	3	37	27	8	10	6	14	21	4	27	—	17	21	M3	H	N	N/A	
DP0802JS-HDNR-0180B-C3F/S	8	2	7	1X3	F/S	1550	3000	12	8	172	183	220	3	37	27	8	10	6	16	22	5	33	—	21	25	M4	H	N	N/A	
DP1002JS-HDNR-0220B-C3F/S	10	2	9	1X3		1650	3600	14	10	242	255	300	3	45	30	10	15	8	18	22	5	35	—	22	27	M4	H	N	N/A	
DP1202JS-HDNR-0300B-C3F/S	12	3	10.3	1X3		3450	6100	15	10	340	355	400	5	60	40	15	20	10	21	36	5	38	—	23	30	M4	H	P	N/A	
DP1203JS-HDPR-0300B-C3F/S	12	3	10.3	1X3		4600	8600	15	10	470	485	530	5	60	40	15	20	10	26	40	10	45	—	29	35	M4	H	P	N/A	
DP1404JS-HDPR-0530B-C3F/S	14	4	12.1	1X3																										

Asterisked () model No. has the following shaft overall length (Lt) in addition 530mm: 230, 280, 330 and 430mm.

GP Series

</

H Series-End Cap Method HG(C5 Accuracy) For High Speed Application

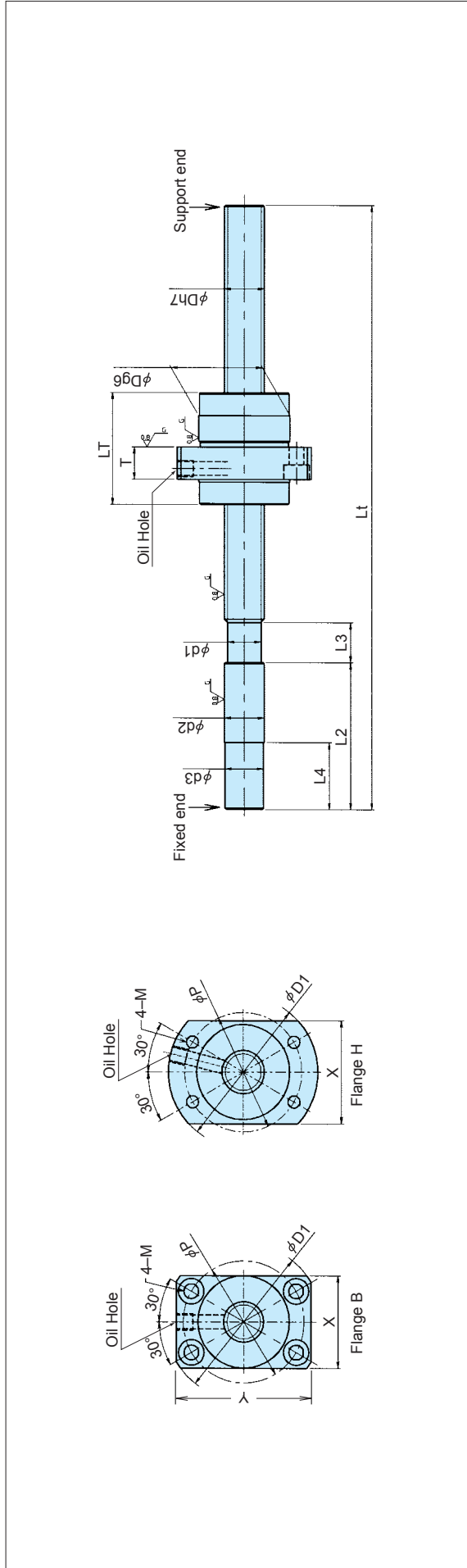

Model No.	Shaft dia. d	Lead	Root dia. d1	Circuit & Turn	Axial clearance	Basic Dynamic Load Rating (N)	Basic Static Load Rating (N/Co)	Shaft Dimensions						Nut Dimensions										Oil hole	
								d2	d3	L4	L2	L3	Lt	Flange			Nut			Flange					Wiper
														T	D1	Y	X	P	PCD	Screw	Flange				
HG0606QS-HEZR-□□□□A	6	6	—	1.5 X2	H	760	1140	9.2	18	40	8	210	14	16.5	4	27	17	21	M3	H	Z	N/A			
HG0812QS-HEZR-□□□□A	8	12	—	1.67 X2	H	2490	3460	12	20	45	12	340	18	27	4	31	20	25	M3	H	Z				
HG1230QS-BEZR-□□□□A	12	30	9.5	0.67 X3	H	4800	6650	12	20	55	15	500,800	32	35	10	56	48	43	M5	B	Z				
HG1520QS-HEZR-□□□□A	15	20	12.5	1.67 X2	F	8740	17550	15	25	55	10	600,1100,1500	34	32	10	55	55	45	M5	H	Z				
HG1525QS-HEZR-□□□□A	15	25	12.5	0.67 X4	F	7220	14050	15	25	55	15	600,1100	34	32	12	58	50	45	M5	B	Z				
HG1540QS-BEZR-□□□□A	15	40	13.5	0.67 X3	H	5600	8600	16	25	55	15	600,1100,1500	35	36.3	10	56	56	44	M4	H	Z				
HG1632QS-HEZR-□□□□A	16	32	13.5	0.67 X3	F	6100	9100	16	25	55	15	600,1100,1500	35	36.3	10	56	56	44	M4	H	Z				
HG2020QS-HEZR-□□□□A	20	20	17.5	1.67 X2	F	18280	36000	20	25	75	5	1000,1500	39	64	10	62	39	50	M5	H	Z	M6			
HG2030QS-HEZR-□□□□A	20	30	17.5	0.67 X3	F	10690	23330	20	25	75	15	1000,1500	40	44.7	12	56	44	40	M5	B	Z				
HG2040QS-HEZR-□□□□A	20	40	17.5	0.67 X3	H	6800	12100	20	25	100	20	1000,1500,2000	47	57.6	10	74	47	60	M6	H	Z				
HG2060QS-BEZR-□□□□A	25	60	21.6	1.67 X4	F	29220	72010	25	25	100	15	1015,1715,2015	50	71	12	76	54	62	M6	H	F				
HG2525QS-HEZR-□□□□A	25	50	22.2	0.67 X3	F	10200	19300	25	25	120	15	1200,1700,2200	60	85	15	94	66	76	M8	H	F				
HG2550QS-HEFR-□□□□A	25	64	21.6	0.67 X3	F	17200	31900	32	25	120	15	1200,1700,2200	60	85	15	94	66	76	M8	H	F				

Model No. □□□□: Overall length Axial clearance H:0.010mm F:0.005mm Wiper material Z:Lip of end cap serves as a wiper F:Felt N/A:Not applicable

Customized Ground Ball Screws

GR/GD/FR

Standard ground ball screws "GR Series (tube method)", "GD Series (deflector method)" and "FR Series (end deflector method)" are standardized, and lineups of various nut types are also available.



COMBINATION OF ACCURACY AND AXIAL CLEARANCE

- Single nut, Preloaded:C0S-C5S
- Single nut, Axial clearance 0.005mm or less:C1F-C5F
- Single nut, Axial clearance 0.030mm or less:C4M,C5M, C7M
- Single nut, Axial clearance 0.20mm or less:C7L,C10L
- Double nut, Preloaded:C0S-C5S
- Integral nut, Preloaded:C0S-C5S

●Single Nut Preloaded

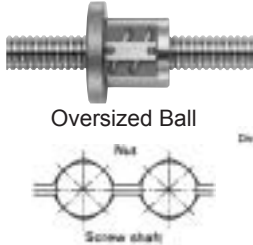

●Double Nut Preloaded

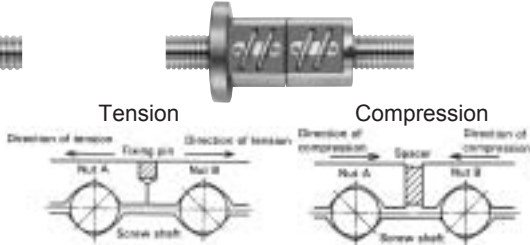

●Integral Nut Preloaded

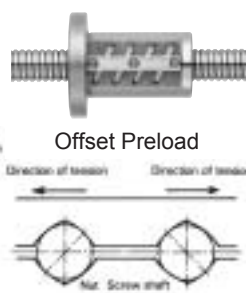

●Others

Contact KURODA for any customized Ball screw as below.
Stainless steel ball screw.
Right and left handed ball screw.
Surface treatment.
Special grease,
and so on

●Accuracy Grade And Manufacturable Length of Screw Shaft

Accuracy grade	Length of Screw shaft								
	C0	C1	C2	C3	C4	C5	C7	C10	
Screw shaft Dia. (mm)	φ5	90	120	120	140	140	140	—	—
	φ6	160	180	180	210	210	210	—	—
	φ8	240	280	280	340	340	340	340	—
	φ10	340	400	400	480	480	500	500	—
	φ12	420	500	500	600	600	700	700	—
	φ15	500	600	600	700	800	1500	1500	1500
	φ16	500	600	600	700	800	1500	1500	1500
	φ20	800	900	1100	1400	1400	1600	1800	1800
	φ25	1100	1300	1600	1800	1800	2000	2300	2300
	φ28	1200	1500	1800	2000	2000	2200	2600	2600
	φ32	1600	1800	2200	2500	2500	2800	3200	3600
	φ36	1800	2000	2500	2800	2800	3100	3600	4000
	φ40	2000	2200	2800	3200	3200	3600	4600	4600
	φ45	2000	2300	3000	3600	3600	4100	5000	5200
	φ50	2000	2800	3600	4000	4000	4500	5700	5700
	φ55	2000	3000	4000	5000	5000	5700	5700	5700
	φ63	2000	3000	4500	5200	5200	5700	5700	5700
φ70	—	3000	4500	5500	5500	5700	5700	5700	
φ80	—	3000	4500	5500	5500	5700	5700	5700	
φ100	—	3000	4500	5500	5500	5700	5700	5700	
φ125	—	3000	4500	5500	5500	5700	5700	5700	

When the lead is larger than the screw shaft diameter, the manufacturable accuracy grade is C2-C10.

●Screw Shaft Dia. & Lead Combination

Screw shaft Dia. (mm)	Lead(mm)																			
	1	1.5	2	2.5	3	4	5	6	8	10	12	15	16	20	24	25	32	40	50	
5	○																			
6	*		*				*	*												
8	△	○	○	○	○	○	*	○	○											
10	*	○	○	○	○	○	○	*	*	○			*							
12		○	○	○	○	○	○	○	*	*				○						
14			*		*	*	*	*	*	*										
15			○	○	○	○	○	○	○	○		*	○	○						○
16			*		*		○	○	○	*			○	*						
20			*	○	*	*	○	○	*	○	*		*							○
25			*	*	*	*	○	○	*	○	*	*	*	*						○
28				*	*	*	○	○	*	○	*	*	*	*						○
32				*	*	*	○	○	*	○	*	*	*	*						○
36					*	*	○	○	*	○	*	*	*	*						○
40					*	*	○	○	*	○	*	*	*	*						○
45					*	*	○	○	*	○	*	*	*	*						○
50					*	*	○	○	*	○	*	*	*	*						○
55					*	*	○	○	*	○	*	*	*	*						○
63					*	*	○	○	*	○	*	*	*	*						○
70					*	*	○	○	*	○	*	*	*	*						○
80					*	*	○	○	*	○	*	*	*	*						○
100					*	*	○	○	*	○	*	*	*	*						○
125					*	*	○	○	*	○	*	*	*	*						○

○:GR series(Single nut) ●:GR series(Integral nut) ◎:GR series(Double nut)
 △:GD series(Single nut) ▼:GD series(Integral nut) ◇:FR series(Single nut) * :Made to order

①:Tube method, Single nut ④:Deflector method, Single nut
 ②:Tube method, Double nut ⑤:Deflector method, Integral nut
 ③:Tube method, Integral nut ⑥:End deflector method, Single nut

G Series - Rolled Ball Screw GW(C7 Accuracy)/GY(C10 Accuracy)

Contact KURODA for No-backlash rolled ball screw.

For more detailed dimensions of shaft and nut, please refer to our Ball Screw Catalogue or visit our web site at «www.kuroda-precision.com».

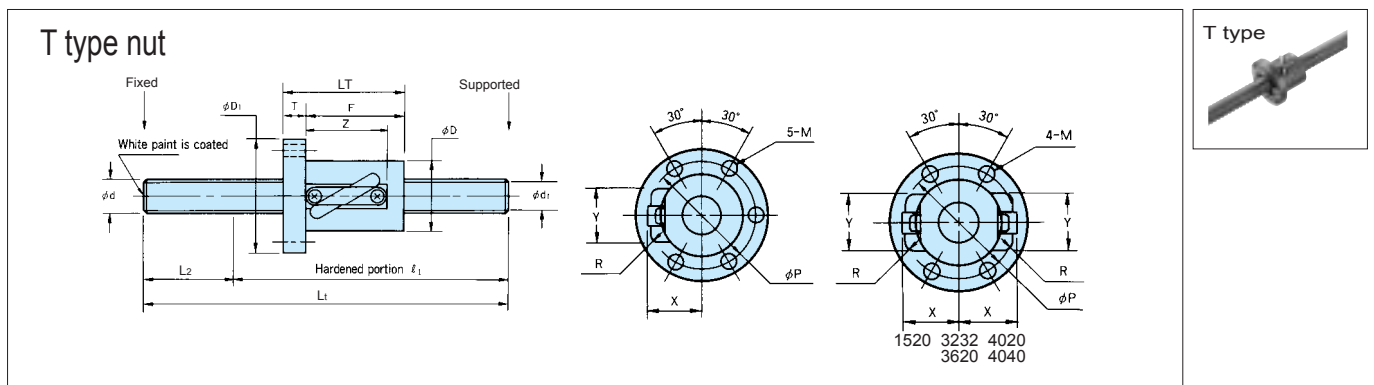
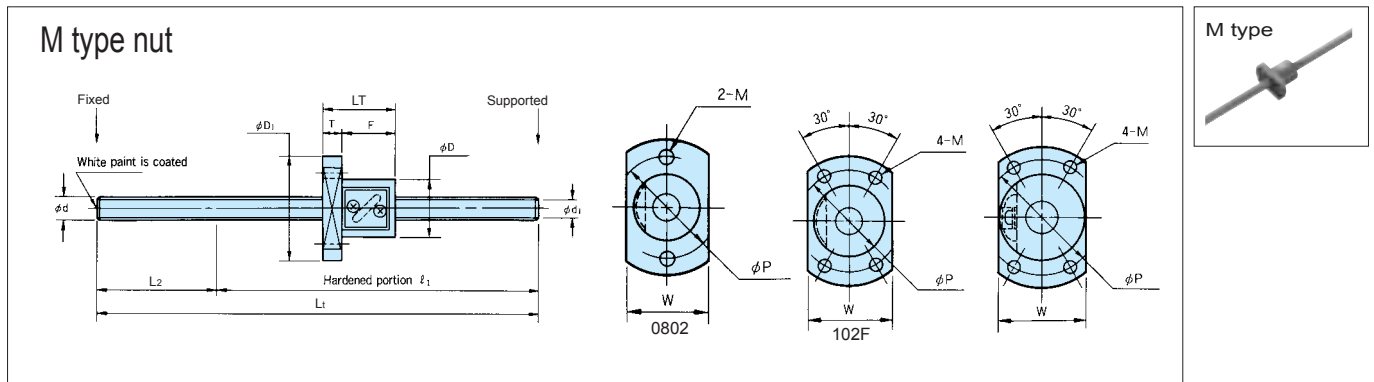

M NUT

(Unit:mm)

Model No.	Shaft dia. d	Lead	Root dia. d1	Circuits & Turns	Basic Dynamic Load Rating (N) C	Basic Static Load Rating (N) C0	Shaft Dimensions		
							Overall Length Lt	L2	
GW/ GY 0802GS - HGNR - □□□□ A	8	2	6.6	3.5×1	1800	3200	200,400	55	
GY 0804DS - HANR - □□□□ A		4	6.3	2.5×1	1900	3100			
GY 0808DS - HANR - □□□□ A		8			1200	1800			
GY 1002DS - HANR - □□□□ A	10	2	8.4	2.5×1	1700	3000	400,600	60	
GW/ GY 102FGS - HGNR - □□□□ A		2.5	8.2	3.5×1	2600	5200			
GW/ GY 1004DS - HANR - □□□□ A		4	7.8	2.5×1	2300	4800			
GW/ GY 1010AS - HANR - □□□□ A		10			1.5×1	1850			3200
GY 1010BS - HANR - □□□□ A		10			1.5×2	3360			6400
GW/ GY 1204DS - HANR - □□□□ A	12	4	10	2.5×1	2600	5800	400,800		
GY 1208DS - HANR - □□□□ A		8			3800	6700			

Model No. □□□□ : Overall length Wiper material N: No wiper

T NUT

(Unit:mm)

Model No.	Shaft dia. d	Lead	Root dia. d1	Circuits & Turns	Basic Dynamic Load Rating (N) C	Basic Static Load Rating (N) C0	Shaft Dimensions			
							Overall Length Lt	L2		
GY 1505DS - CT*R - □□□□ A	15	5	12.5	2.5×1	5100	10500	600,1200	60		
GY 1510DS - CT*R - □□□□ A		10			5100	10500				
GY 1520BS - CT*R - □□□□ A		20		5800	13300					
GY 2005DS - CT*R - □□□□ A	20	5	17.5	2.5×1	6200	14700	600,1200,2000	80		
GY 2010DS - CT*R - □□□□ A		10			10600	22700				
GY 2020DS - CT*R - □□□□ A		20			6200	14700				
GY 2505DS - CT*R - □□□□ A	25	5	21.8	2.5×1	11900	37300	1000,2000,2500	110		
GY 2510ES - CT*R - □□□□ A		10			20.3	2.5×2			27500	76300
GY 2525DS - CT*R - □□□□ A		25			21.5	2.5×1			9300	22700
GY 2806ES - CTBR - □□□□ A	28	6	25.6	2.5×2	12100	42300	1000,2000,3000			
GY 3210ES - CTBR - □□□□ A		10			27.2	2.5×1			32800	86700
GY 3232BS - CTBR - □□□□ A	32	32	27.8	1.5×2	14600	38900	1000,2000,3000			
GY 3610ES - CTBR - □□□□ A		10			31.1	2.5×2			35100	98200
GY 3620ES - CTBR - □□□□ A	36	20	35100	98200			1000,2000,3000			
GY 4010RS - CTBR - □□□□ A		40	10	35.1	3.5×2	49600			153700	2000,3000,4000
GY 4020ES - CTBR - □□□□ A	20		2.5×2			37100	105600			
GY 4040BS - CTBR - □□□□ A	40		1.5×2			23900	66900			

Model No. □□□□ : Overall length Wiper material N: No wiper L: Lip seal B: Brush S: LUBSEAL *: Please select L or S when your order.

G Series - Rolled Ball Screw GW(C7 Accuracy)/GY(C10 Accuracy)

Contact KURODA for Preloaded rolled ball screw.

For more detailed dimensions of shaft and nut, please refer to our Ball Screw Catalogue or visit our web site at «www.kuroda-precision.com».

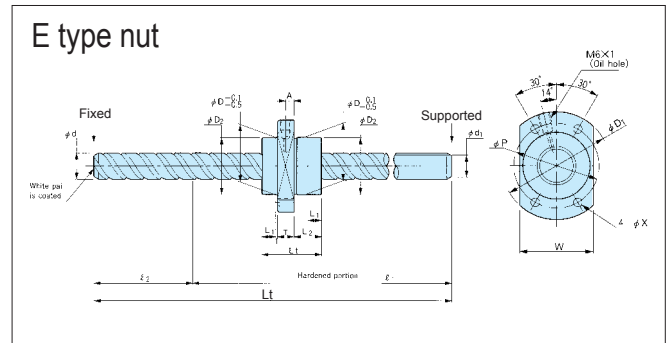
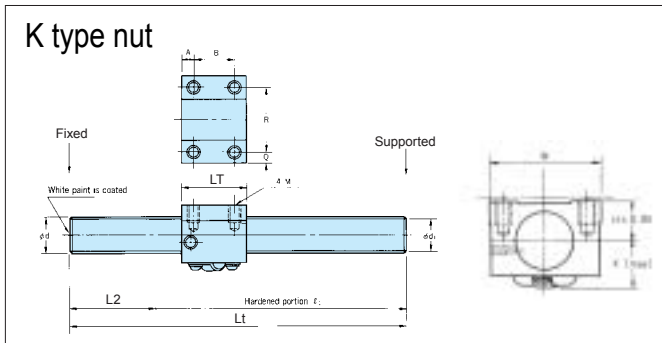
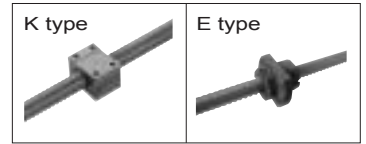
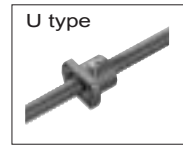
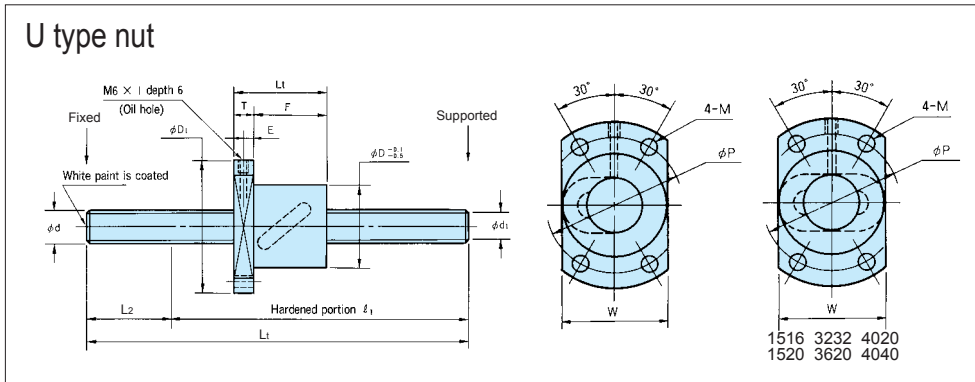

U NUT

(Unit:mm)

Model No.	Shaft dia. d	Lead	Root dia. d1	Circuits & Turns	Basic Dynamic Load Rating (N) C	Basic Static Load Rating (N) C0	Shaft Dimensions	
							Overall Length Lt	L2
NEW GY 0805DS - HUNR - □□□□ A	8	5	6.4	2.5×1	1900	3100	200,400	55
NEW GW/ GY 1004DS - HUNR - □□□□ A	10	4	7.7	2.5×1	2300	4800	400,600	60
NEW GY 1005DS - HUNR - □□□□ A		5			2300	4800		
NEW GY 1208DS - HULR - □□□□ A	12	8	10	2.5×1	3800	6700	400,800	60
NEW GW/ GY 1210AS - HULR - □□□□ A		10	9.6	1.5×1	2850	4950		
NEW GY 1210BS - HULR - □□□□ A				1.5×2	5170	9900		
NEW GW/ GY 1505DS - HU*R - □□□□ A	15	6	12.5	2.5×1	5100	10500	600,1200	60
NEW GW/ GY 1510DS - HU*R - □□□□ A		10				5100		
NEW GY 1510ES - HU*R - □□□□ A				2.5×2	9250	21000		
NEW GW/ GY 1516BS - HULR - □□□□ A		16	12.7	1.5×2	4300	10200	600,1200,2000	80
NEW GW/ GY 1520BS - HU*R - □□□□ A		20	12.5		5800	13300		
NEW GW/ GY 2005DS - HU*R - □□□□ A	20	5	17.5	2.5×1	6200	14700	600,1200,2000	80
NEW GW/ GY 2010DS - HU*R - □□□□ A		10	16.3		10600	22700		
NEW GW/ GY 2020DS - HU*R - □□□□ A		20	17.5	6200	14700			
NEW GY 2020ES - HU*R - □□□□ A				2.5×2	11250	29400		
NEW GW/ GY 2505DS - HU*R - □□□□ A	25	5	21.8	2.5×1	11900	37300	1000,2000,2500	110
NEW GY 2505ES - HU*R - □□□□ A					2.5×2	21600		
NEW GW/ GY 2510ES - HU*R - □□□□ A		10	20.3	2.5×2	27500	76300		
NEW GW/ GY 2525DS - HU*R - □□□□ A		25	21.5	2.5×1	9300	22700		
NEW GY 2525ES - HU*R - □□□□ A				2.5×2	16880	45400		
NEW GY 2806ES - HUBR - □□□□ A	28	6	25.6	2.5×2	12100	42300	1000,2000,3000	150
NEW GY 3210ES - HUBR - □□□□ A	32	10	27.2	2.5×1	32800	86700	1000,2000,3000	
NEW GY 3232BS - HUBR - □□□□ A		32	27.8	1.5×2	14600	38900	1000,2000,3000	200
NEW GY 3610ES - HUBR - □□□□ A	36	10	31.1	2.5×2	35100	98200	1000,2000,3000	
NEW GY 3620ES - HUBR - □□□□ A		20			35100	98200		
NEW GY 4010ES - HUBR - □□□□ A	40	10	35.1	2.5×2	37100	105600	2000,3000,4000	
NEW GY 4020ES - HUBR - □□□□ A		20			37100	105600		
NEW GY 4040BS - HUBR - □□□□ A		40		1.5×2	23900	66900		

Model No.□□□□:Overall length W:Wiper material N:No wiper L:Lip seal B:Brush S:LUBSEAL *:Please select L or S when your order.

E NUT

(Unit:mm)

Model No.	Shaft dia. d	Lead	Root dia. d1	Circuits & Turns	Basic Dynamic Load Rating (N) C	Basic Static Load Rating (N) C0	Shaft Dimensions	
							Overall Length Lt	L2
GW/ GY 1632QS - HEZR - □□□□ A	16	32	13.5	0.67×3	4200	7700	600,1200	60
GW/ GY 2040QS - HEZR - □□□□ A	20	40	17.5		4700	10300	600,1200,2000	80

Model No.□□□□:Overall length W:Wiper material Z:Lip of end cap serves as a wiper.

K NUT

(Unit:mm)

Model No.	Shaft dia. d	Lead	Root dia. d1	Circuits & Turns	Basic Dynamic Load Rating (N) C	Basic Static Load Rating (N) C0	Shaft Dimensions	
							Overall Length Lt	L2
GW/ GY 1505DS - NKLR - □□□□ A	15	5	12.5	2.5×1	5100	10500	600,1200	60
GW/ GY 1510DS - NKLR - □□□□ A		10			5100	10500		
GW/ GY 2005DS - NKLR - □□□□ A	20	5	17.5	2.5×1	6200	14700	600,1200,2000	80
GW/ GY 2010DS - NKLR - □□□□ A		10			16.3	10600		
GW/ GY 2505DS - NKLR - □□□□ A	25	5	21.8	2.5×1	6600	18700	1000,2000,2500	110
GW/ GY 2510ES - NKLR - □□□□ A		10			20.3	27500		
GW/ GY 3210ES - NKBR - □□□□ A	32	10	27.2	2.5×2	32800	86700	1000,2000,3000	150

Model No.□□□□:Overall length W:Wiper material L:Lip seal B:Brush

Linear Guide & Ballscrew Integrated Actuator

High accuracy, rigidity and compactness
Most suitable positioning unit can be configured according to applications.

- Type of ball screw : High and Precision in Accuracy grade
- Width of guide rail :
SG Series : 40, 50, 60, 86 and 100mm
SE Series : 50.5, 60.5 and 86.5mm
- Table Height :
SG Series : 20, 26, 33, 46 and 55mm
SE Series : 23, 30 and 45mm
- Types of Slide Block : Short Block & Long Block
- Quantity of Slide Block : 1 or 2
- Intermediate Flanges For Different Motor Brackets Available
- Dustproof Cover And Sensor Available (Option)
- Multi-points Precise Positioning
- Excellent Repeatability

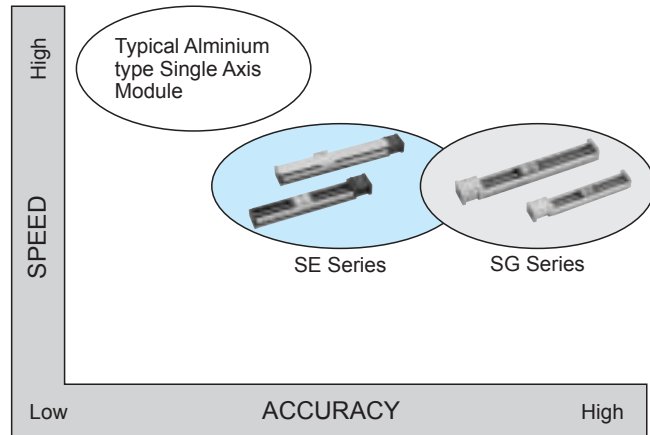
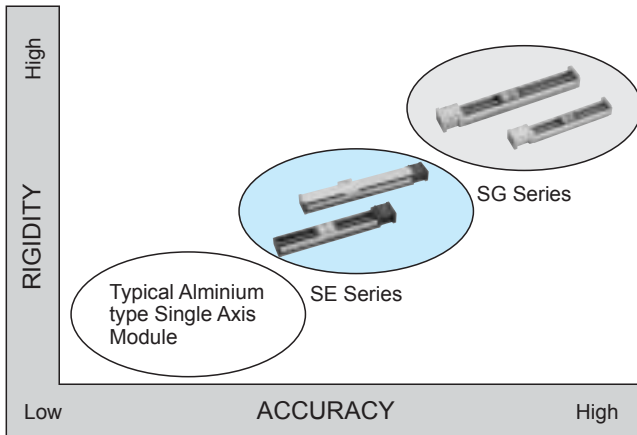

SG Series

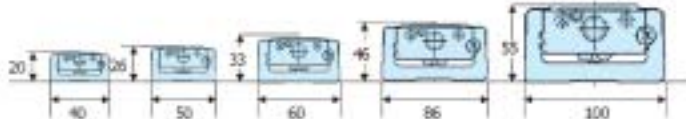

SE Series

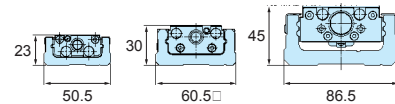

SG33 05 A—150 P—A1 C C—L C—PS

- ① ② ③ ④ ⑤ ⑥ ⑦ ⑧ ⑨ ⑩ ⑪

① Product Series
SG20, SG26, SG33, SG46, SG55
SE23, SE30

② Lead of Ball Screw

	Lead	SG20	SG26	SG33	SG46	SG55	SE23	SE30	SE45
01	1mm	○	—	—	—	—	—	—	—
02	2mm	—	○	—	—	—	○	—	—
04	4mm	—	—	—	—	—	—	○	—
05	5mm	○	○	○	—	—	○	○	○
10	10mm	—	—	○	○	—	—	○	○
20	20mm	—	—	—	○	○	—	—	○

③ Slide Block

A	With 1 long block
B	With 2 long blocks
C	With 1 short block
D	With 2 short blocks

④ Guide Rail Length (mm)

Series	Guide Rail Length(mm)									
SG20	100	150	200	—	—	—	—	—	—	—
SG26	150	200	250	300	—	—	—	—	—	—
SG33	150	200	300	400	500	*600	—	—	—	—
SG46	340	440	540	640	740	*840	*940	*1040	*1140	*1240
SG55	980	1080	1180	*1280	*1380	—	—	—	—	—
SE23	150	200	250	300	—	—	—	—	—	—
SE30	150	200	300	400	500	600	700	750	—	—
SE45	540	640	740	840	940	—	—	—	—	—

Note) • Asterisk length (*) is compatible with high accuracy-grade items only.
• Consult KURODA for longer guide rail length.

⑤ Ball Screw Accuracy Grade

SG Series

H : High Grade

P : Precision Grade

SE Series

W : Rolled Ball Screw C7 Accuracy Axial play 0.020 or less

U : Rolled Ball Screw C7 Accuracy Preloaded

⑥ Motor Bracket Type

(reference to SG/SE complete catalog for details)

⑦ Dustproof Cover

N : Without dustproof cover

C : With dustproof cover

⑧ Sensor

N : Without sensor

S : With photo-micro sensor

K : With proximity sensor

C : With photo-micro sensor

H : With photo-micro sensor

⑨ Anti corrosive black coating

N : Without coating

L : Anti corrosive black coating

⑩ Grease

N : ALVANIA grease S2 (Standard)

C : C Grease

⑪ Dowel hole

PS : Dowel hole provided.

No symbol : Not provided.

Can be equipped inside of G series nut completely.

- Good for Environment & clean.
- Prolong maintenance service period

For G Series Ball Screw



ORDERING NUMBER

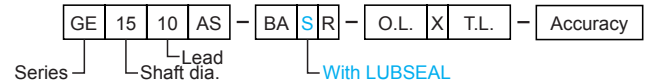

O.L. : Overall Length (mm)
T.L. : Thread Length (mm)

Shaft Dia. (mm)	Lead (mm)	Applicable Series Screws
15	5	GP/GG/GE/GW/GY
	10	GG/GE/GW/GY
	15	GG/GE
	20	GG/GE/GW/GY
20	5	GP/GG/GE/GW/GY
	10	GG/GE/GW/GY
	20	GG/GE/GW/GY
25	5	GG/GE/GW/GY
	10	GG/GE/GW/GY
	20	GG/GE
	25	GG/GE/GW/GY

- Other Shaft Dia. & lead, please consult KURODA.
- Shaft end machining should be made by KURODA.

STRUCTURE

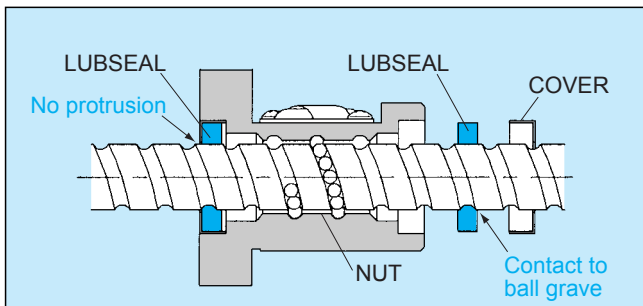

- Slight drag torque increase by LUBSEAL may occur.
- Accuracy, axial clearance, preload, external dimensions are same as standard G series ball screw.

ENDURANCE TEST

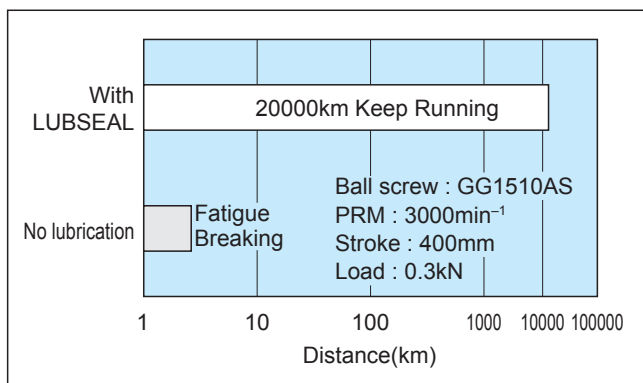

REMARKS

- The same oil as ALVANIA grease S2 which is applied inside the nut is impregnated in LUBSEAL.
- LUBSEAL for any other ball screw excluding G series, please consult KURODA.
- When GY series ball screw is equipped with LUBSEAL, no surface treatment is made on the screw shaft.
- Maximum ambient temperature is 50°C (122°F)
- Organic solvent/kerosene should not be applied.

For F Series Ball Screw



ORDERING NUMBER

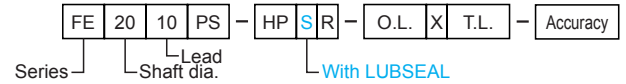

O.L. : Overall Length(mm)
T.L. : Thread Length(mm)

Shaft Dia. (mm)	Lead (mm)	Applicable F Series Ball Screw Number
20	10	FE/FG2010PS-HPSR-****A
	20	FE/FG2020PS-HPSR-****A
25	5	FE/FG2505PS-HPSR-****A
	10	FE/FG2510PS-HPSR-****A
	25	FE/FG2525PS-HPSR-****A

- Other Shaft Dia. & Lead, please consult KURODA.
- Shaft end machining should be made by KURODA.

STRUCTURE

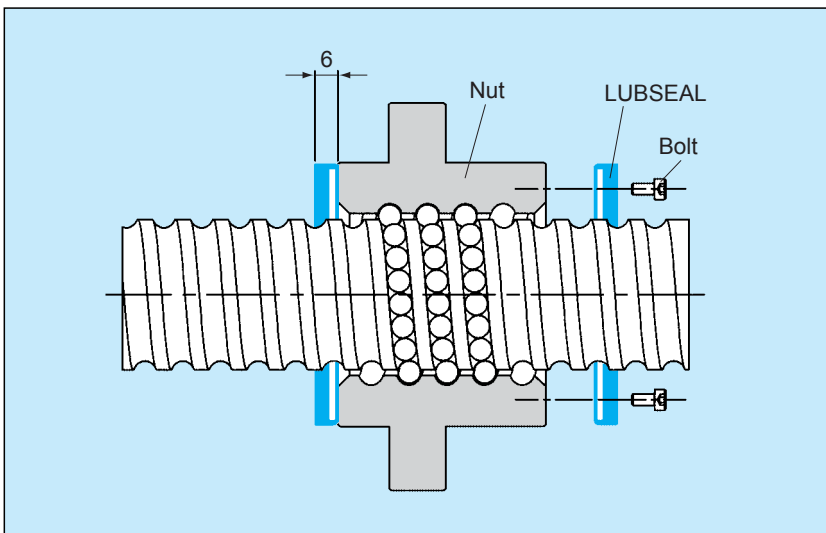

- When F series is equipped with lubrication unit LUBSEAL, overall length of nut is longer than usual by 12mm (6mm on one side). There is no protrusion of bolt head fitted with LUBSEAL.

SUPPORT UNITS / BUK, BUM, BUT

- Applicable to 6–32mm Dia. Ball Screw
- Accurate center height
- Preload adjusted angular bearing DF
(Face-to-Face) combination as standard.
DB(Back-to-Back) combination is also available
on your request when higher rigidity is required.
- Special surface treatment, special grease
etc. consult KURODA.
- Affordable price, Quick Delivery.



ORDERING NUMBER

BUK—10A

① ② ③

① Series

BUK : Direct mount(Rectangle) Support Unit
BUM : Circle Flange Support Unit
BUT : Support unit for machine tool

② Bearing journal diameter(mm)

③ Combination

A : Set of fixed and supported end units

F : Fixed end unit

S : Supported end unit

No mark : Fixed end unit and supported end bearing

BUK Series			BUM Series				BUT Series
Set	Fixed-end unit	Supported-end unit	Set	Fixed-end unit	Supported-end bearing	Supported-end unit	Fixed-end unit
BUK-6	BUK-6	—	BUM-6	BUM-6F	606ZZ	—	—
BUK-8A	BUK-8F	BUK-6S	BUM-8	BUM-8F	606ZZ	BUM-6S	—
BUK-10A	BUK-10F	BUK-8S	BUM-10	BUM-10F	608ZZ	BUM-8S	—
BUK-12A	BUK-12F	BUK-10S	BUM-12	BUM-12F	6000ZZ	BUM-10S	—
BUK-15A	BUK-15F	BUK-15S	BUM-15	BUM-15F	6002ZZ	BUM-15S	—
BUK-20A	BUK-20F	BUK-20S	BUM-20	BUM-20F	6204ZZ	BUM-20S	BUT-20
BUK-25A	BUK-25F	BUK-25S	BUM-25	BUM-25F	6205ZZ	—	BUT-25
—	—	—	—	—	—	—	BUT-30
—	—	—	—	—	—	—	BUT-35
—	—	—	—	—	—	—	BUT-40

C GREASE

Clean Grease for ball screw



50cc 1kg



C1-080G-J (80g)
C1-400G-J (400g)

The superb quality of C GREASE meets the need for cleanliness in the environment of actuators used in semiconductor manufacturing machines and related parts. KURODA "C GREASE" features cleanliness, stable torque characteristics, high lubricating performance and excellent rust-preventive performance not available from usual fluorine grease.

RESIN NUT LEAD SCREW

PY/PW series



- Lower price & more compact than Ball Screw.
- ACCURACY
PY : C10(±0.21mm/300mm)
PW : C7(±0.05mm/300mm)
- MATERIALS
SCREW SHAFT : S45C or SUS303 on your choice.
NUT : ENGINEERING PLASTIC(PPS)
- SHAFT DIA. × LEAD
10×4, 10×10, 12×4, 12×10

KURODA PRECISION INDUSTRIES LTD.

Head Office: 239, Shimohirama, Saiwai-ku, Kawasaki, Kanagawa 212-8560, Japan
Telephone:044-555-3805
Fax:044-555-1479
<http://www.kuroda-precision.co.jp/e-top>

Chicago Office: 505 West Golf Road, Arlington Heights, Illinois 60005 U.S.A.
Telephone:847-228-6473
Fax:847-228-6475

CAT. No. **KB1000-[®]**

Distributors: