

Drill Chuck

Drill Chuck with Locking Function/SLC

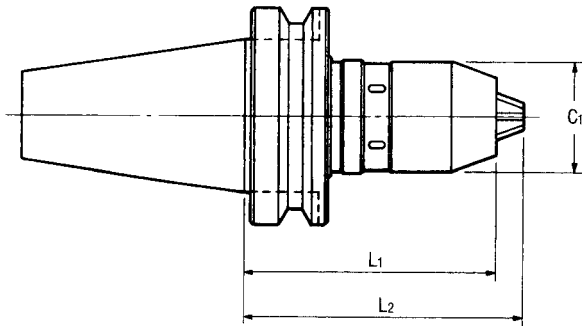

- Due to the utilization of a reverse-rotation locking mechanism, reverse-rotation machining can be carried out.
- Reverse-rotation and release prevention can be implemented in a one-touch operation.
- Machining can be carried out with the same torque in both the forward and reverse directions.
- Tap machining up to M16 is possible.
- Possible to increase the tightening using a hook spanner.



Ordering Instructions

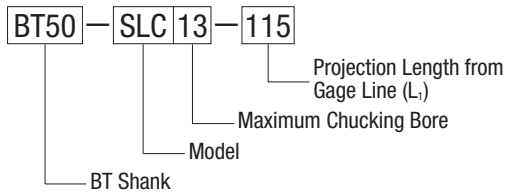

(Unit: mm)

Code No. 283	Model No.	Chucking Bore	C ₁	L ₁	L ₂	Weight (kg)	Included Spanner
888921	BT40-SLC13-105	0.5~13	51	105	118.5	1.9	FS13LC
888922	BT50-SLC13-115	0.5~13	51	115	127.5	4.5	FS13LC

- A hook spanner is included.