

Contents

(Click on desired topic)

D1 High Speed Automation Systems

D3 Gantry Robots



- D5 System One
- D7 System Two
- D9 System Three
- D11 System Four
- D13 System Five
- D15 System Six
- D17 System Seven

D19 Linear Modules Introduction



- D21 HPLA Series Features
- D29 HPLA080 Series Dimensions
- D30 HPLA120 Series Dimensions
- D31 HPLA180 Series Dimensions



-
- D35 BLMA Series Features
 - D39 BLMA Series Dimensions

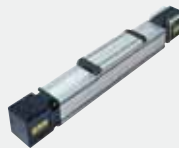

-
- D43 HLE-RB Series Features
 - D50 HLE60-RB Dimensions
 - D51 HLE100-RB Dimensions
 - D52 HLE150-RB Dimensions



-
- D59 HLE-SR Series Features
 - D63 HLE60-SR Dimensions
 - D64 HLE100-SR Dimensions

-
- D69 HLE-Z Series Features
 - D73 HLE-Z150 Dimensions



-
- D75 HZR Series Features
 - D78 HZR Dimensions

Additional Capabilities and Accessories



- D81 HTR Telescopic Vertical Module
 - D82 HDM Rotary Modules
 - D82 ET Rod Style Electric Cylinders
 - D82 Support Structures
 - D83 Motors, Drives, and Controls
 - D84 Limit and Home Sensors
 - D85 Cable Carriers
 - D85 External Bumpers
 - D86 Toe Clamps, T-nuts, T-bolts
 - D86 Splice Plates
-

High Speed Automation

Belt Driven Modules

Gantry Robot Systems and Linear Modules

For high speed automation, both gantry and articulated arm robots are widely used throughout industry. Because of the many inherent advantages of the gantry robot, it is rapidly becoming the preferred choice for:

- palletizing • storage and retrieval
- machine loading • parts transfer
- material handling • automated assembly

Parker offers seven standard gantry configurations to solve these and other automation applications. Utilization of these pre-engineered systems enables the user to redirect scarce engineering resources from motion system design to machine or process functionality.

HPLA and HLE Linear Drive Modules are the primary building blocks for Parker's seven standard gantry systems. With six different cross sectional sizes (60, 80, 100, 120, 150, and 180 mm) and three bearing systems (polyamide or steel rollers, and square rail bearings), these modules can effectively, efficiently and economically satisfy the widest range of application requirements.

Parker Gantry Robot Features

- **Parker minimizes your engineering effort with**
 - Pre-engineered multi-axis systems
 - Drawings, documentation, and sizing
- **Parker is your source for unlimited system solutions**
 - Unrivaled breadth of product
 - Proven design and reliability
 - Optimized mechanics and electronic controls
- **Parker is your assurance of short, reliable lead times**
- **Parker systems are supported by the global Parker network 1-800-C-PARKER**

Gantry Robot CD available at www.parkermotion.com

- Sizing
- Software
- CAD Files (Parametric Tools)
- Product Manuals
- Photos/Applications Library
- Movie Gallery



Gantry Robot Elements

HPLA or HLE Linear Drive Module

Proven high-speed, belt driven linear modules are the core motion components of the gantry system.

Vertical Drive Modules

Designed specifically to satisfy thrust, side, and moment load requirements while providing reliable vertical motion.

Cable Management System

Standardized cable carriers with high flex cables ensure system reliability

Home Position Sensor

Fully adjustable mechanical or proximity sensors provide accurate and repeatable homing.

Travel Limit Sensors

Fully adjustable mechanical or proximity sensors provide over-travel protection.

Gear Reducers

Precision planetary gearheads (in-line and right-angle) accurately transfer motion from the motors and reduce reflected inertia.

Structural Frame

Steel or aluminum support structures are utilized to provide the strength and rigidity needed for high-speed applications.

Servo Motor System

Brushless servo motor system allows closed loop reliability and high dynamic performance.

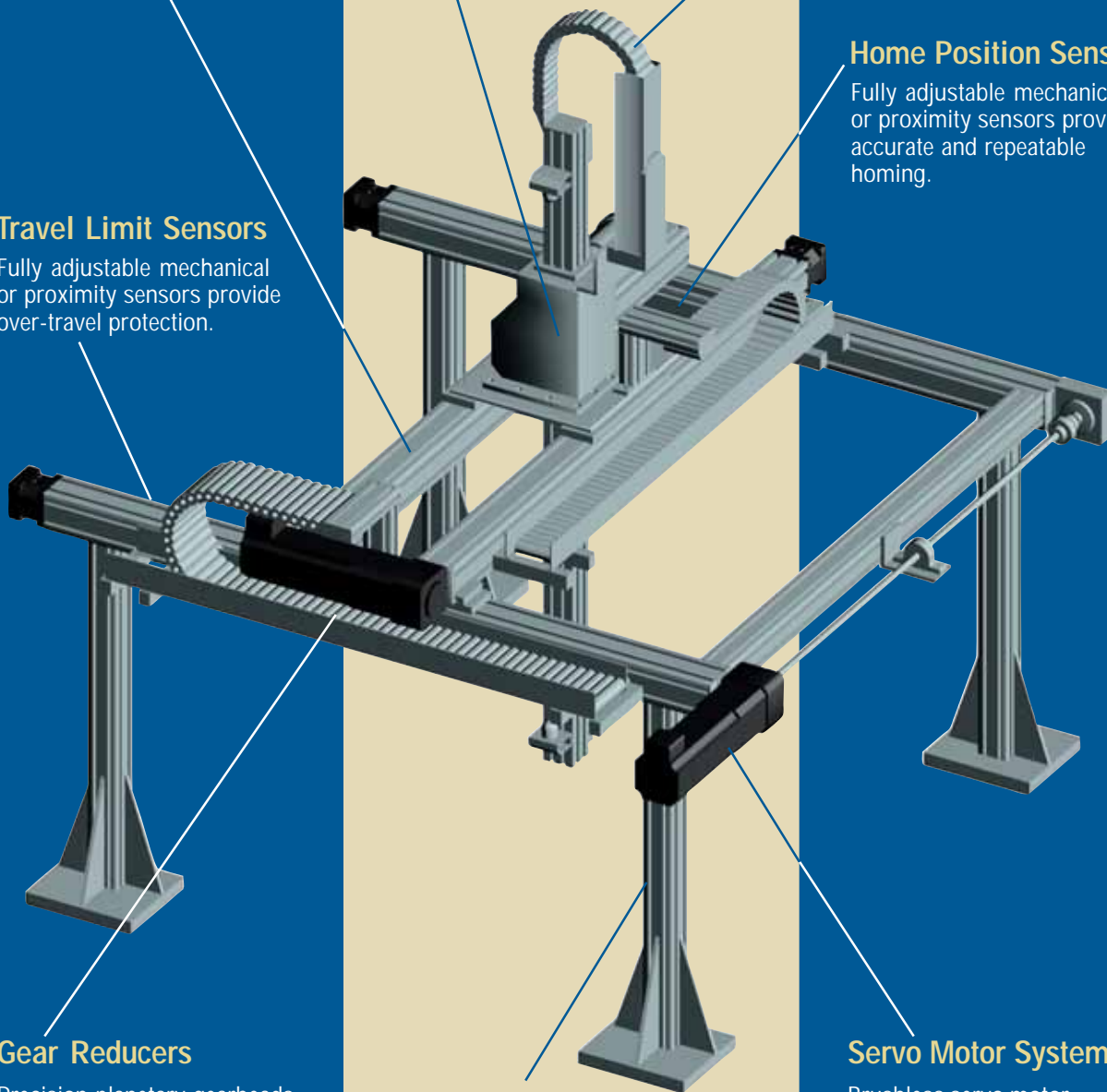

Gantry Robot Configurations

Parker's seven standard system configurations are designed to satisfy the vast majority of gantry robot applications. By standardizing on these configurations, Parker has simplified sizing and selection, shortened lead times, and reduced costs for users of these systems. The travels and loads indicated are nominal, and should not be considered limiting factors. Longer travels and increased loads are attainable depending upon the combination of parameters.



System One
Two Axis: $XX' - Y$



System Two
Two Axis: $XX' - YY'$



System Three
Two Axis: $XX' - Z$

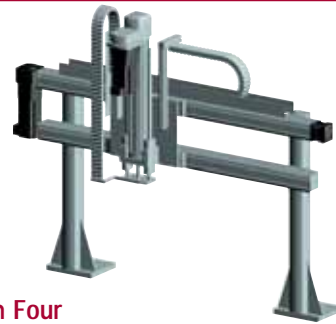

System Four
Two Axis: $XX' - Z$



System Five
Two Axis: $XX' - Z$



System Six
Three Axis: $XX' - YY' - Z$



System Seven
Three Axis: $XX' - YY' - Z$

System One

System One provides two axes of horizontal motion. The primary axis (X) is comprised of two HPLA or HLE Linear Modules linked by a common drive shaft, and the secondary axis (Y) is comprised of one HPLA or HLE Linear Module. These linear modules are capable of high speeds and accelerations over long travels. This system is designed for rapid transport of light to moderate loads in a single horizontal plane.

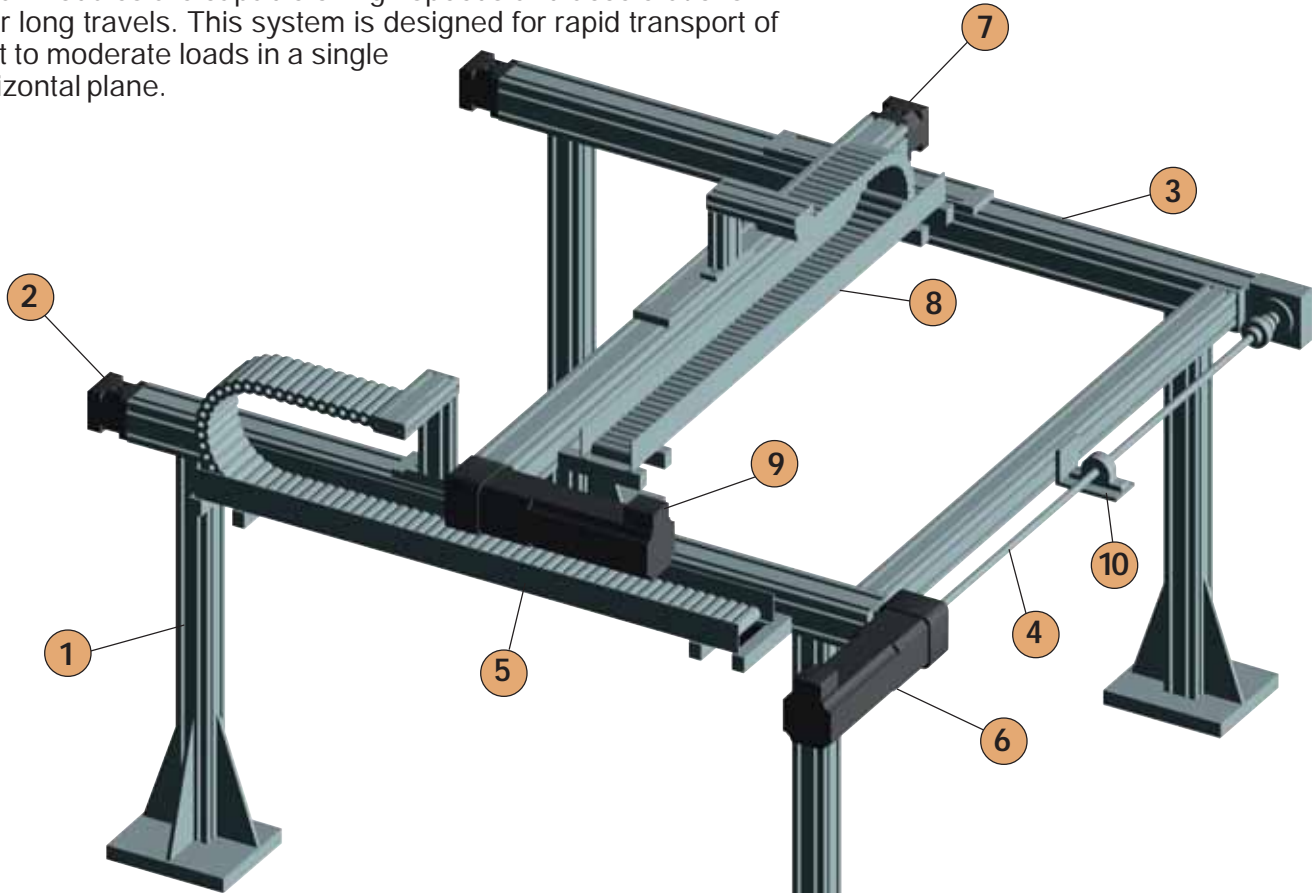
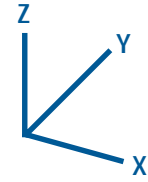

- 1 Support Structure Available (steel or aluminum framing)
- 2 X-Axis Drive Rail Assembly
- 3 X-Axis Driven Rail Assembly
- 4 X-Axis Link Shaft Assembly
- 5 X-Axis Cable Carrier
- 6 X-Axis Drive Motor
- 7 Y-Axis Drive Rail Assembly
- 8 Y-Axis Cable Carrier
- 9 Y-Axis Drive Motor
- 10 Pillow Block Bearing & Support (Based on Application)

Note: Loads, travels, and velocities shown are interdependent. Increased values are attainable.

Series No.	Axis Model Number			Load (kg)	Travel			Velocity		
	X-Axis	Y-Axis	Z-Axis		X-Axis (meters)	Y-Axis (meters)	Z-Axis (meters)	X-Axis (m/sec.)	Y-Axis (m/sec.)	Z-Axis (m/sec.)
1	HLE60RB	HLE60RB	—	15	2.9	1.3	—	2.0	2.0	—
2	HLE60SR	HLE60SR	—	25	2.8	1.3	—	2.0	2.0	—
3	HPLA080	HPLA080	—	30	5.4	2.0	—	2.0	3.0	—
4	HLE100RB	HLE100RB	—	35	6.0	2.0	—	2.0	3.0	—
5	HLE100SR	HLE100SR	—	75	6.0	2.0	—	2.0	3.0	—
6	HPLA120	HPLA120	—	85	9.3	3.0	—	2.0	3.0	—
7	HLE150RB	HLE150RB	—	100	7.9	3.0	—	2.0	3.0	—

System One Dimensions

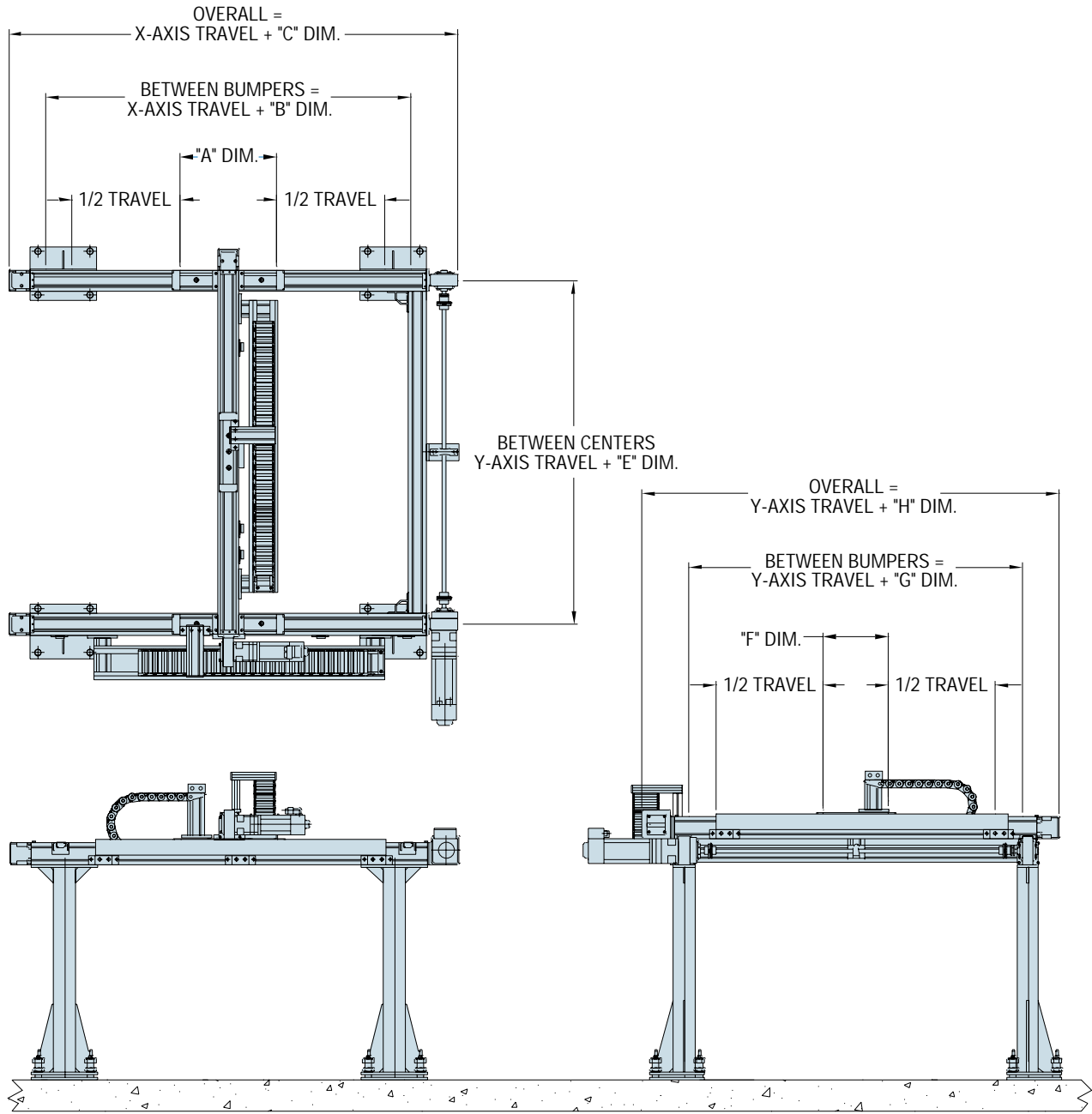

Belt Driven Modules

Series No.	System One (XX'-Y)						
	"A" Dim. mm (in)	"B" Dim. mm (in)	"C" Dim. mm (in)	"E" Dim. mm (in)	"F" Dim. mm (in)	"G" Dim. mm (in)	"H" Dim. mm (in)
1	254.0 (10.00)	504.0 (19.84)	730.0 (28.74)	406.2 (15.99)	152.4 (6.00)	402.4 (15.84)	628.4 (24.74)
2	254.0 (10.00)	504.0 (19.84)	720.0 (28.35)	380.2 (14.97)	152.4 (6.00)	402.4 (15.84)	618.0 (24.33)
3	400.0 (15.75)	650.0 (25.59)	1012.0 (39.84)	530.0 (20.87)	250.0 (9.84)	500.0 (19.69)	862.0 (33.94)
4	450.0 (17.72)	700.0 (27.56)	1090.0 (42.91)	588.0 (23.15)	300.0 (11.81)	550.0 (21.65)	940.0 (37.01)
5	450.0 (17.72)	700.0 (27.56)	1141.0 (44.92)	605.0 (23.82)	300.0 (11.81)	550.0 (21.65)	991.0 (39.02)
6	500.0 (19.69)	750.0 (29.53)	1205.0 (47.44)	560.0 (22.05)	300.0 (11.81)	550.0 (21.65)	1005.0 (39.57)
7	500.0 (19.69)	750.0 (29.53)	1220.0 (48.03)	612.0 (24.09)	350.0 (13.78)	600.0 (23.62)	1070.0 (42.13)



System Two

System Two utilizes two linear modules in both axes (X & Y). The second linear module of the Y-axis is an idler unit which increases load capacity (normal and moment) and permits longer travel. The addition of this unit doubles the load capacity over System One. Traction force can be improved by linking the second axis (Y) module to the first with a common drive shaft. The link shaft doubles the potential acceleration of the system. This system is intended for moderate to heavy loads.

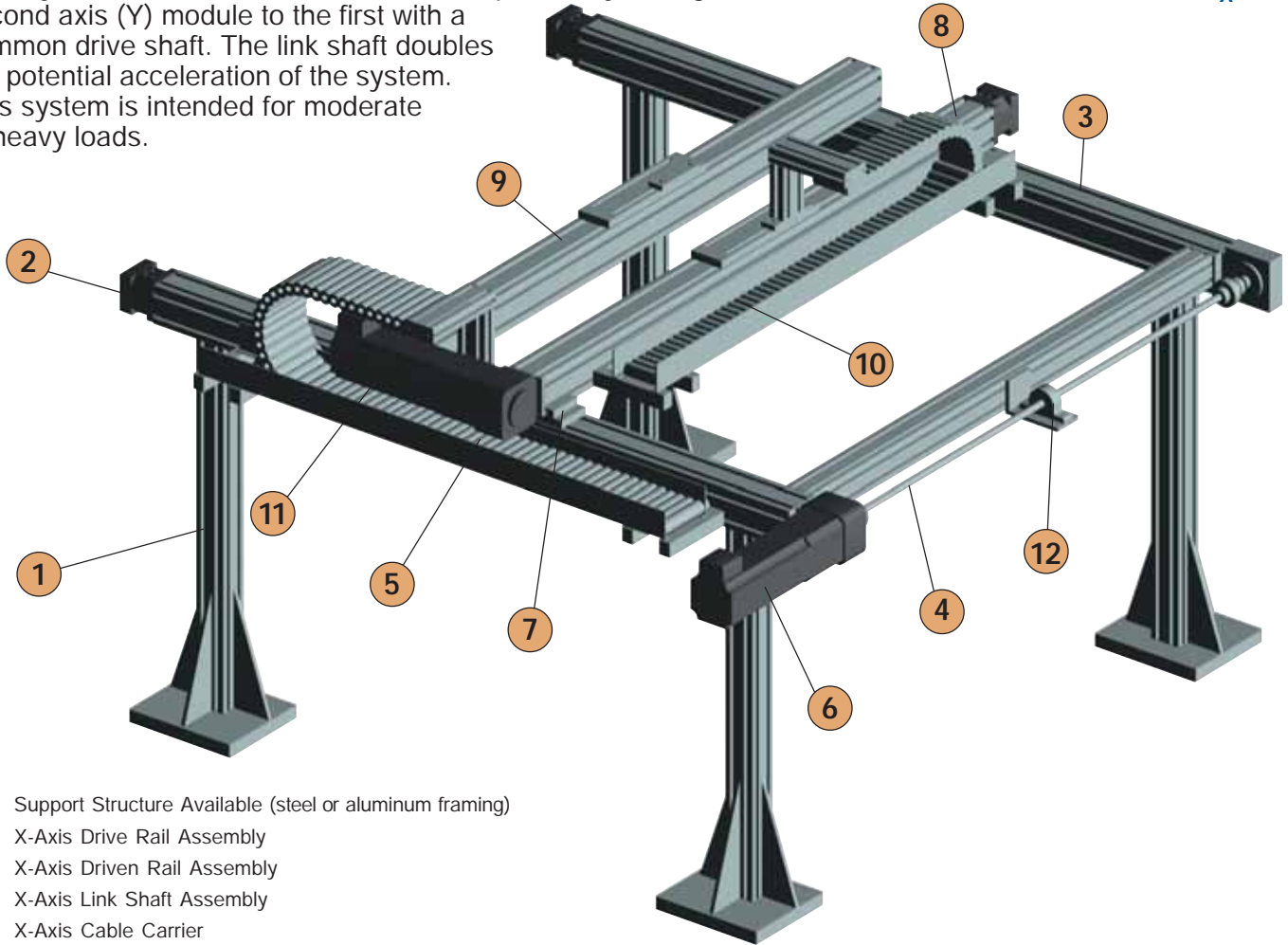
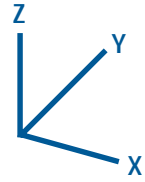

- 1 Support Structure Available (steel or aluminum framing)
- 2 X-Axis Drive Rail Assembly
- 3 X-Axis Driven Rail Assembly
- 4 X-Axis Link Shaft Assembly
- 5 X-Axis Cable Carrier
- 6 X-Axis Drive Motor
- 7 Clamping Profile
- 8 Y-Axis Drive Rail Assembly
- 9 Y-Axis Idler Rail Assembly
- 10 Y-Axis Cable Carrier
- 11 Y-Axis Drive Motor
- 12 Pillow Block Bearing & Support (Based on Application)

Note: Loads, travels, and velocities shown are interdependent. Increased values are attainable.

Series No.	Axis Model Number			Load (kg)	Travel (meters)			Velocity (m/sec.)		
	X-Axis	Y-Axis	Z-Axis		X-Axis	Y-Axis	Z-Axis	X-Axis	Y-Axis	Z-Axis
1	HLE60RB	HLE60RB	—	30	2.9	1.3	—	1.0	2.0	—
2	HLE60SR	HLE60SR	—	50	2.8	1.3	—	1.0	2.0	—
3	HPLA080	HPLA080	—	60	5.4	2.0	—	2.0	3.0	—
4	HLE100RB	HLE100RB	—	70	6.0	2.0	—	1.5	4.0	—
5	HLE100SR	HLE100SR	—	150	6.0	2.0	—	1.5	4.0	—
6	HPLA120	HPLA120	—	170	9.3	3.0	—	2.0	4.0	—
7	HLE150RB	HLE150RB	—	200	7.9	3.0	—	2.0	4.0	—

System Two Dimensions

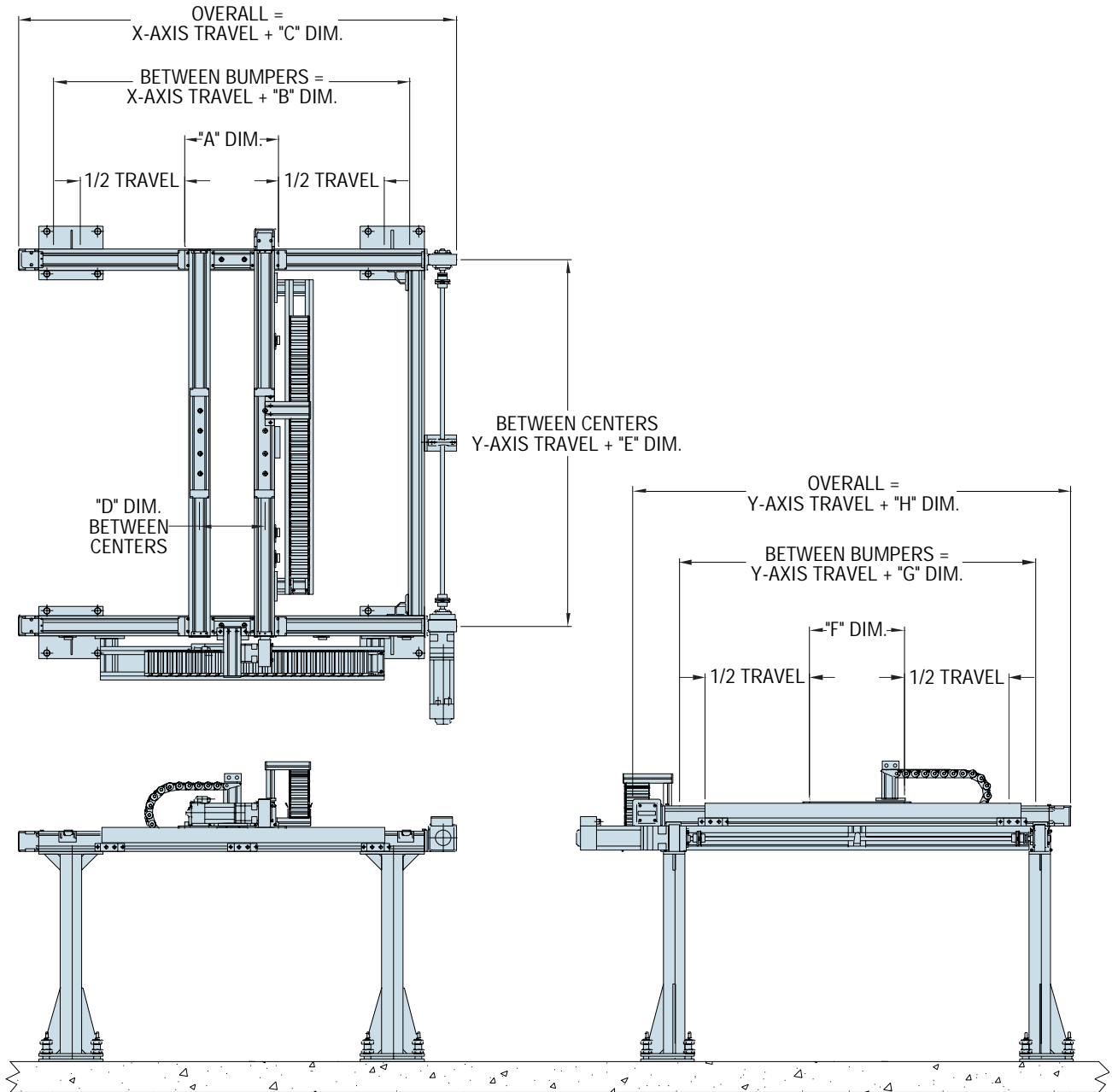

Belt Driven Modules

Series No.	System Two (XX'-YY')							
	"A" Dim. mm (in)	"B" Dim. mm (in)	"C" Dim. mm (in)	"D" Dim. mm (in)	"E" Dim. mm (in)	"F" Dim. mm (in)	"G" Dim. mm (in)	"H" Dim. mm (in)
1	254.0 (10.00)	504.0 (19.84)	730.0 (28.74)	169.8 (6.69)	508.2 (20.01)	254.0 (10.00)	504.0 (19.84)	730.0 (28.74)
2	254.0 (10.00)	504.0 (19.84)	720.0 (28.35)	169.8 (6.69)	482.2 (18.98)	254.0 (10.00)	504.0 (19.84)	720.0 (28.35)
3	400.0 (15.75)	650.0 (25.59)	1012.0 (39.84)	280.0 (11.02)	680.0 (26.77)	400.0 (15.75)	650.0 (25.59)	1012.0 (39.84)
4	450.0 (17.72)	700.0 (27.56)	1090.0 (42.91)	310.0 (12.21)	738.0 (29.06)	450.0 (17.72)	700.0 (27.56)	1090.0 (42.91)
5	450.0 (17.72)	700.0 (27.56)	1141.0 (44.92)	310.0 (12.21)	755.0 (29.72)	450.0 (17.72)	700.0 (27.56)	1141.0 (44.92)
6	500.0 (19.69)	750.0 (29.53)	1205.0 (47.44)	330.0 (12.99)	760.0 (29.92)	500.0 (19.69)	750.0 (29.53)	1205.0 (47.44)
7	500.0 (19.69)	750.0 (29.53)	1220.0 (48.03)	300.0 (11.81)	762.0 (30.00)	500.0 (19.69)	750.0 (29.53)	1220.0 (48.03)



System Three

System Three provides two axes of motion in a vertical plane. A ballscrew driven ET Cylinder is utilized to provide high thrust in the vertical direction. ET Rod Guides, in conjunction with the dual X-axis, minimize the effects of moment and side loading, permitting higher acceleration of the payload.

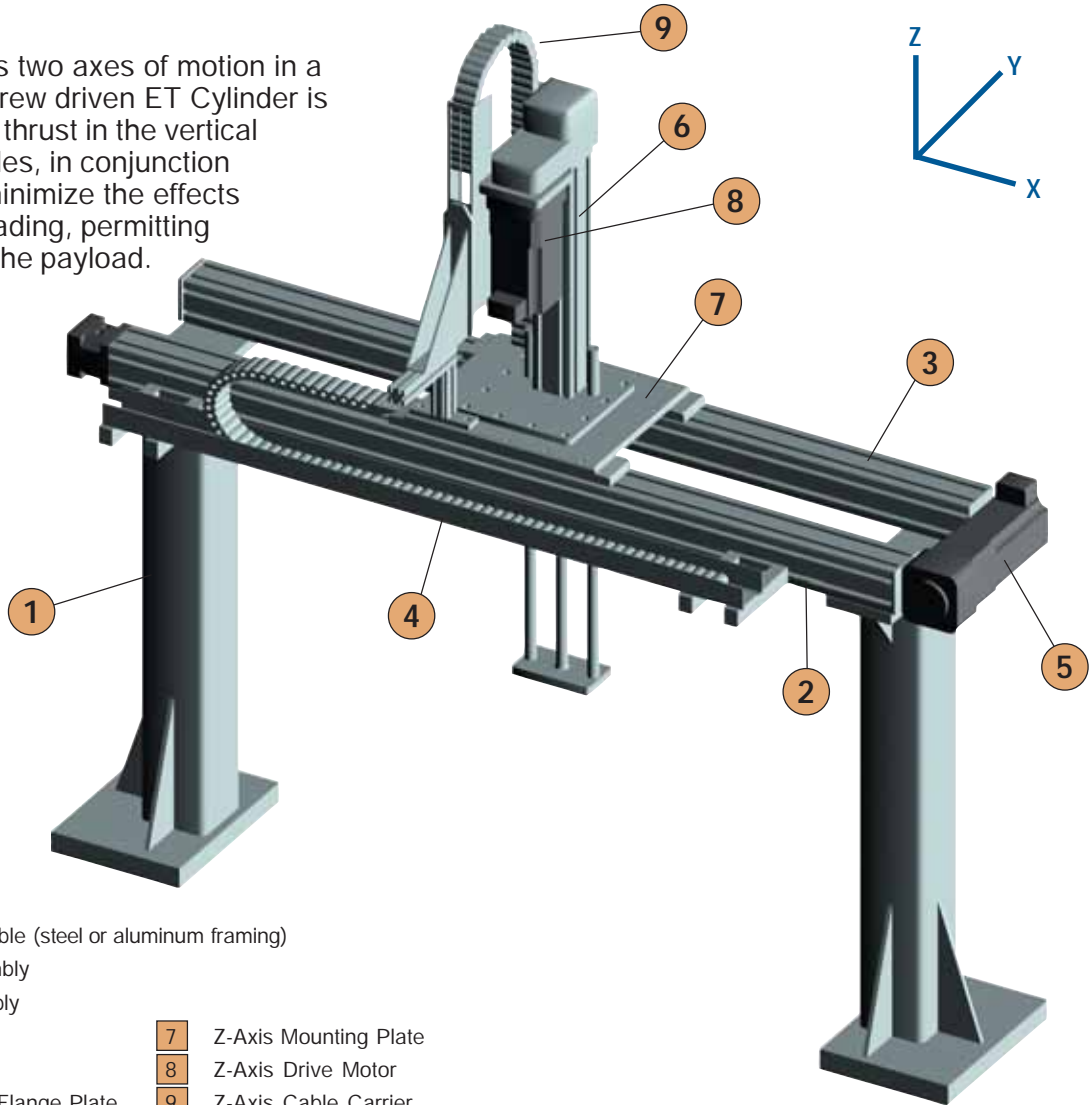

- 1 Support Structure Available (steel or aluminum framing)
- 2 X-Axis Drive Rail Assembly
- 3 X-Axis Idler Rail Assembly
- 4 X-Axis Cable Carrier
- 5 X-Axis Drive Motor
- 6 ET Cylinder Z-Axis with Flange Plate
- 7 Z-Axis Mounting Plate
- 8 Z-Axis Drive Motor
- 9 Z-Axis Cable Carrier

Note: Loads, travels, and velocities shown are interdependent. Increased values are attainable.

Series No.	Axis Model Number			Load (kg)	Travel			Velocity		
	X-Axis	Y-Axis	Z-Axis		X-Axis (meters)	Y-Axis (meters)	Z-Axis (meters)	X-Axis (m/sec.)	Y-Axis (m/sec.)	Z-Axis (m/sec.)
1	HLE60RB	—	ETB32	10	2.9	—	0.3	1.5	—	0.5
2	HLE60RB	—	ETB50	20	2.9	—	0.5	1.5	—	0.8
3	HLE60SR	—	ETB32	10	2.8	—	0.3	1.5	—	0.5
4	HLE60SR	—	ETB50	20	2.8	—	0.5	1.5	—	0.8
5	HPLA080	—	ETB50	35	5.4	—	0.5	2.0	—	0.8
6	HLE100RB	—	ETB50	40	6.0	—	0.5	2.0	—	0.8
7	HLE100RB	—	ETB80	50	6.0	—	1.0	2.0	—	0.5
8	HLE100SR	—	ETB50	40	6.0	—	0.5	2.0	—	0.5
9	HLE100SR	—	ETB80	50	6.0	—	1.0	2.0	—	0.5
10	HPLA120	—	ETB80	75	9.3	—	1.0	2.5	—	0.5
11	HPLA120	—	ETB100	100	9.3	—	1.0	2.5	—	1.0
12	HLE150RB	—	ETB80	75	7.9	—	1.0	2.5	—	0.5
13	HLE150RB	—	ETB100	100	7.9	—	1.0	2.5	—	1.0

System Three Dimensions

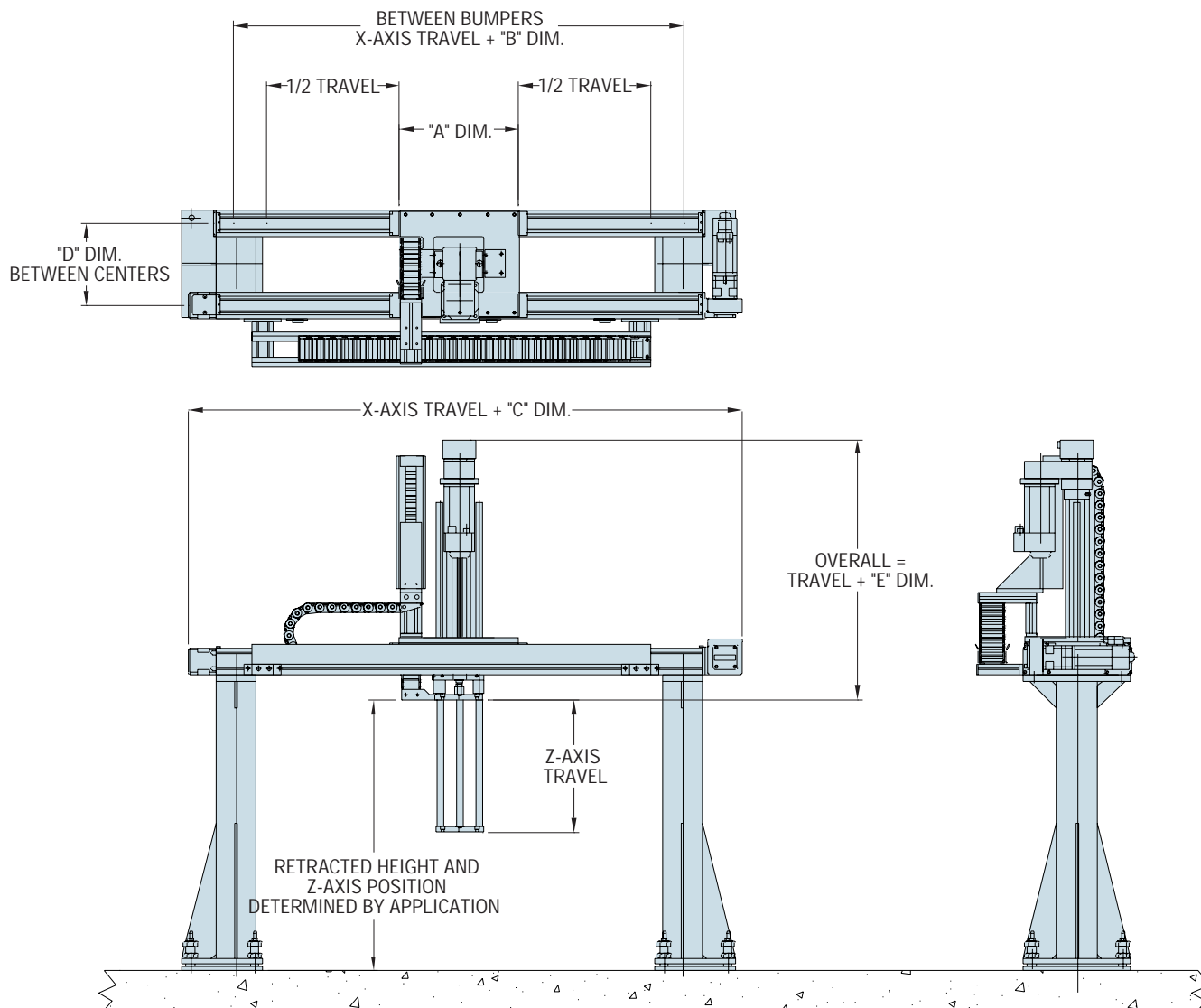

Series No.	System Three XX'-Z (Electric Cylinder)				
	"A" Dim. mm (in)	"B" Dim. mm (in)	"C" Dim. mm (in)	"D" Dim. mm (in)	"E" Dim. mm (in)
1	254.0 (10.00)	504.0 (19.84)	730.0 (28.74)	200.0 (7.87)	238.0 (9.37)
2	254.0 (10.00)	504.0 (19.84)	730.0 (28.74)	200.0 (7.87)	304.1 (11.97)
3	254.0 (10.00)	504.0 (19.84)	720.0 (28.35)	200.0 (7.87)	238.0 (9.37)
4	254.0 (10.00)	504.0 (19.84)	720.0 (28.35)	200.0 (7.87)	304.1 (11.97)
5	400.0 (15.75)	650.0 (25.59)	1012.0 (39.84)	250.0 (9.84)	304.1 (11.97)
6	450.0 (17.72)	700.0 (27.56)	1090.0 (42.91)	300.0 (11.81)	304.1 (11.97)
7	450.0 (17.72)	700.0 (27.56)	1090.0 (42.91)	300.0 (11.81)	321.9 (12.67)
8	450.0 (17.72)	700.0 (27.56)	1141.0 (44.92)	300.0 (11.81)	304.1 (11.97)
9	450.0 (17.72)	700.0 (27.56)	1141.0 (44.92)	300.0 (11.81)	321.9 (12.67)
10	500.0 (19.69)	750.0 (29.53)	1205.0 (47.44)	350.0 (13.78)	321.9 (12.67)
11	500.0 (19.69)	750.0 (29.53)	1205.0 (47.44)	350.0 (13.78)	494.0 (19.45)
12	500.0 (19.69)	750.0 (29.53)	1220.0 (48.03)	350.0 (13.78)	321.9 (12.67)
13	500.0 (19.69)	750.0 (29.53)	1220.0 (48.03)	350.0 (13.78)	494.0 (19.45)



System Four

System Four is a variation of System Three that offers an alternative mounting arrangement. It is a popular choice for front loading applications and is often implemented as a wall mount unit.

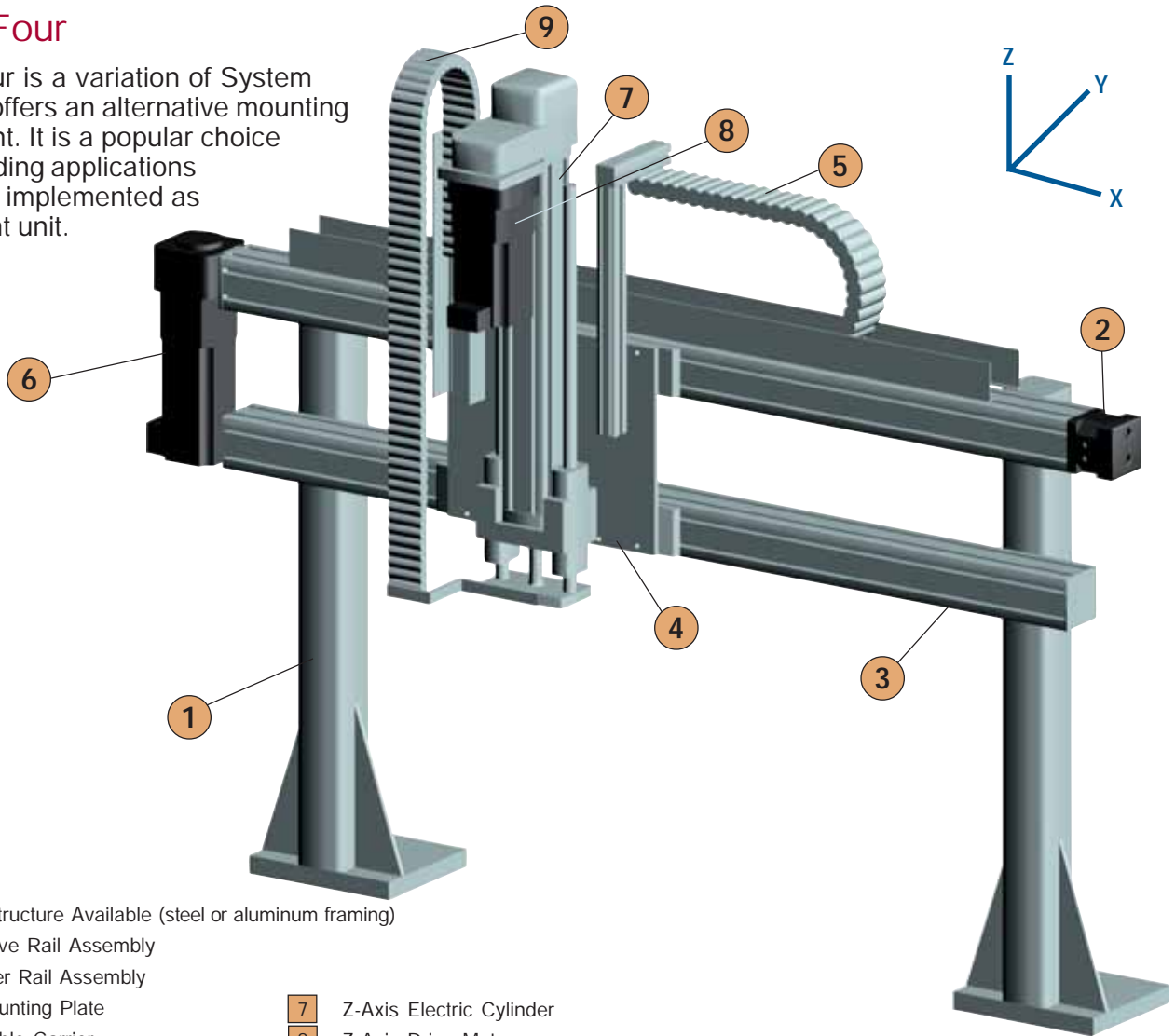

- 1 Support Structure Available (steel or aluminum framing)
- 2 X-Axis Drive Rail Assembly
- 3 X-Axis Idler Rail Assembly
- 4 Z-Axis Mounting Plate
- 5 X-Axis Cable Carrier
- 6 X-Axis Drive Motor
- 7 Z-Axis Electric Cylinder
- 8 Z-Axis Drive Motor
- 9 Z-Axis Cable Carrier

Note: Loads, travels, and velocities shown are interdependent. Increased values are attainable.

Series No.	Axis Model Number			Load (kg)	Travel			Velocity		
	X-Axis	Y-Axis	Z-Axis		X-Axis (meters)	Y-Axis (meters)	Z-Axis (meters)	X-Axis (m/sec.)	Y-Axis (m/sec.)	Z-Axis (m/sec.)
1	HLE60RB	—	ETB32	10	2.9	—	0.3	1.5	—	0.5
2	HLE60RB	—	ETB50	20	2.9	—	0.5	1.5	—	0.8
3	HLE60SR	—	ETB32	10	2.8	—	0.3	1.5	—	0.5
4	HLE60SR	—	ETB50	20	2.8	—	0.5	1.5	—	0.8
5	HPLA080	—	ETB50	35	5.4	—	0.5	2.0	—	0.8
6	HLE100RB	—	ETB50	40	6.0	—	0.5	2.0	—	0.8
7	HLE100RB	—	ETB80	50	6.0	—	1.0	2.0	—	0.5
8	HLE100SR	—	ETB50	40	6.0	—	0.5	2.0	—	0.5
9	HLE100SR	—	ETB80	50	6.0	—	1.0	2.0	—	0.5
10	HPLA120	—	ETB80	75	9.3	—	1.0	2.5	—	0.5
11	HPLA120	—	ETB100	100	9.3	—	1.0	2.5	—	1.0
12	HLE150RB	—	ETB80	75	7.9	—	1.0	2.5	—	0.5
13	HLE150RB	—	ETB100	100	7.9	—	1.0	2.5	—	1.0

System Four Dimensions

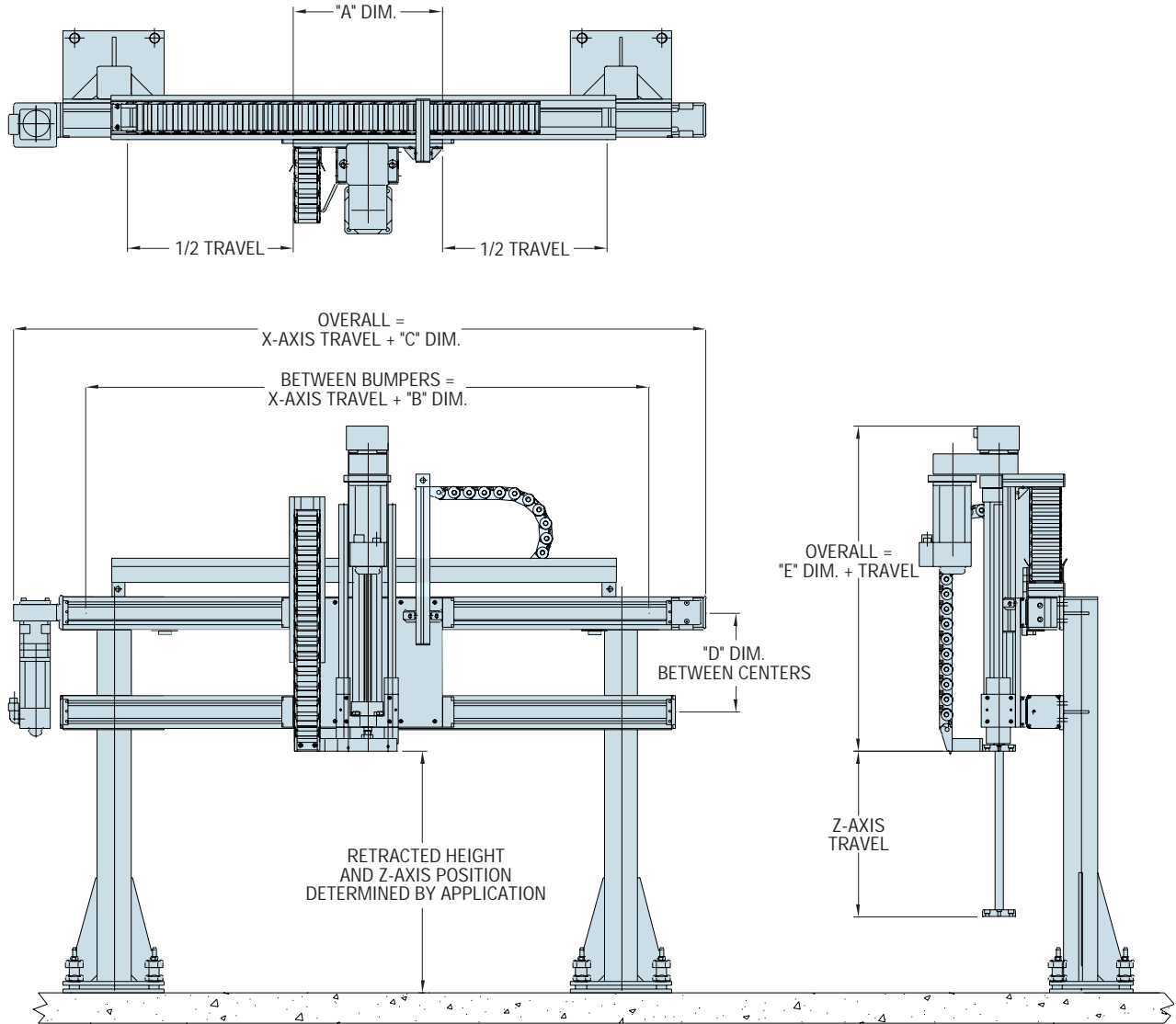

Series No.	System Four XX'-Z (Electric Cylinder)				
	"A" Dim. mm (in)	"B" Dim. mm (in)	"C" Dim. mm (in)	"D" Dim. mm (in)	"E" Dim. mm (in)
1	254.0 (10.00)	504.0 (19.84)	730.0 (28.74)	200.0 (7.87)	238.0 (9.37)
2	254.0 (10.00)	504.0 (19.84)	730.0 (28.74)	200.0 (7.87)	304.1 (11.97)
3	254.0 (10.00)	504.0 (19.84)	720.0 (28.35)	200.0 (7.87)	238.0 (9.37)
4	254.0 (10.00)	504.0 (19.84)	720.0 (28.35)	200.0 (7.87)	304.1 (11.97)
5	400.0 (15.75)	650.0 (25.59)	1012.0 (39.84)	250.0 (9.84)	304.1 (11.97)
6	450.0 (17.72)	700.0 (27.56)	1090.0 (42.91)	300.0 (11.81)	304.1 (11.97)
7	450.0 (17.72)	700.0 (27.56)	1090.0 (42.91)	300.0 (11.81)	321.9 (12.67)
8	450.0 (17.72)	700.0 (27.56)	1141.0 (44.92)	300.0 (11.81)	304.1 (11.97)
9	450.0 (17.72)	700.0 (27.56)	1141.0 (44.92)	300.0 (11.81)	321.9 (12.67)
10	500.0 (19.69)	750.0 (29.53)	1205.0 (47.44)	350.0 (13.78)	321.9 (12.67)
11	500.0 (19.69)	750.0 (29.53)	1205.0 (47.44)	350.0 (13.78)	494.0 (19.45)
12	500.0 (19.69)	750.0 (29.53)	1220.0 (48.03)	350.0 (13.78)	321.9 (12.67)
13	500.0 (19.69)	750.0 (29.53)	1220.0 (48.03)	350.0 (13.78)	494.0 (19.45)



System Five

System Five is an X-Z system utilizing the HZR belt driven unit for the vertical axis. The rigidity of the HZR permits higher vertical speed, greater X-axis acceleration, and larger moment loading than System Three.

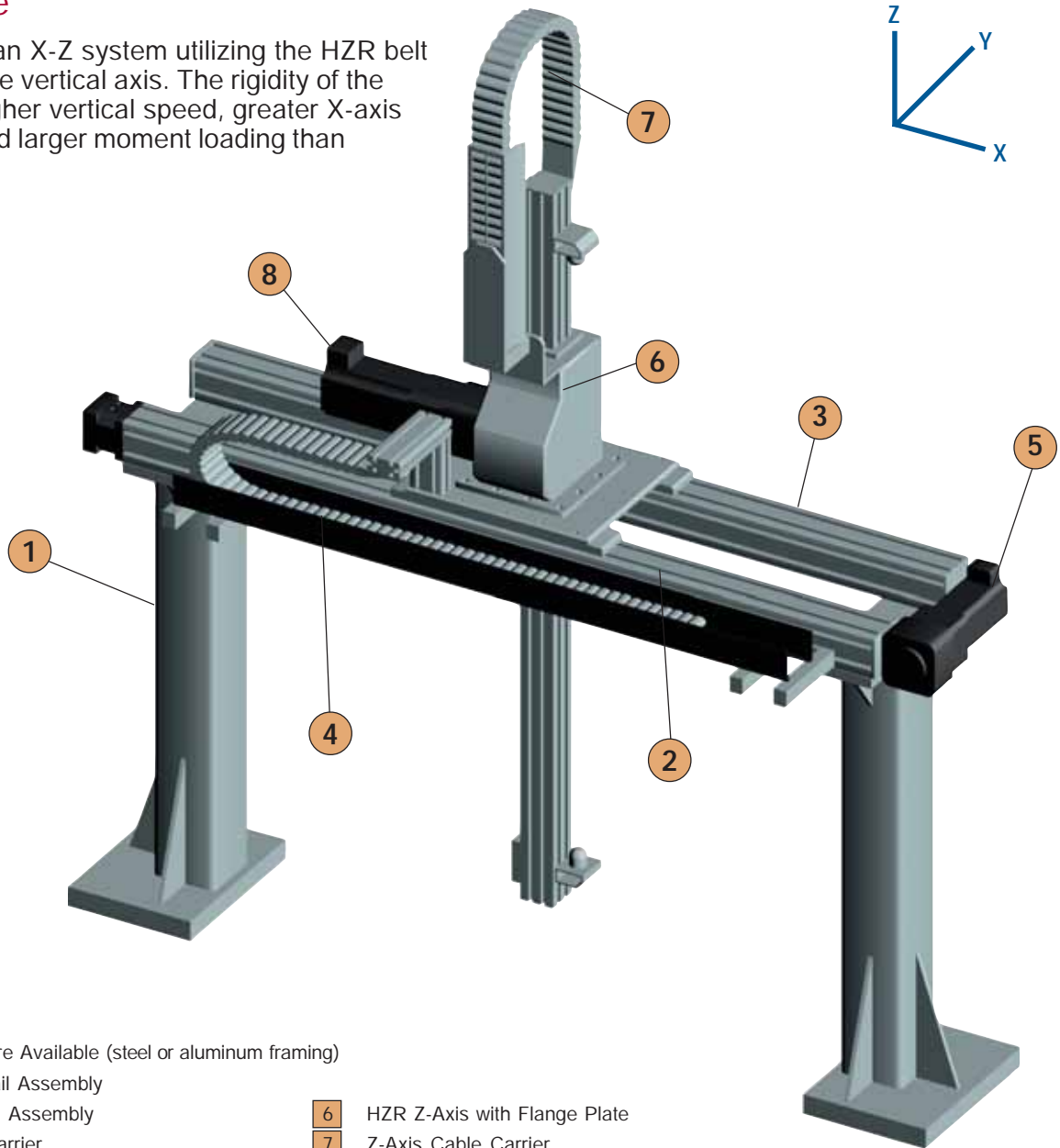

- 1** Support Structure Available (steel or aluminum framing)
- 2** X-Axis Drive Rail Assembly
- 3** X-Axis Idler Rail Assembly
- 4** X-Axis Cable Carrier
- 5** X-Axis Drive Motor
- 6** HZR Z-Axis with Flange Plate
- 7** Z-Axis Cable Carrier
- 8** Z-Axis Drive Motor

Note: Loads, travels, and velocities shown are interdependent. Increased values are attainable.

Series No.	Axis Model Number			Load (kg)	Travel			Velocity		
	X-Axis	Y-Axis	Z-Axis		X-Axis (meters)	Y-Axis (meters)	Z-Axis (meters)	X-Axis (m/sec.)	Y-Axis (m/sec.)	Z-Axis (m/sec.)
1	HLE100RB	—	HZR80	50	6.0	—	1.0	2.0	—	1.5
2	HLE100RB	—	HZR100	100	6.0	—	1.5	2.0	—	1.5
3	HLE100SR	—	HZR80	50	6.0	—	1.0	2.0	—	1.5
4	HLE100SR	—	HZR100	100	6.0	—	1.5	2.0	—	1.5
5	HPLA120	—	HZR80	50	9.3	—	1.0	2.5	—	1.5
6	HPLA120	—	HZR100	100	9.3	—	1.5	2.5	—	1.5
7	HLE150RB	—	HZR80	50	7.9	—	1.0	2.5	—	1.5
8	HLE150RB	—	HZR100	100	7.9	—	1.5	2.5	—	1.5

System Five Dimensions

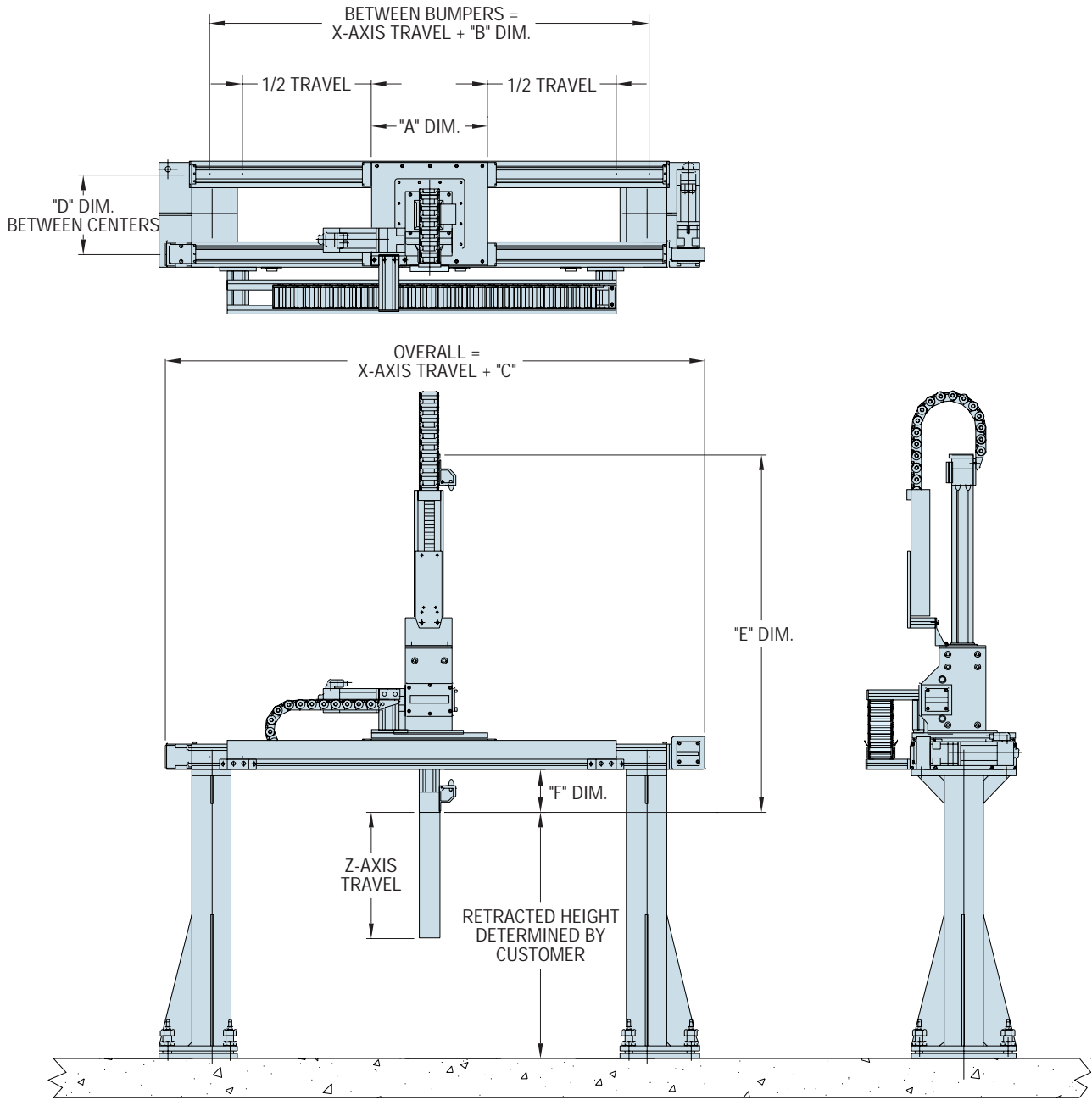

Series No.	System Five XX'-Z (HZR)					
	"A" Dim. mm (in)	"B" Dim. mm (in)	"C" Dim. mm (in)	"D" Dim. mm (in)	"E" Dim. mm (in)	"F" Dim. mm (in)
1	450.0 (17.72)	700.0 (27.56)	1090.0 (42.91)	310.0 (12.21)	885.0 (34.84)	170.0 (6.69)
2	450.0 (17.72)	700.0 (27.56)	1090.0 (42.91)	360.0 (14.17)	1030.0 (40.55)	245.0 (9.65)
3	450.0 (17.72)	700.0 (27.56)	1141.0 (44.92)	310.0 (12.21)	885.0 (34.84)	170.0 (6.69)
4	450.0 (17.72)	700.0 (27.56)	1141.0 (44.92)	360.0 (14.17)	1030.0 (40.55)	245.0 (9.65)
5	500.0 (19.69)	750.0 (29.53)	1205.0 (47.44)	400.0 (15.75)	885.0 (34.84)	115.0 (4.53)
6	500.0 (19.69)	750.0 (29.53)	1205.0 (47.44)	400.0 (15.75)	1030.0 (40.55)	190.0 (7.48)
7	500.0 (19.69)	750.0 (29.53)	1220.0 (48.03)	400.0 (15.75)	885.0 (34.84)	115.0 (4.53)
8	500.0 (19.69)	750.0 (29.53)	1220.0 (48.03)	400.0 (15.75)	1030.0 (40.55)	190.0 (7.48)



System Six

System Six is a three axis version of System Two. HPLA/HLE linear modules provide motion in the X and Y directions while a vertically mounted ET cylinder provides the third axis (Z) of motion. The ET cylinder provides high vertical thrust capacity at moderate speeds. With the Z-axis retracted, this system can transport moderate to heavy loads at high rates of speed over long travel distances.

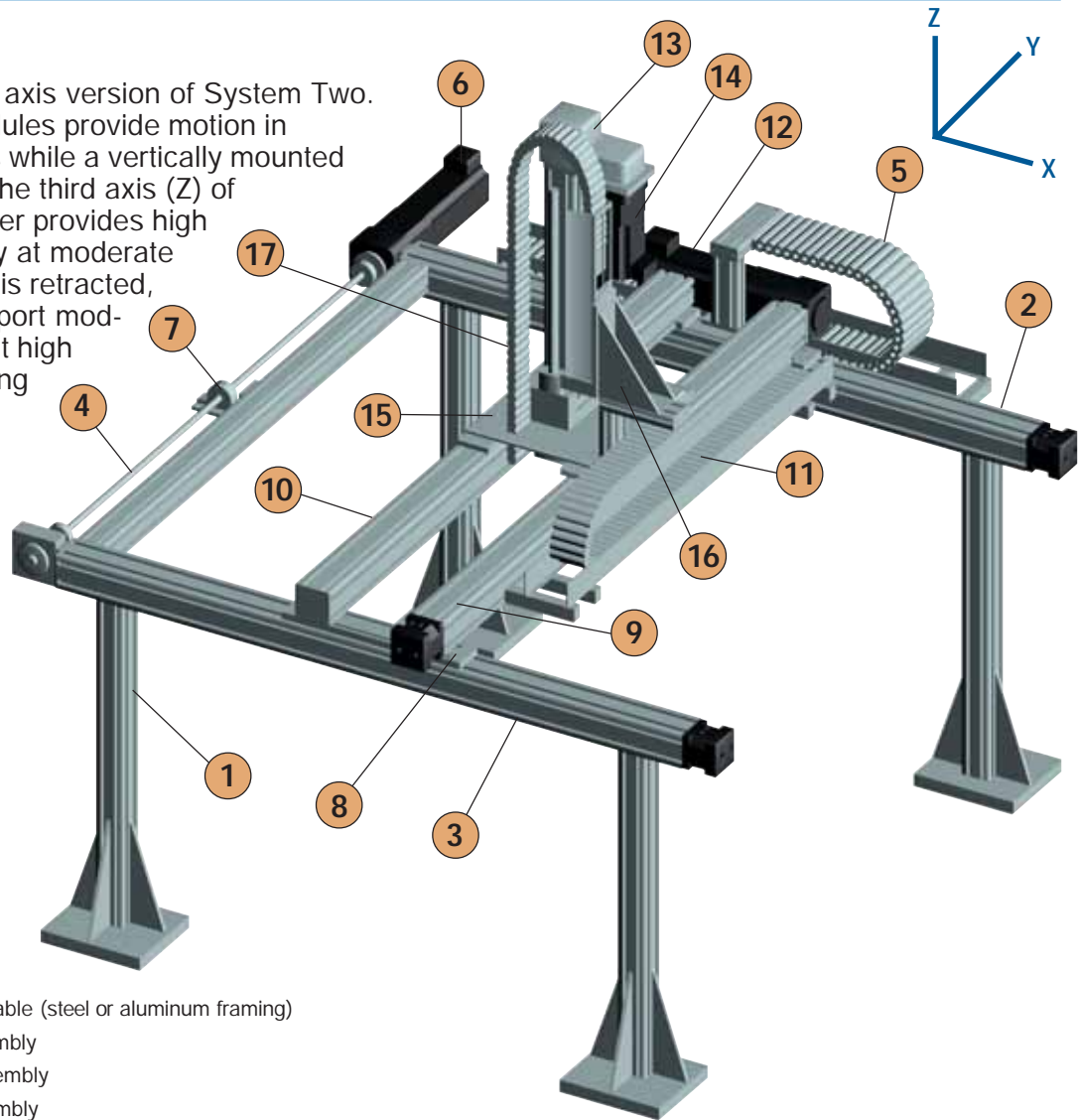

- | | | | | | |
|---|---|----|-----------------------------|----|------------------------------------|
| 1 | Support Structure Available (steel or aluminum framing) | 10 | Y-Axis Idler Rail Assembly | 14 | Z-Axis Drive Motor |
| 2 | X-Axis Drive Rail Assembly | 11 | Y-Axis Cable Carrier | 15 | Electric Cylinder Mounting Plate |
| 3 | X-Axis Driven Rail Assembly | 12 | Y-Axis Drive Motor | 16 | Electric Cylinder Mounting Bracket |
| 4 | X-Axis Link Shaft Assembly | 13 | Z-Axis ET Electric Cylinder | 17 | Z-Axis Cable Carrier |
| 5 | X-Axis Cable Carrier | | | | |
| 6 | X-Axis Drive Motor | | | | |
| 7 | Pillow Block Bearing Support (Based on Application) | | | | |
| 8 | Clamping Profile | | | | |
| 9 | Y-Axis Drive Rail Assembly | | | | |

Note: Loads, travels, and velocities shown are interdependent. Increased values are attainable.

Series No.	Axis Model Number			Load (kg)	Travel (meters)			Velocity (m/sec.)		
	X-Axis	Y-Axis	Z-Axis		X-Axis	Y-Axis	Z-Axis	X-Axis	Y-Axis	Z-Axis
1	HLE60RB	HLE60RB	ETB32	10	2.9	1.0	0.3	1.0	1.5	0.5
2	HLE60RB	HLE60RB	ETB50	20	2.9	0.5	0.5	1.0	1.5	0.8
3	HLE60SR	HLE60SR	ETB32	10	2.8	1.0	0.3	1.0	1.5	0.5
4	HLE60SR	HLE60SR	ETB50	20	2.8	0.5	0.5	1.0	1.5	0.8
5	HPLA080	HPLA080	ETB50	45	5.4	1.5	0.5	2.0	2.0	0.8
6	HLE100RB	HLE100RB	ETB80	50	6.0	1.5	1.0	2.0	2.0	0.5
7	HLE100SR	HLE100SR	ETB80	50	6.0	1.4	1.0	2.0	2.0	0.5
8	HPLA120	HPLA120	ETB100	100	9.3	3.0	1.0	2.5	2.5	1.0
9	HLE150RB	HLE150RB	ETB100	100	7.9	3.0	1.0	2.5	2.5	1.0

System Six Dimensions

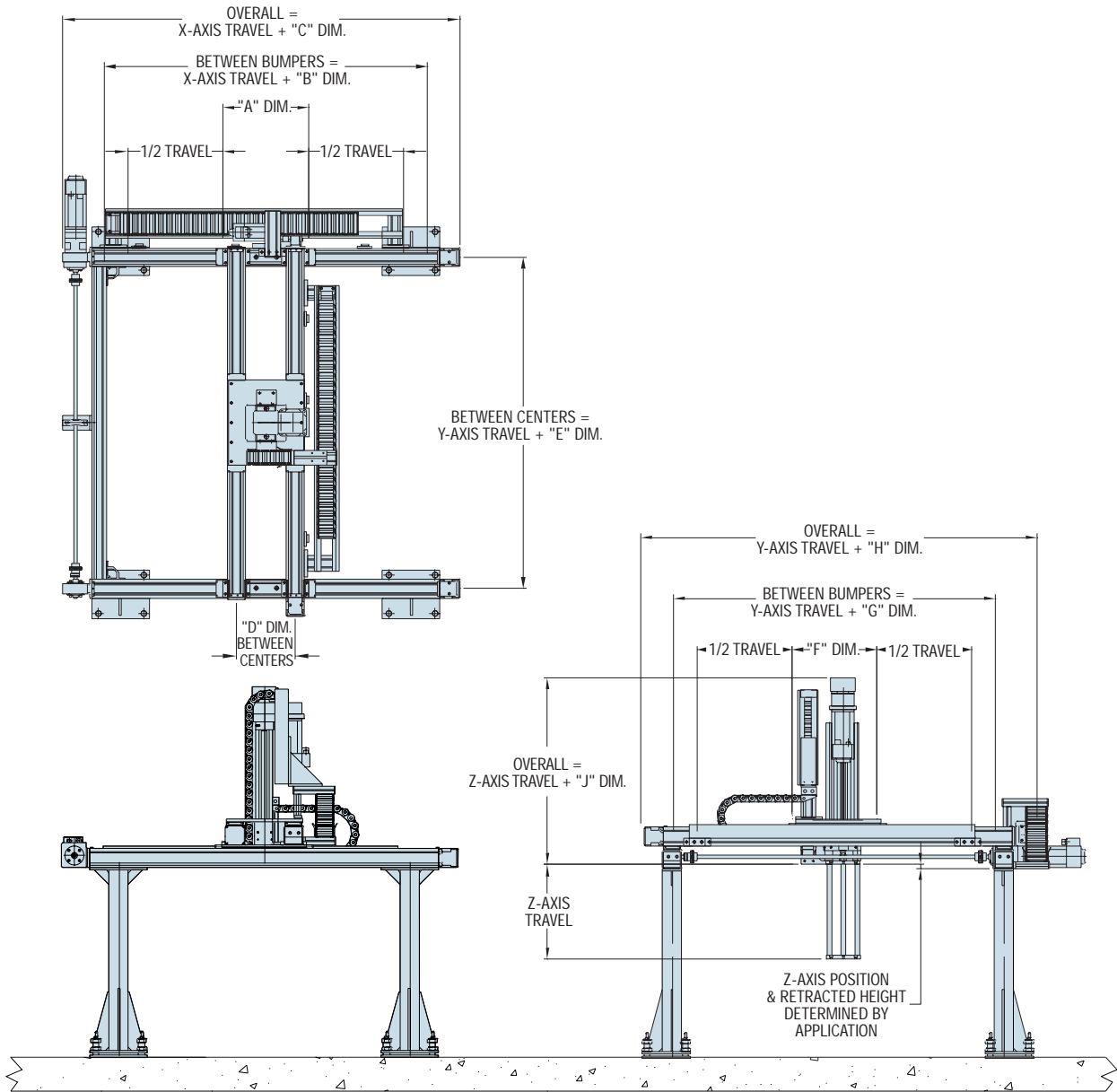

Series No.	System Six XX'-YY'-Z (Electric Cylinder)								
	"A" Dim. mm (in)	"B" Dim. mm (in)	"C" Dim. mm (in)	"D" Dim. mm (in)	"E" Dim. mm (in)	"F" Dim. mm (in)	"G" Dim. mm (in)	"H" Dim. mm (in)	"J" Dim. mm (in)
1	254.0 (10.00)	504.0 (19.84)	730.0 (28.74)	169.8 (6.69)	508.2 (20.01)	254.0 (10.00)	504.0 (19.84)	730.0 (28.74)	238.0 (9.37)
2	254.0 (10.00)	504.0 (19.84)	730.0 (28.74)	169.8 (6.69)	508.2 (20.01)	254.0 (10.00)	504.0 (19.84)	730.0 (28.74)	304.1 (11.97)
3	254.0 (10.00)	504.0 (19.84)	720.0 (28.35)	169.8 (6.69)	482.2 (19.98)	254.0 (10.00)	504.0 (19.84)	720.0 (28.35)	238.0 (9.37)
4	254.0 (10.00)	504.0 (19.84)	720.0 (28.35)	169.8 (6.69)	482.2 (19.98)	254.0 (10.00)	504.0 (19.84)	720.0 (28.35)	304.1 (11.97)
5	400.0 (15.75)	650.0 (25.59)	1012.0 (39.84)	280.0 (0.02)	680.0 (26.77)	400.0 (15.75)	650.0 (25.59)	1012.0 (39.84)	304.1 (11.97)
6	450.0 (17.72)	700.0 (27.56)	1090.0 (42.91)	310.0 (12.21)	738.0 (29.06)	450.0 (17.72)	700.0 (27.56)	1090.0 (42.91)	321.9 (12.67)
7	450.0 (17.72)	700.0 (27.56)	1141.0 (44.92)	310.0 (12.21)	755.0 (29.72)	450.0 (17.72)	700.0 (27.56)	1141.0 (44.92)	321.9 (12.67)
8	500.0 (19.69)	750.0 (29.53)	1205.0 (47.44)	330.0 (12.99)	760.0 (29.92)	500.0 (19.69)	750.0 (29.53)	1205.0 (47.44)	494.0 (19.45)
9	500.0 (19.69)	750.0 (29.53)	1220.0 (48.03)	300.0 (11.81)	762.0 (30.00)	500.0 (19.69)	750.0 (29.53)	1220.0 (48.03)	494.0 (19.45)



System Seven

System Seven is a three axis system which utilizes the HZR unit for the vertical axis. As a result, this system can provide longer vertical travel, higher speed, and greater acceleration than System Six. The inherent rigidity of the HZR also contributes to superior system stiffness, stability, and ease of tuning. If the Z-axis is retracted during horizontal motion, System Seven can easily handle moderate to heavy loads. With the Z-axis fully extended it can handle light to moderate loads.

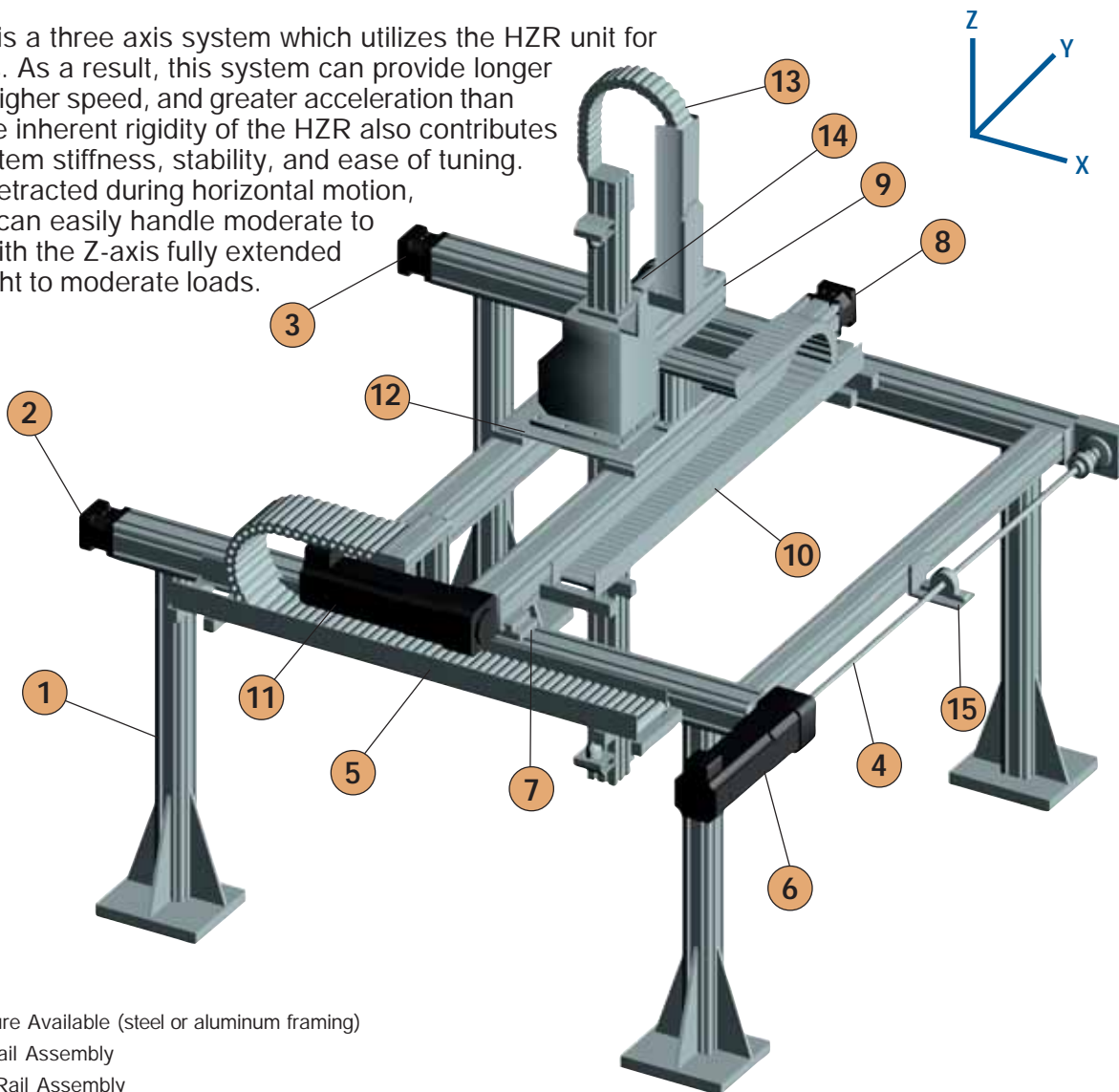

- | | | | | | |
|---|---|----|----------------------------|----|---|
| 1 | Support Structure Available (steel or aluminum framing) | 8 | Y-Axis Drive Rail Assembly | 12 | HZR Z-Axis with Flange Plate |
| 2 | X-Axis Drive Rail Assembly | 9 | Y-Axis Idler Rail Assembly | 13 | Z-Axis Cable Carrier |
| 3 | X-Axis Driven Rail Assembly | 10 | Y-Axis Cable Carrier | 14 | Z-Axis Drive Motor |
| 4 | X-Axis Link Shaft Assembly | 11 | Y-Axis Drive Motor | 15 | Pillow Block Bearing & Support (Based on Application) |
| 5 | X-Axis Cable Carrier | | | | |
| 6 | X-Axis Drive Motor | | | | |
| 7 | Clamping Profile | | | | |

Note: Loads, travels, and velocities shown are interdependent. Increased values are attainable.

Series No.	Axis Module Number			Load (kg)	Travel (meters)			Velocity (m/sec.)		
	X-Axis	Y-Axis	Z-Axis		X-Axis	Y-Axis	Z-Axis	X-Axis	Y-Axis	Z-Axis
1	HLE100RB	HLE100RB	HZR80	50	6.0	2.0	1.0	2.0	2.0	1.5
2	HLE100RB	HLE100RB	HZR100	100	6.0	1.3	1.5	2.0	2.0	1.5
3	HLE100SR	HLE100SR	HZR80	50	6.0	2.0	1.0	2.0	2.0	1.5
4	HLE100SR	HLE100SR	HZR100	100	6.0	1.3	1.5	2.0	2.0	1.5
5	HPLA120	HPLA120	HZR80	50	9.3	4.0	1.0	2.5	2.5	1.5
6	HPLA120	HPLA120	HZR100	100	9.3	3.3	1.5	2.5	2.5	1.5
7	HLE150RB	HLE150RB	HZR80	50	7.9	4.0	1.0	2.5	2.5	1.5
8	HLE150RB	HLE150RB	HZR100	100	7.9	3.3	1.5	2.5	2.5	1.5

System Seven Dimensions

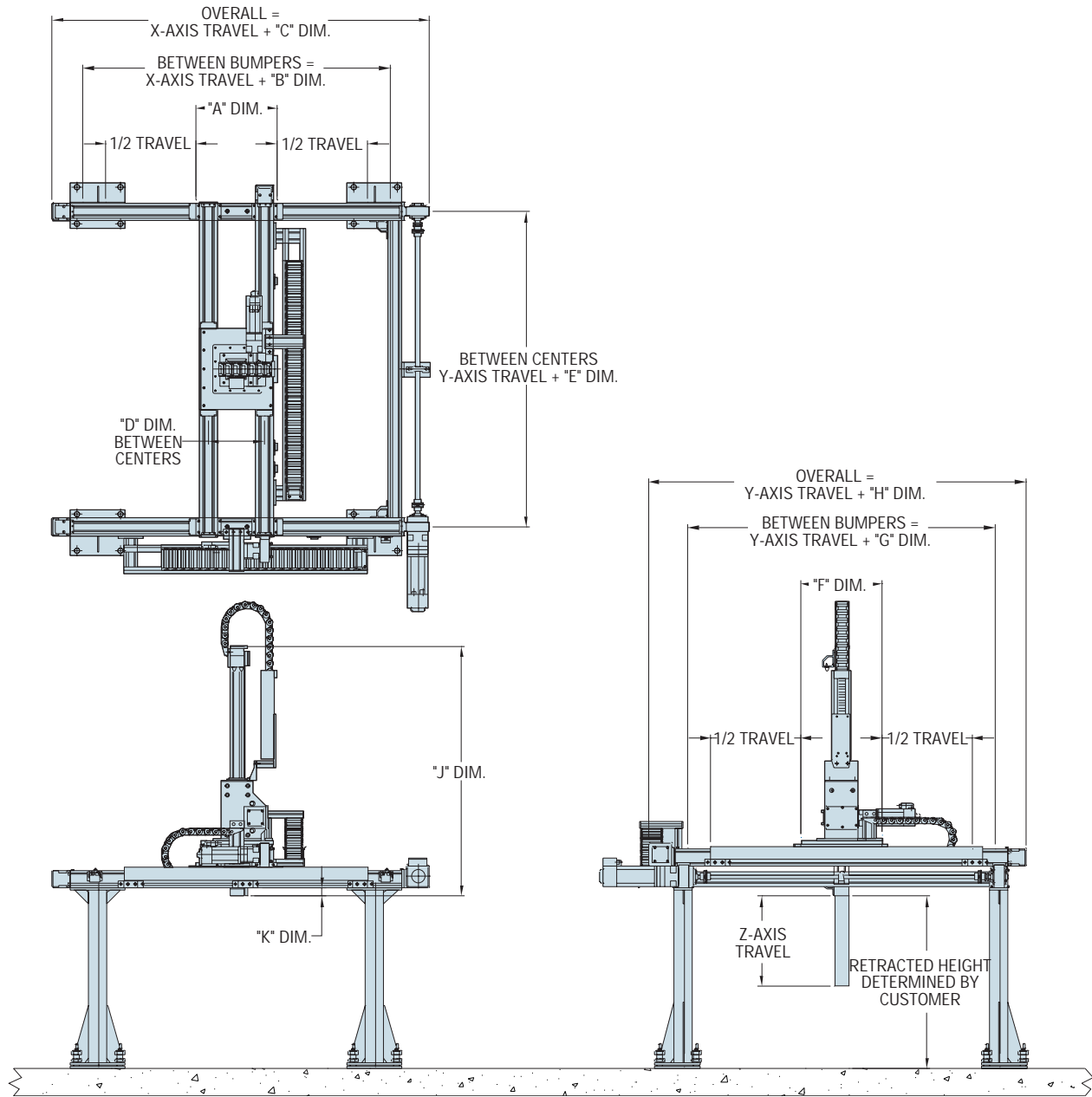

* Indicates bottom of Z-Axis is above bottom of X-Axis

Series No.	System Seven (XX'-YY'-HZR)									
	"A" Dim. mm (in)	"B" Dim. mm (in)	"C" Dim. mm (in)	"D" Dim. mm (in)	"E" Dim. mm (in)	"F" Dim. mm (in)	"G" Dim. mm (in)	"H" Dim. mm (in)	"J" Dim. mm (in)	"K" Dim. mm (in)
1	450 (17.72)	700 (27.56)	1090 (42.91)	310 (12.21)	738 (29.06)	450 (17.72)	700 (27.56)	1090 (42.91)	885 (34.84)	50 (1.97)
2	450 (17.72)	700 (27.56)	1090 (42.91)	310 (12.21)	738 (29.06)	450 (17.72)	700 (27.56)	1090 (42.91)	1030 (40.55)	125 (4.92)
3	450 (17.72)	700 (27.56)	1141 (44.92)	310 (12.21)	755 (29.72)	450 (17.72)	700 (27.56)	1141 (44.92)	885 (34.84)	50 (1.97)
4	450 (17.72)	700 (27.56)	1141 (44.92)	310 (12.21)	755 (29.72)	450 (17.72)	700 (27.56)	1141 (44.92)	1030 (40.55)	125 (4.92)
5	500 (19.69)	750 (29.53)	1205 (47.44)	330 (12.99)	760 (29.92)	500 (19.69)	750 (29.53)	1205 (47.44)	885 (34.84)	60 (2.36)
6	500 (19.69)	750 (29.53)	1205 (47.44)	330 (12.99)	760 (29.92)	500 (19.69)	750 (29.53)	1205 (47.44)	1030 (40.55)	15 (0.59)
7	550 (21.65)	800 (31.50)	1270 (50.00)	350 (13.78)	762 (30.00)	500 (19.69)	750 (29.53)	1220 (48.03)	885 (34.84)	60 (2.36)
8	600 (23.62)	850 (33.47)	1320 (51.97)	400 (15.75)	762 (30.00)	500 (19.69)	750 (29.53)	1220 (48.03)	1030 (40.55)	15 (0.59)



Linear Modules Introduction

Parker's family of linear modules provides the most comprehensive line of high throughput linear positioning devices in the industry. These electromechanical positioners are designed to shuttle a payload at high speeds to multiple locations along a linear travel path. They serve as the primary building blocks for Parker pre-engineered gantry systems or customer designed automation systems. Parker linear modules are offered in several unique product families which can address a broad range of travel, speed, load, accuracy, and environmental requirements. There are three bearing systems (polyamide roller, steel roller, or square rail), three drive types (belt-and-pulley or rack-and-pinion, or linear servo motor), and up to six different cross sectional sizes (60, 80, 100, 120, 150 and 180 mm) from which to choose. Systems designed around these elements have effectively, efficiently, and economically satisfied the widest range of application requirements for high speed automation.

HPLA Series / see pages D21 - D34

The next generation of belt driven modules, the HPLA expands on the roller wheel bearing design with the addition of high-load capacity steel wheels. The steel wheels significantly increase normal and moment load capacities of this belt driven actuator.

Features: Travel Range: 9.0 meters
Load Capacity: 1530 kg
Maximum Speed: 5 meters/sec.
Duty Cycle: 100%
Repeatability: ± 0.2 mm



BLMA Series / see pages D35 - D40

The BLMA is a plug and play motor actuator which houses a powerful linear servo motor (386 pounds of peak thrust) in a high strength rigid aluminum body to enable high end performance with highly repeatable positioning over long unsupported spans.

Features: Travel Range: 6.0 meters
Load Capacity: 700 kg
Maximum Speed: 7 meters/sec.
Duty Cycle: 100%
Repeatability: ± 0.01 mm

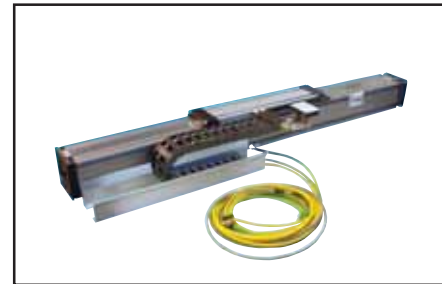

HLE-RB Series / see pages D41 - D56

These are the most popular electromechanical modules in the Parker line. They utilize a unique composite roller wheel bearing design coupled with a timing belt and pulley drive mechanism to provide long travel with high speed and high acceleration.

Features: Travel Range: 7.9 meters
Load Capacity: 600 kg
Maximum Speed: 5 meters/sec.
Duty Cycle: 100%
Repeatability: ± 0.2 mm



HLE-SR Series / see pages D57 - D66

The "SR" series, having a square rail ball bearing system, complement the RB series by providing increased moment load capacities without an increase in profile size. The SR utilizes the same reliable timing belt and pulley drive system found in the RB.

Features: Travel Range: 6.0 meters
Load Capacity: 600 kg
Maximum Speed: 3 meters/sec.
Duty Cycle: 100%
Repeatability: ± 0.2 mm



HLE-Z Series / see pages D67 - D72

The "endless" linear unit is designed for positioning payloads over long travel distances with high rigidity and repeatability. This is accomplished by incorporating Parker's uniquely designed rack-and-pinion based drive system with the "RB" series roller wheel bearing system.

- Features:** Travel Range: 50 meters
Load Capacity: 600 kg
Maximum Speed: 5 meters/sec.
Duty Cycle: 100%
Repeatability: ± 0.05 mm

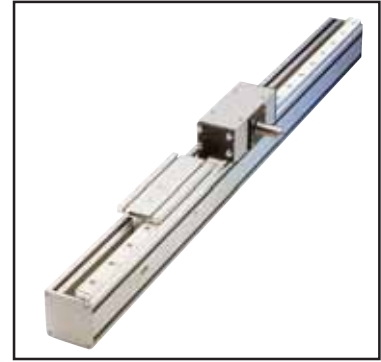

HZR Series / see pages D73 - D78

The HZR is a vertical unit specifically designed to meet the high speed and force requirements of the automation industry. The fixed housing and movable aluminum extrusion permit the unit to retract out of the work area, thereby keeping the work area free of obstructions.

- Features:** Travel Range: 2.0 meters
Load Capacity: 150 kg
Maximum Speed: 5 meters/sec.
Duty Cycle: 100%
Repeatability: ± 0.2 mm



Linear Modules Performance Summary (with standard length carriage)

	HLE60RB	HLE60SR (sq. rail)	HPLA080	HLE100RB	HLE100SR (sq. rail)	HPLA120	HPLA120 (steel wheels)	BLMA	HLE150RB	HLEZ150	HPLA180	HPLA180 (steel wheels)	HPLA180 (Rack&Pinion)
Max. Normal Load, F_z N (lbs)	355(80)	1800(405)	1700(383)	1600(360)	6000(1350)	2700(607)	4100 922)	2700(607)	3400(765)	3400(765)	4700(1057)	15000(3370)	4700(1057)
Max. Side Load, F_y N (lbs)	177(40)	1800(405)	700(157)	785(177)	6000(1350)	800(180)	1300(292)	800(180)	1700(383)	1700(383)	1500(337)	6000(1348)	1500(337)
Max. Force, F_x N (lbs)	665(150)	665(150)	1115(250)	1115(250)	1115(250)	2235(502)	2235(502)	1693(380)	2235(502)	1000 225)	5455(1226)	5455(1226)	1200(270)
Catalog Reference Page	D41	D57	D21	D41	D57	D21	D21	D35	D41	D67	D21	D21	D21

Additional Capabilities / see pages D79 - D84



Rotary Motion Modules



Telescopic Vertical Units



Modular Structures & Supports



Rod Style Electric Cylinders

Accessories:

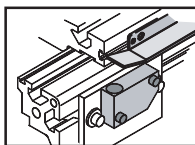

Limit & Home Sensors

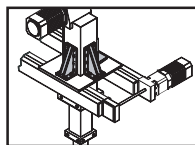

Mounting Brackets & Hardware

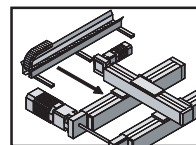

Cable Carriers

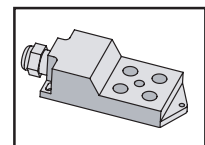

Junction Box

Belt Driven Modules

HPLA Series

Features

- ❑ Strong – steel roller bearings for highest load capacity – 1530 kg
- ❑ Rugged construction for heavy duty applications
- ❑ Thrust force capacity to 5455 N
- ❑ Standard travel up to 9 meters*
- ❑ Velocity up to 5 meters/sec.
- ❑ Positional repeatability of ± 0.2 mm
- ❑ Timing belt and pulley drive mechanism for fast, accurate positioning
- ❑ Optional IP30 rated strip seal

*Longer travels available with splice kits.

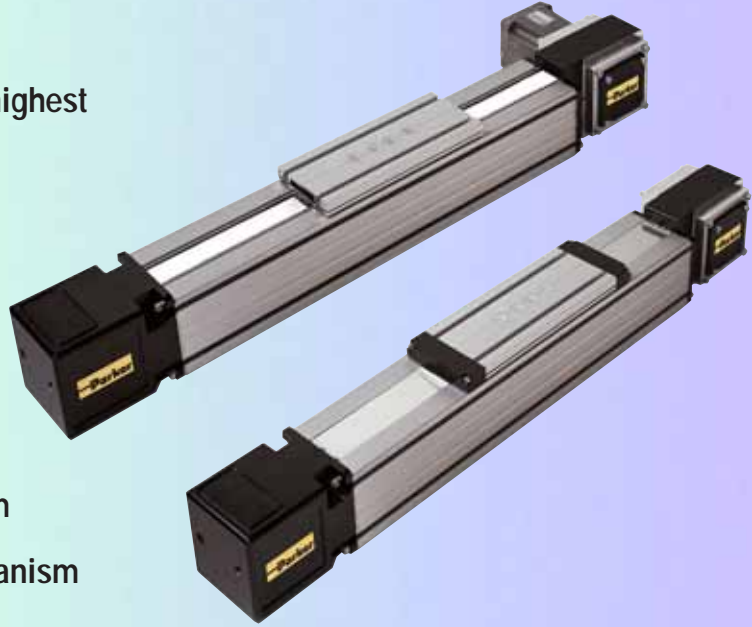

The Modular Concept

Provides the ideal solution for applications:

- **The modular drive system:**
 - increased system stiffness due to larger belt width
 - low maintenance
 - high performance due to hollow shaft input
- **The modular guide system:**
 - provides an alternative to composite wheel material
 - quiet operation
 - low maintenance
 - steel wheel treads option on an integrated steel rolling surface
 - high load-bearing capacity
 - high levels of rigidity
- **Various options for adaptation to wide ranging applications:**
 - steel cover strip
 - corrosion-resistant stainless steel version for application in clean rooms or in the food industry
 - integrated position feedback system for maximum precision

Typical Fields of Application

As part of advanced, cost-effective construction of machines and handling systems:

- **Materials handling:** palletizing, depalletizing, feeding, part removal
- **Cleanroom technology:** water transport, water coating
- **Warehouse technology:** parts picking, storage and retrieval
- **Machine tool automation:** workpiece loading and unloading, tool changing
- **Construction:** formwork, placing reinforcing steel bars in concrete
- **Process engineering:** painting, coating, bonding
- **Testing technology:** guiding ultrasonic sensors, laboratory equipment
- **Textile machinery building:** cross-cutting, slitting and stacking, quilting, seam stitching

Proven Technology

- Direct mounting for planetary gear reducers
- Adjustable “end of travel” limit switches and “Home” position sensor
- Cable carrier systems
- Performance matched Parker servo systems
- Structural components for vertical and multi-axis mounting
- Toe clamps and hardware for fast/easy mounting
- External bumpers
- Link shafts and support bearing for dual unit axes
- Splice plates for extending travels beyond length available in a single profile

HPLA Series

The HPLA is a rugged “next generation” linear module that offers high speed, high acceleration, and long travel, combined with stiff, rigid construction characteristics. It is ideally suited as a single axis product or as a component for high speed multi-axis gantries. The HPLA carriage is rigidly supported on three sides by heavy duty roller bearings, housed in a rugged aluminum housing. The bearing wheels are pre-loaded via eccentric bushings to eliminate play in the system, and are strategically located to evenly distribute the load across the length of the carriage. A high strength drive belt and pulley system provides fast and highly repeatable positioning of the carriage. This high thrust drive belt is securely connected to the carriage by a unique clamping system. This system provides a secure connection and enables easy belt replacement without the need to remove the payload. Having a low coefficient of friction, the carriage design provides a high mechanical efficiency and long service life. Special carriage lengths and linear units with multiple carriages are available for custom applications.

Drive Station

The drive stations are designed to accept planetary gear reducers or provide different shaft outputs for driving the HPLA.

Drive Belt

A zero backlash, steel reinforced timing belt provides high speed, high force, and high acceleration. A serrated clamp mechanism between belt and carriage guarantees a safe, strong connection and allows belt replacement without removing the load.

Carriage

Roller bearing wheels are installed on three sides of the carriage to provide smooth linear motion and support. The wheels are positioned to evenly distribute the load across the length of the carriage. Eccentric bearing wheel bushings are adjusted to eliminate play on all sides of the carriage. The carriages are available in standard and extended lengths.

Tensioning Station

An easily accessible tensioning station is used to set the drive belt tension.

Housing

An extruded aluminum profile provides maximum rigidity (torsion and deflection) at minimum weight. It is designed to accommodate both steel or polyamide roller bearing wheels. The polyamide wheels ride in the extruded guideway and the steel wheels ride on integral hardened steel bearing ways.

Roller Bearing

Three rows of preloaded heavy duty steel roller bearings provide the highest load carrying capability available. Each roller bearing incorporates a low friction, lubricated and sealed radial ball bearing enclosed in a hardened steel outer ring (or raceway). A polyamide tread can be substituted for the steel ring whenever whisper quiet motion is desired.

Optional IP30 Strip Seal

Magnetically attached stainless steel seal strip (not shown in this illustration) provides environmental protection to interior components.

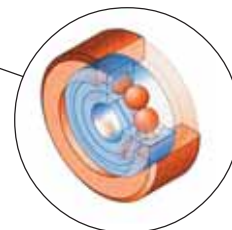
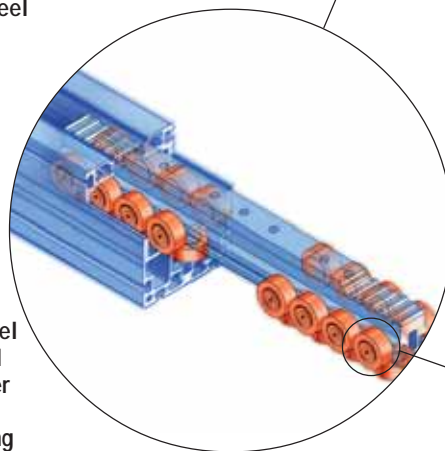
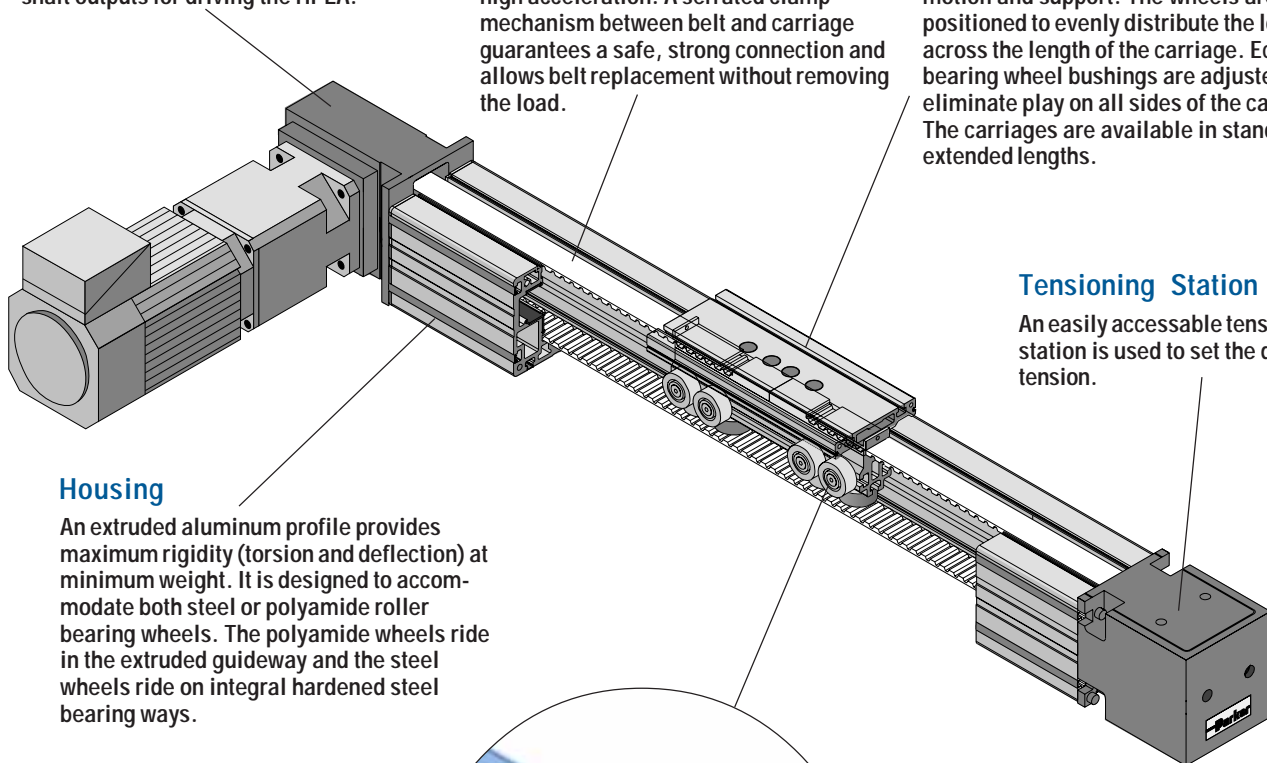

HPLA Series Specifications

Characteristic	Units	HPLA80		HPLA120		HPLA180		HPLA180 (Rack Drive) Polyamide Wheel
		Polyamide Wheel	Steel Wheel	Polyamide Wheel	Steel Wheel	Polyamide Wheel	Steel Wheel	
Unit Weight (basic unit without stroke)								
Standard Carriage, NL	kg(lb)	6.8 (15.0)	7.5 (16.5)	20.2 (44.4)	21.6 (47.5)	57.2 (125.8)	61.6 (135.3)	78.4 (172.5)
Extended Carriage, VL	kg(lb)	8.6 (18.9)	9.5 (20.9)	25.2 (55.4)	27.1 (59.6)	74.8 (164.6)	80.9 (178.0)	95.2 (209.4)
Carriage Weight								
Standard Carriage, NL	kg(lb)	1.7 (3.7)	1.8 (4.0)	5.8 (12.8)	6.0 (13.2)	12.3 (27.1)	12.6 (27.7)	32.5 (71.5) ⁽¹⁾
Extended Carriage, VL	kg(lb)	2.6 (5.7)	2.8 (6.2)	8.8 (19.4)	9.2 (20.2)	21.1 (46.4)	21.8 (48.0)	39.8 (87.6) ⁽¹⁾
Weight/meter of additional travel	kg/m(lb/ft)	6.1 (13.7)	7.3 (16.1)	13.7 (30.1)	15.5 (34.1)	29.4 (64.7)	33.6 (73.9)	31.5 (69.3)
Moment of Inertia (related to the drive shaft)								
Standard Carriage, NL	kg-cm ² (lb-in ²)	17.8 (6.1)	18.4 (6.3)	142 (48)	146 (50)	725 (247)	743 (253)	698 (238)
Extended Carriage, VL	kg-cm ² (lb-in ²)	25.4 (8.7)	26.5 (9.0)	197 (67)	204 (70)	1121 (382)	1154 (393)	845 (288)
Travel and Speed								
Maximum Speed ⁽²⁾	m/s(in/s)	5 (200)		5 (200)		5 (200)		5.0 (200)
Maximum Acceleration ⁽²⁾	m/s ² (in/s ²)	10 (393)		10 (393)		10 (393)		10.0 (393)
Max. Travel, standard carriage NL ⁽³⁾	mm(in)	5540 (218)	5520 (217)	9470 (372)	9440 (371)	9240 (363)	9200 (362)	8680 (341)
Max. Travel, extended carriage VL ⁽³⁾	mm(in)	5390 (212)	5370 (211)	9270 (365)	9240 (363)	8940 (352)	8900 (350)	8380 (330)
Geometric Data								
Cross Section, Square	mm(in)	80 (3.15)		120 (4.72)		180 (7.09)		180 (7.09)
Moment of Inertia I _x	cm ⁴ (in ⁴)	139 (3.34)		724 (17.39)		3610 (86.73)		3610 (86.73)
Moment of Inertia I _y	cm ⁴ (in ⁴)	165 (3.96)		830 (19.94)		4077 (97.95)		4077 (97.95)
Moment of Elasticity	N/mm ² (lb/in ²)	0.72 x 10 ⁵ (0.1044 x 10 ⁸)		0.72 x 10 ⁵ (0.1044 x 10 ⁸)		0.72 x 10 ⁵ (0.1044 x 10 ⁸)		0.72 x 10 ⁵ (0.1044 x 10 ⁸)
Pulley Data, Torques, Forces								
Travel Distance per Revolution	mm/rev(in/rev)	180 (709)		270 (10.63)		420 (16.54)		280 (11.02)
Response Radius of Drive Pulley	mm(in)	28.7 (1.13)		43.0 (1.69)		66.8 (2.63)		44.6 (1.75)
Maximum Drive Torque	Nm(lb-in)	47.4 (420)		131.4 (1165)		368 (3264)		58 (514)
Maximum Belt Traction (effective load)	N(lb)	Refer to charts on following pages						
Repeatability ⁽³⁾⁽⁴⁾	mm(in)	± 0.2 (± 0.008)		± 0.2 (± 0.008)		± 0.2 (± 0.008)		± 0.05 (± 0.002)

(1) Includes weight of drive module
 (2) Greater speeds and accelerations may be achieved
 (3) Bumper to bumper maximum stroke - splicing possible for longer travel distances
 (4) Nominal value - component dependent. For improved repeatability consult factory.

Linear Actuator
Size Comparison

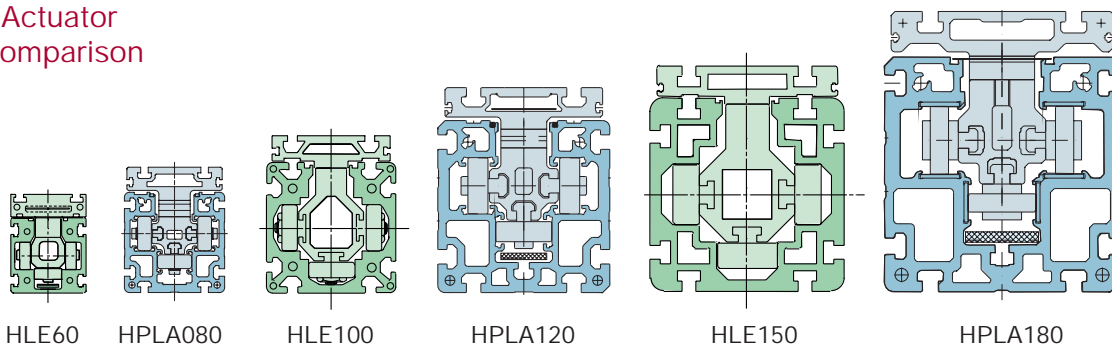

HPLA080 Series – Load-bearing capacity of carriage and timing belt

The forces and moments that the carriage is capable of transferring are speed-dependent. The curves shown in the graphs apply to a standard carriage (S). With the extended carriage (E), all the values apart from F_x (load-bearing capacity of timing belt) can be doubled if the load is applied equally to both halves of the carriage

or distributed uniformly along its entire length.

The curves show the maximum load-bearing capacity of a carriage in one direction of force or torque. If several loads are applied in different directions, the values given by the curves must be derated, i.e. the load or speed should be reduced if necessary.

The software package "DimAxes" is available for determination of precise carriage loading. Visit www.parkermotion.com to request a Gantry Robot CD.

Load-bearing capacity of HPLA080 timing belt (F_x)

Drive Option	Transferrable Thrust Force (N)	
	Nominal Belt Tension (81,000 km life)	Maximum Belt Tension (46,000 km life)
Supported Pulley(S03,S04,S08,S09)	925	1115
Unsupported Pulley(S01,S02) W/GTN090 or PEN115 PEN090	675	900
	500	665

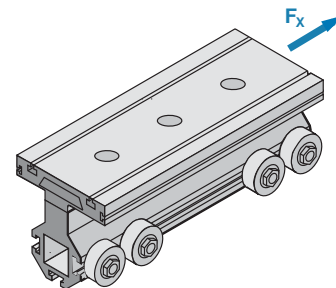

Load-bearing capacity of HPLA080 (F_y and F_z) (Values double for extended carriage)

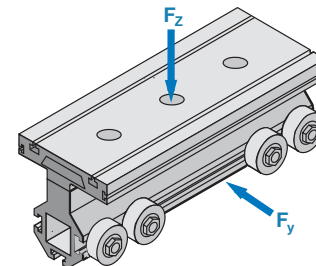
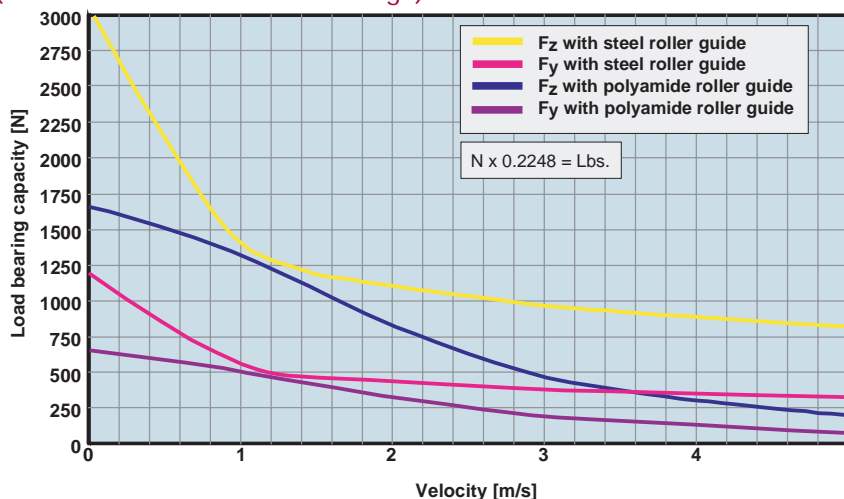

Maximum permissible Moment Load - HPLA080 (M_x , M_y and M_z) (Values double for extended carriage)

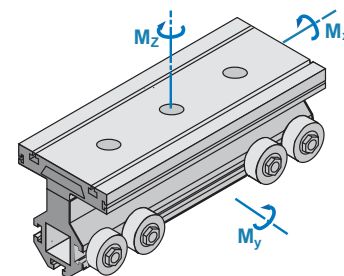
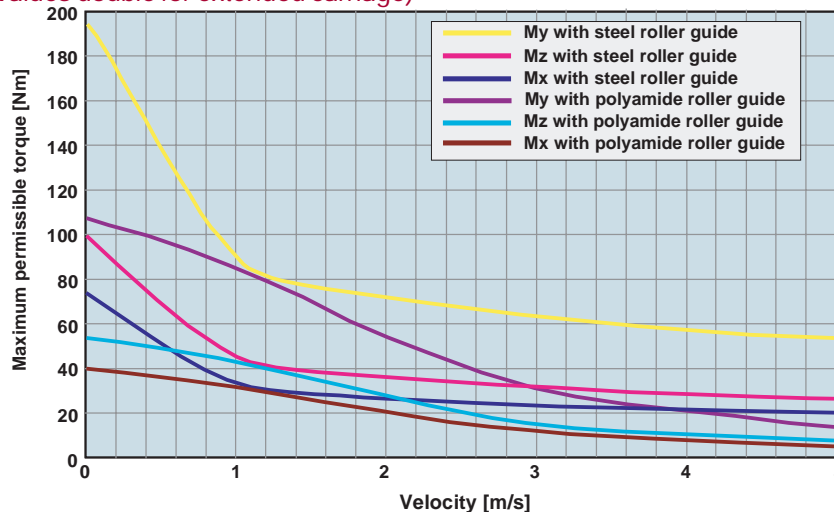

HPLA120 Series – Load-bearing capacity of carriage and timing belt

Load-bearing capacity of HPLA120 timing belt (F_x)

Drive Option	Transferrable Thrust Force (N)	
	Nominal Belt Tension (85,000 km life)	Maximum Belt Tension (37,000 km life)
Supported Pulley (S03,S04,S08,S09)	1700	2235
Unsupported Pulley(S01,S02) W/N115	1515	2015
W/GTN090 or PEN115	675	900

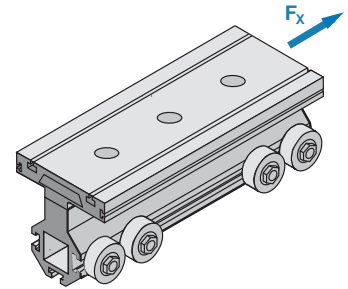

Load-bearing capacity of HPLA120 (F_y and F_z)
(Values double for extended carriage)

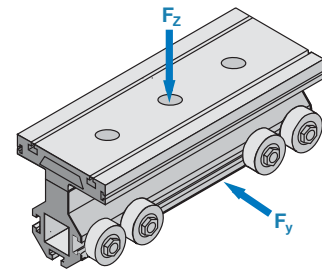
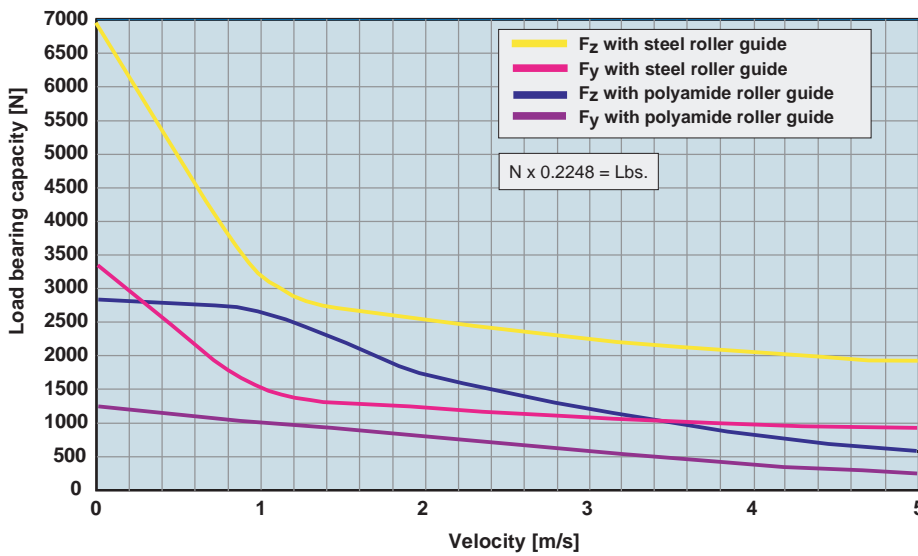

Maximum permissible Moment Load - HPLA120 (M_x , M_y and M_z)
(Values double for extended carriage)

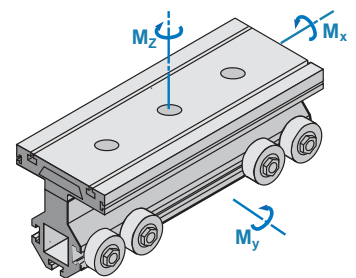
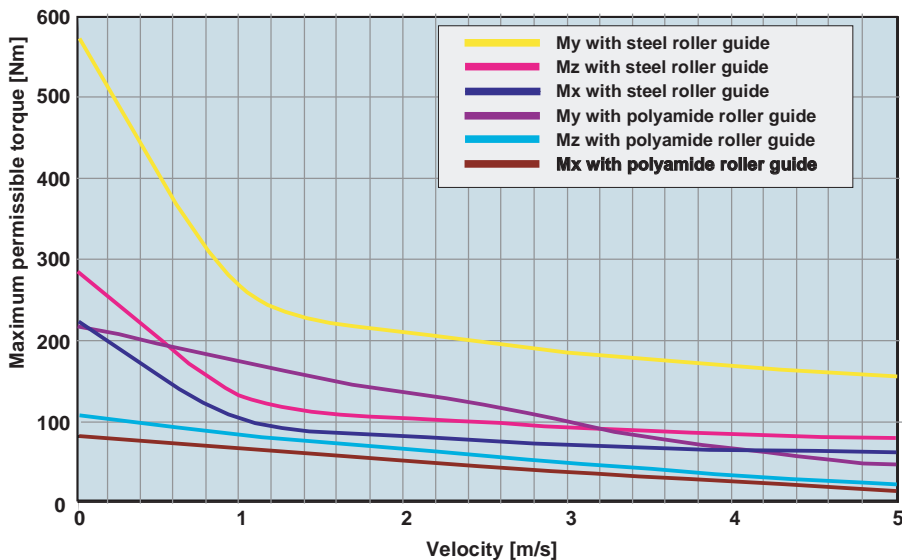

HPLA180 Series – Load-bearing capacity of carriage and timing belt

Load-bearing capacity of HPLA180 timing belt (F_x)

Drive Option	Transferrable Thrust Force (N)	
	Nominal Belt Tension (100,000 km life)	Maximum Belt Tension (45,000 km life)
Supported Pulley (S03,S04),(S08),(S09)	4170	5455
Unsupported Pulley(S01,S02) W/GTN142	1405	1804
	W/GTN115	1065

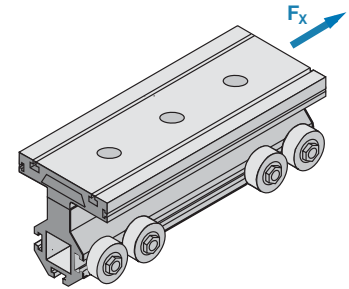

Load-bearing capacity of HPLA180 (F_y and F_z)

(Values double for extended carriage)

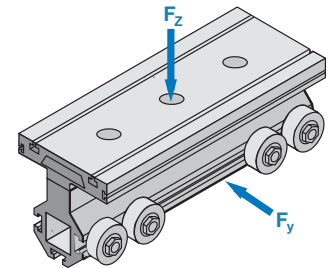
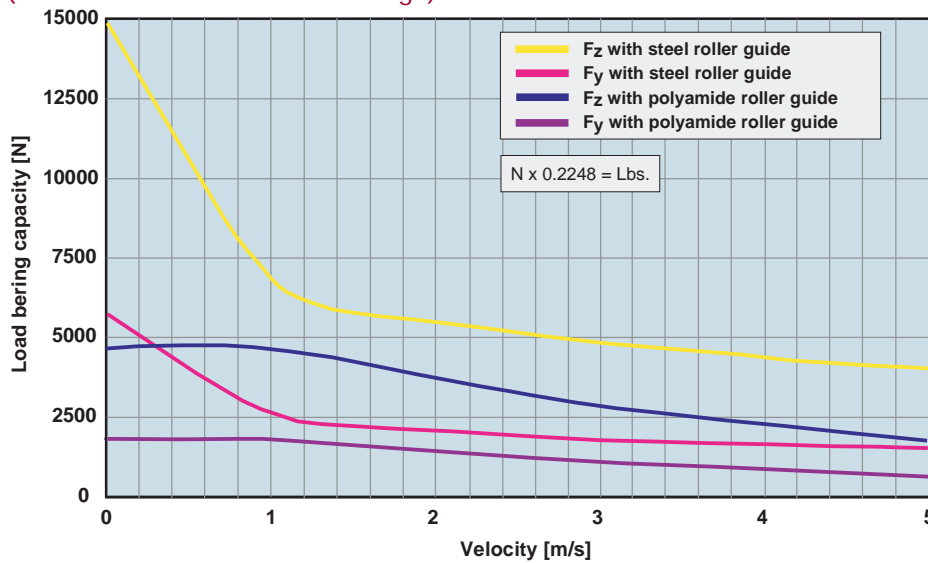

Maximum permissible Moment Load - HPLA180 (M_x , M_y and M_z)

(Values double for extended carriage)

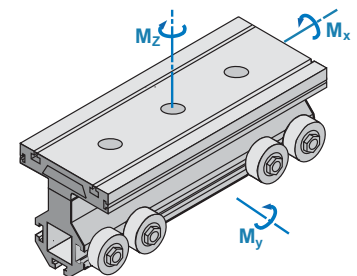
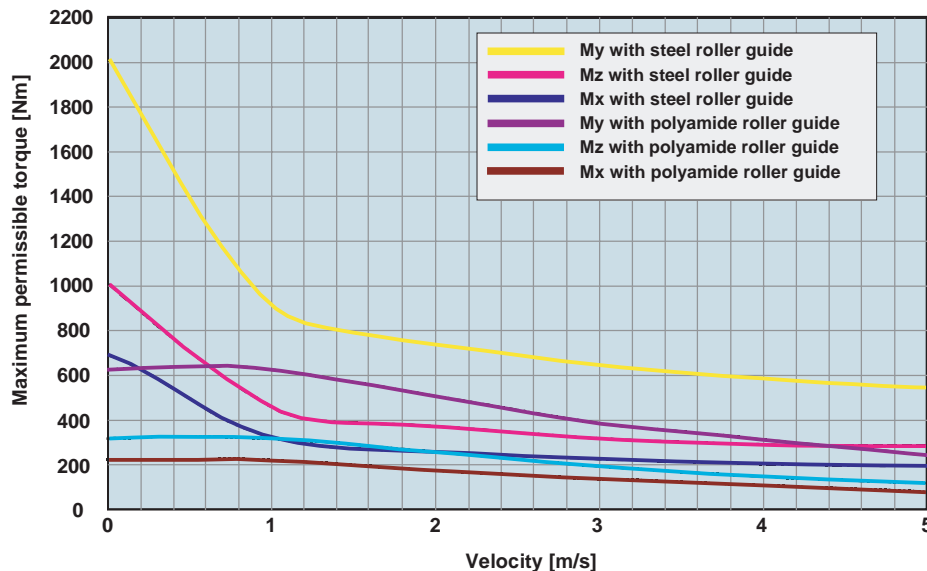

Belt Driven Modules

HPLA Characteristics

The HPLA deflection curves can be used for determining the deflection based on the profile length and the application load weight. Applications requiring high acceleration forces can place a severe strain on the system stability. In these cases, a solid substructure may be required with the HPLA product being supported at frequent intervals.

These deflection curves illustrate the deflection f , based on the HPLA profile being simply supported at both ends. The graphs take into consideration the self deflection due to the weight of the profile, along with the load to be transported. The maximum deflection cannot be exceeded. If the maximum deflec-

tion is exceeded based on your application parameters, then additional supports are required. Alternatively, the next larger profile size may be considered. For deflection formulas and calculations, please refer to the Technical Information Library found on our web site: www.parkermotion.com

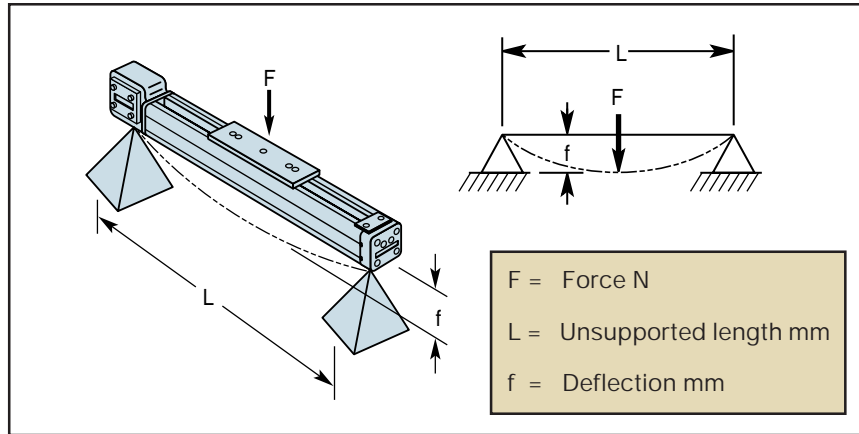

HPLA080 Deflection Curve

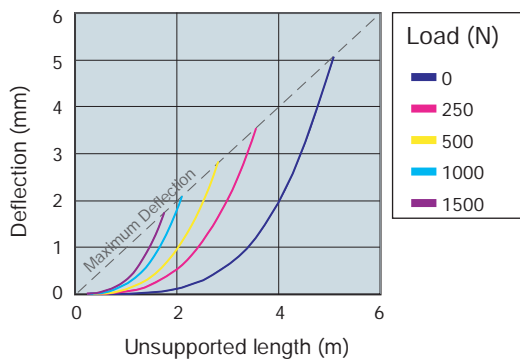

HPLA120 Deflection Curve

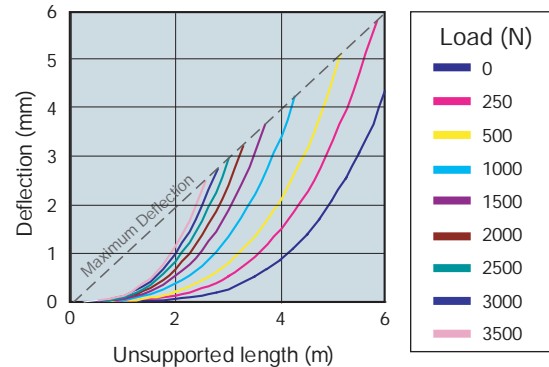

HPLA180 Deflection

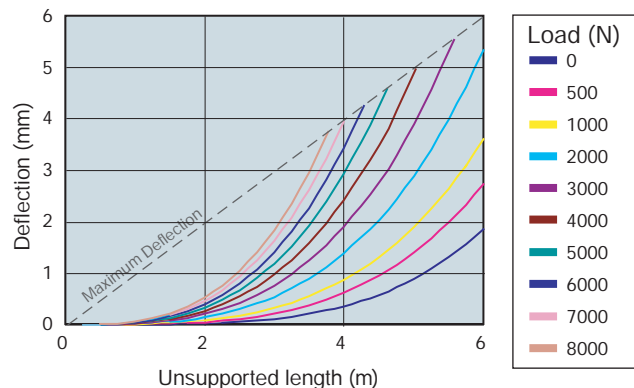

Dual Axis Considerations

When two parallel linear modules are required to form a single axis, the span or distance between each unit determines which type of shaft connection is required. In some cases, a link shaft support bearing might also be required.

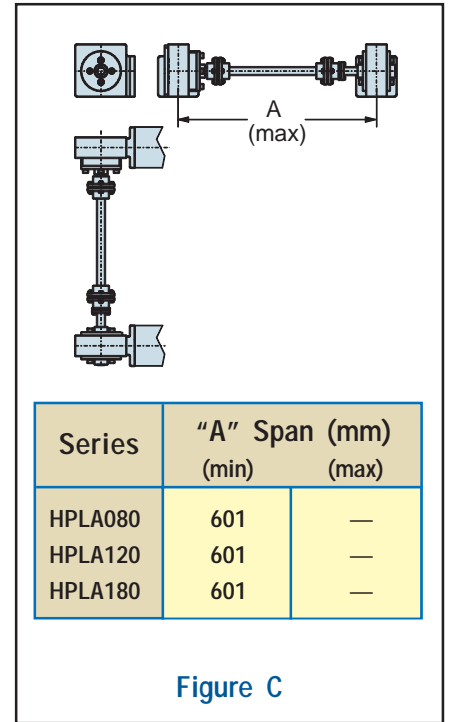
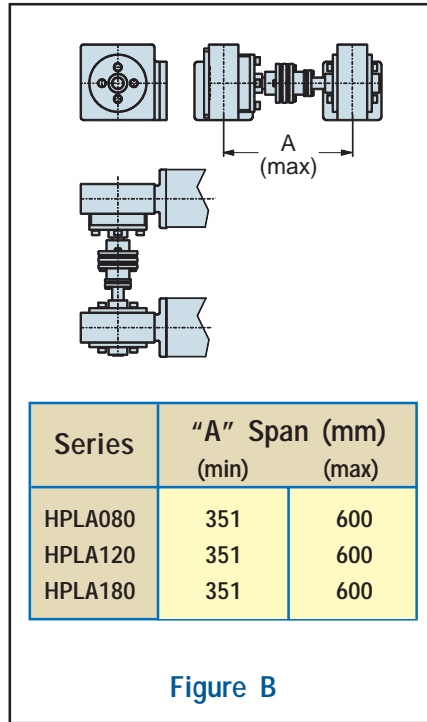
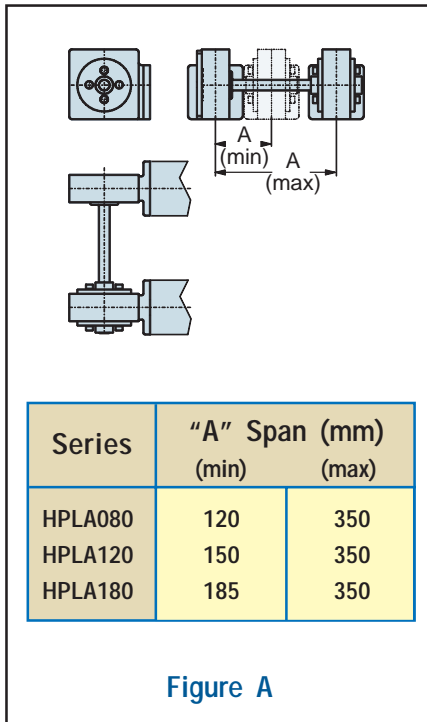

The link shaft bearing is used to support the linking shaft of an HPLA dual axis when there is a large center to center distance. This bearing must be used if the critical speed is exceeded with the dual-axis link shaft.

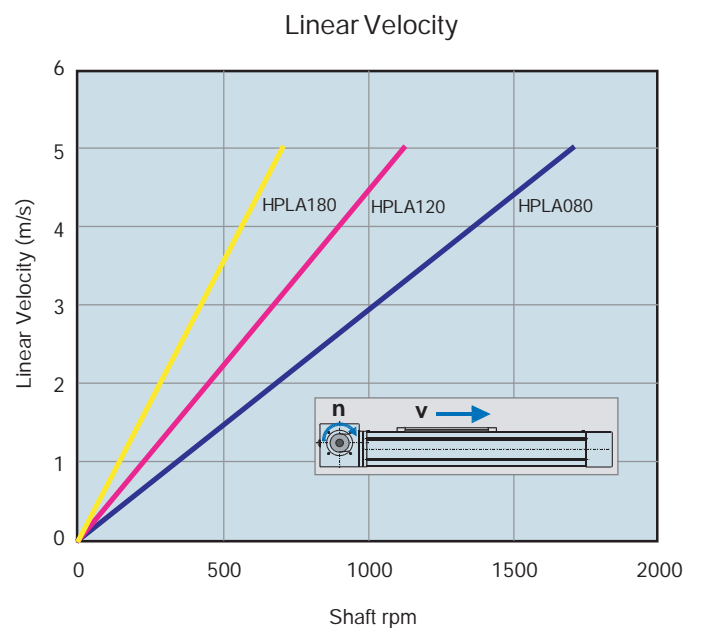
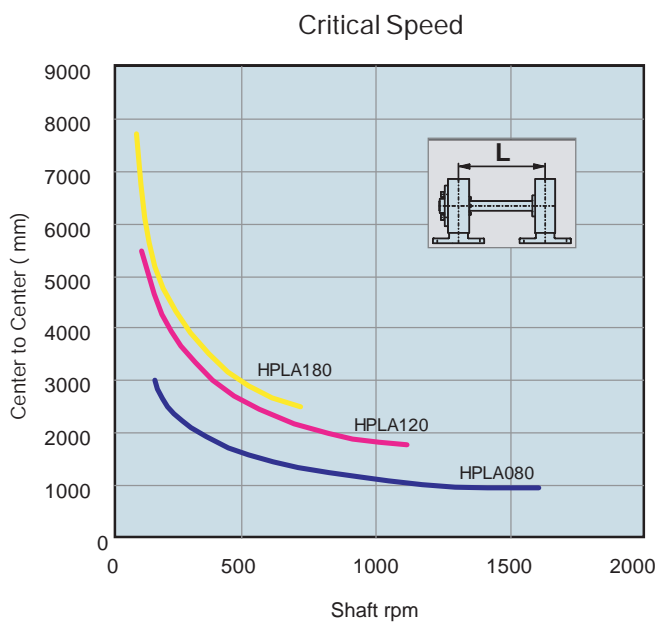

HPLA080 Dimensions (mm)

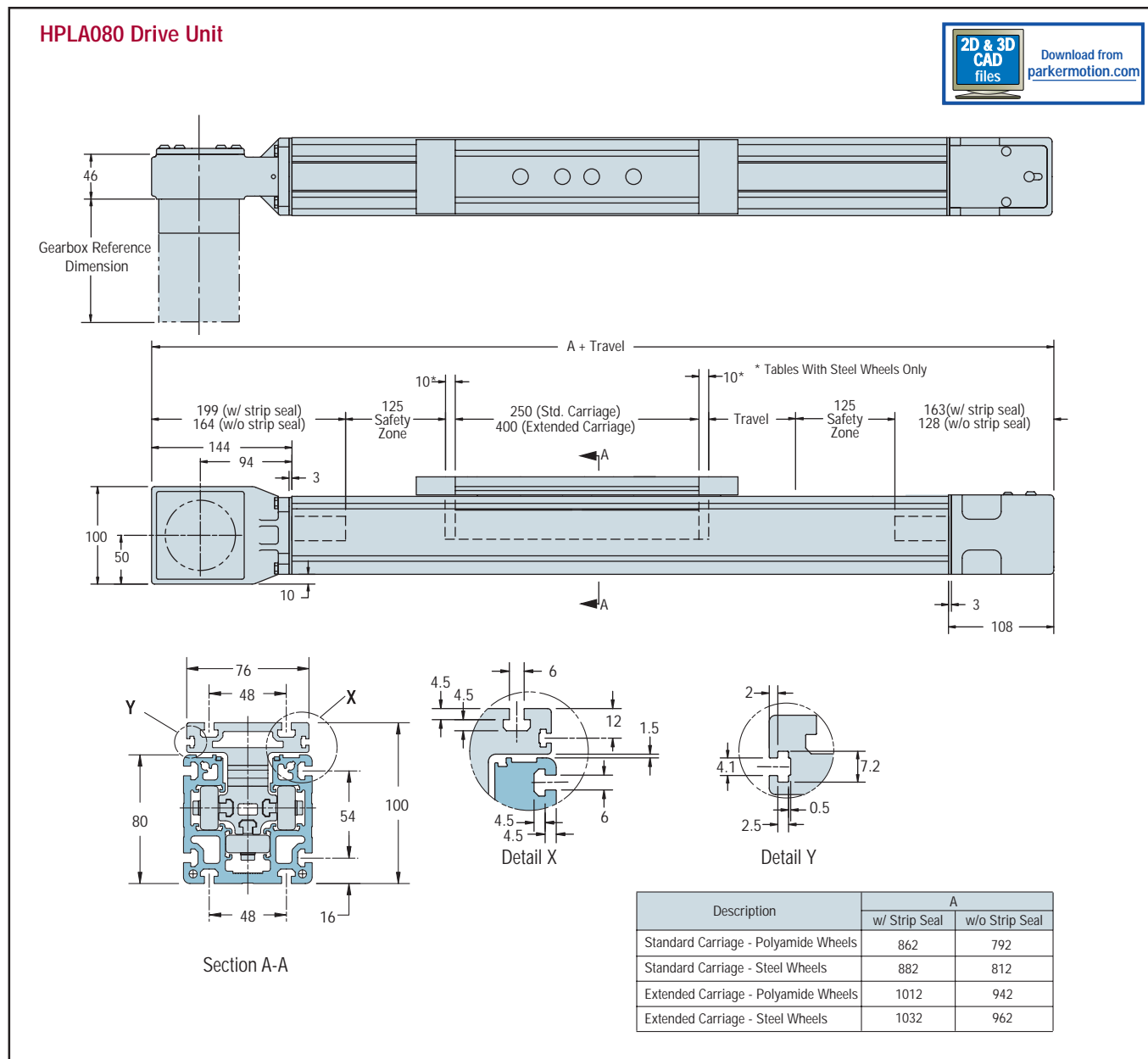

HPLA120 Dimensions (mm)

HPLA120 Drive Unit

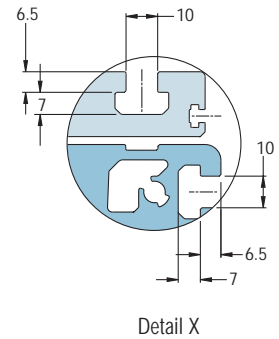
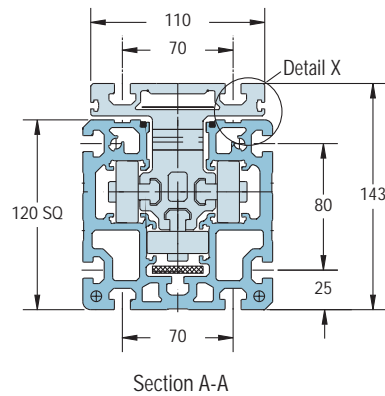
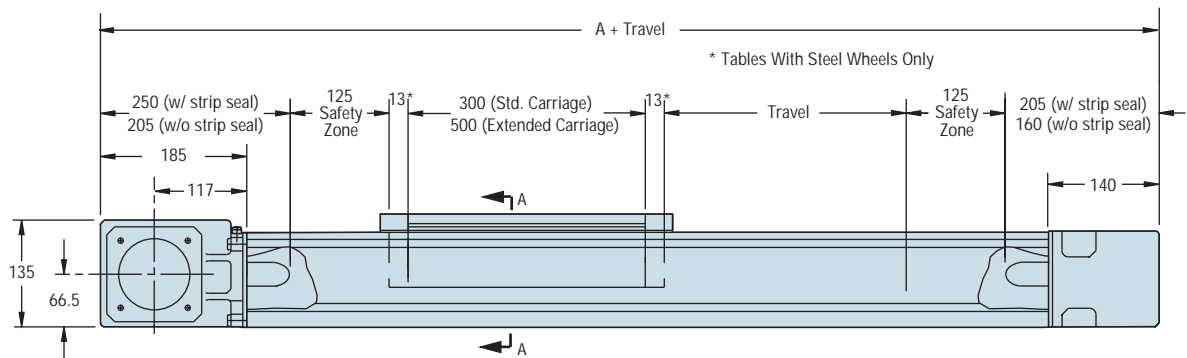
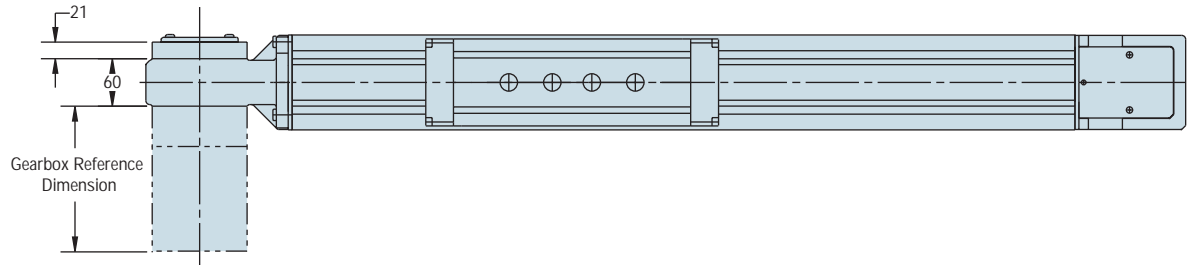

Description	A	
	w/ Strip Seal	w/o Strip Seal
Standard Carriage - Polyamide Wheels	1005	915
Standard Carriage - Steel Wheels	1031	941
Extended Carriage - Polyamide Wheels	1205	1115
Extended Carriage - Steel Wheels	1231	1141

Belt Driven Modules

HPLA 180 Dimensions (mm)

HPLA180 Drive Unit

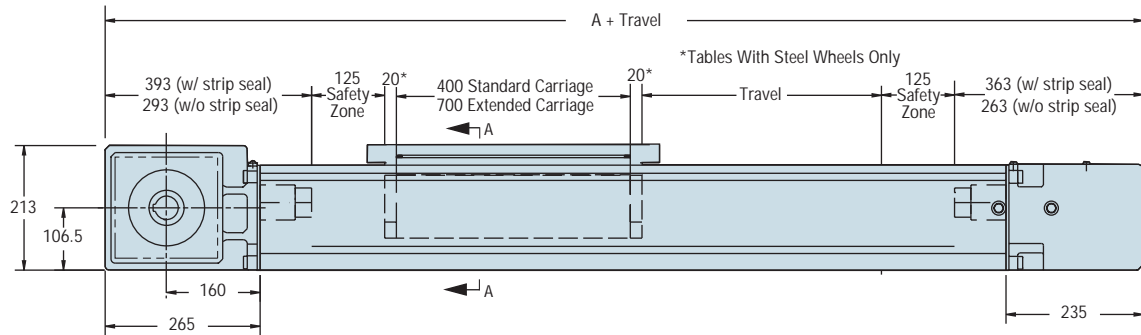
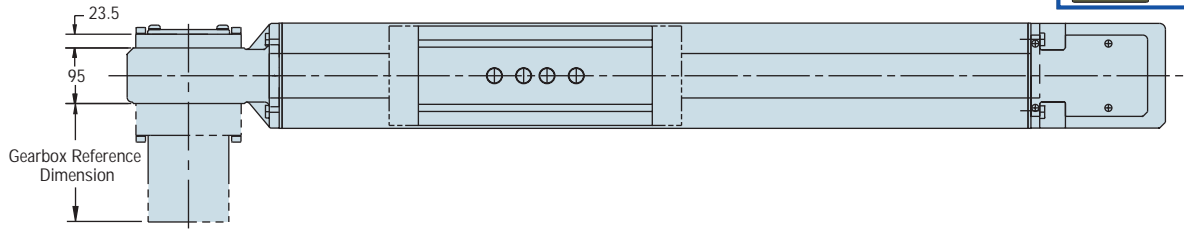

Description	A	
	w/ Strip Seal	w/o Strip Seal
Standard Carriage - Polyamide Wheels	1406	1206
Standard Carriage - Steel Wheels	1446	1246
Extended Carriage - Polyamide Wheels	1706	1506
Extended Carriage - Steel Wheels	1746	1546

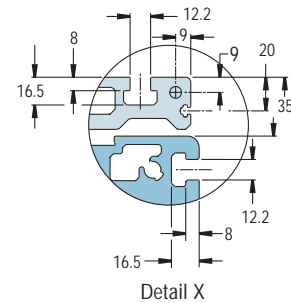
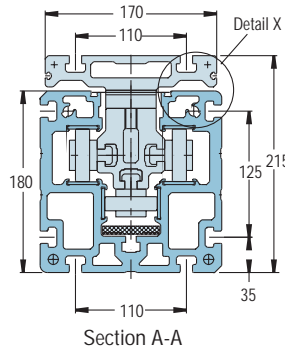

HPLA180 Rack Drive Unit

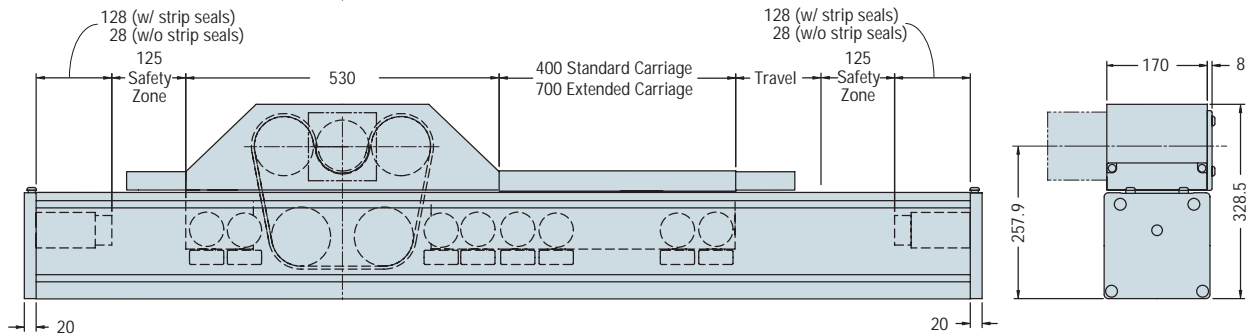
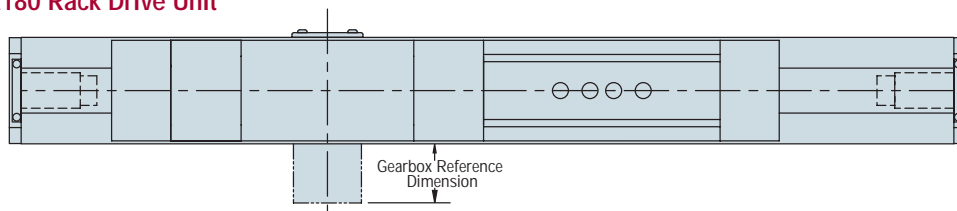

HPLA Idler Unit Dimensions (mm)

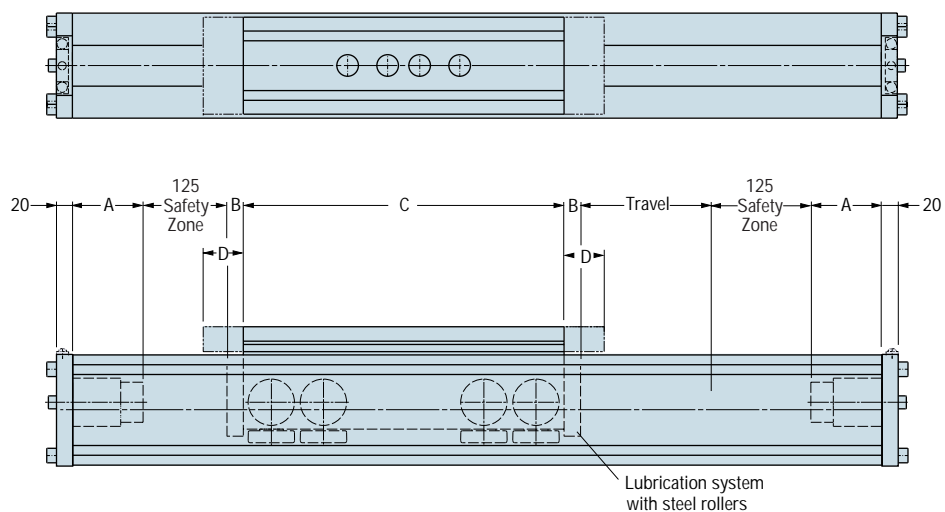

Type	Carriage Length	Wheel Type	Without Strip Seal Cover					With Strip Seal Cover				
			A	B	C	D	E	A	B	C	D	E
HPLA080	Standard	Polyamide	20	-	250	-	10	55	-	250	40	10
HPLA080	Extended	Polyamide	20	-	400	-	10	55	-	400	40	10
HPLA080	Standard	Steel	20	10	250	-	10	55	10	250	40	10
HPLA080	Extended	Steel	20	10	400	-	10	55	10	400	40	10
HPLA120	Standard	Polyamide	20	-	300	-	15	65	-	300	50	15
HPLA120	Extended	Polyamide	20	-	500	-	15	65	-	500	50	15
HPLA120	Standard	Steel	20	13	300	-	15	65	13	300	50	15
HPLA120	Extended	Steel	20	13	500	-	15	65	13	500	50	15
HPLA180	Standard	Polyamide	28	-	400	-	20	128	-	400	100	20
HPLA180	Extended	Polyamide	28	-	700	-	20	128	-	700	100	20
HPLA180	Standard	Steel	28	20	400	-	20	128	20	400	100	20
HPLA180	Extended	Steel	28	20	700	-	20	128	20	700	100	20

Belt Driven Modules

HPLA Series How to Order

Order Example: **HPLA** **080** **D1** **B1** **T2000** **C1** **DA1000** **S08** **F02**

Model Series **HPLA**

Type

080 **080**

120 **120**

180 **180**

Drive System

Idle Unit **D0**

Timing Belt Drive, Nominal Thrust, Maximum Life **D1**

Timing Belt Drive, Maximum Thrust, Nominal Life **D2**

Internal Rack and Pinion (HPLA 180 only) **D9**

Bearing Option

Polyamide Rollers **B1**

Steel Rollers **B2**

Travel

Specify Desired Travel (mm) **Tnnnn**

Carriage

Standard Length Carriage with Load Plate **C1**

Extended Length Carriage with Load Plate **C2**

Standard Length Carriage with Clamping Bar **C3**

Extended Length Carriage with Clamping Bar **C4**

Link Shaft Option

Single Axis or idler unit - No Link Shaft **DA0000**

Double Unit - Specify Center to Center Distance(mm)..... **DAAnnn**

Drive Shaft Configurations

No Shaft - Idler Unit **S00**

Unsupported Pulley - Flange Left **S01**

Unsupported Pulley - Flange Right **S02**

Supported Pulley - Flange Left **S03**

Supported Pulley - Flange Right **S04**

Supported Pulley - Shaft Option - Left **S05**

Supported Pulley - Shaft Option - Right **S06**

Supported Pulley - Shaft Option - Both **S07**

Supported Pulley - Flange Left - Shaft Right **S08**

Supported Pulley - Flange Right - Shaft Left **S09**

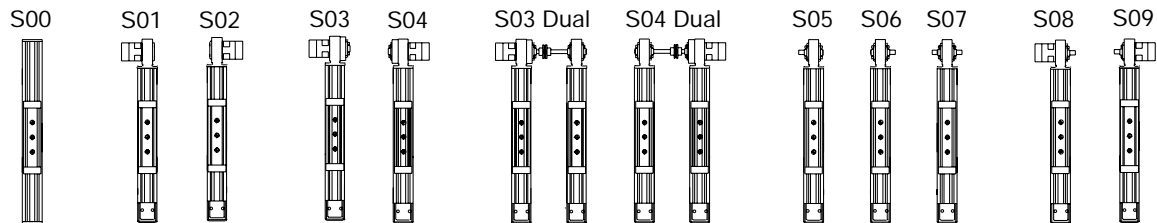

Drive Housing Flange

No Flange **F00**

GTN070 Flange (HPLA080 only) **F01**

GTN090 Flange (HPLA080 & HPLA120 only) **F02**

GTN115 Flange (HPLA120 & HPLA180 only) **F03**

GTN142 Flange (HPLA180 only) **F04**

PEN090 Flange (HPLA080 only) **F06**

PEN115 Flange (HPLA080 & HPLA120 only) **F07**



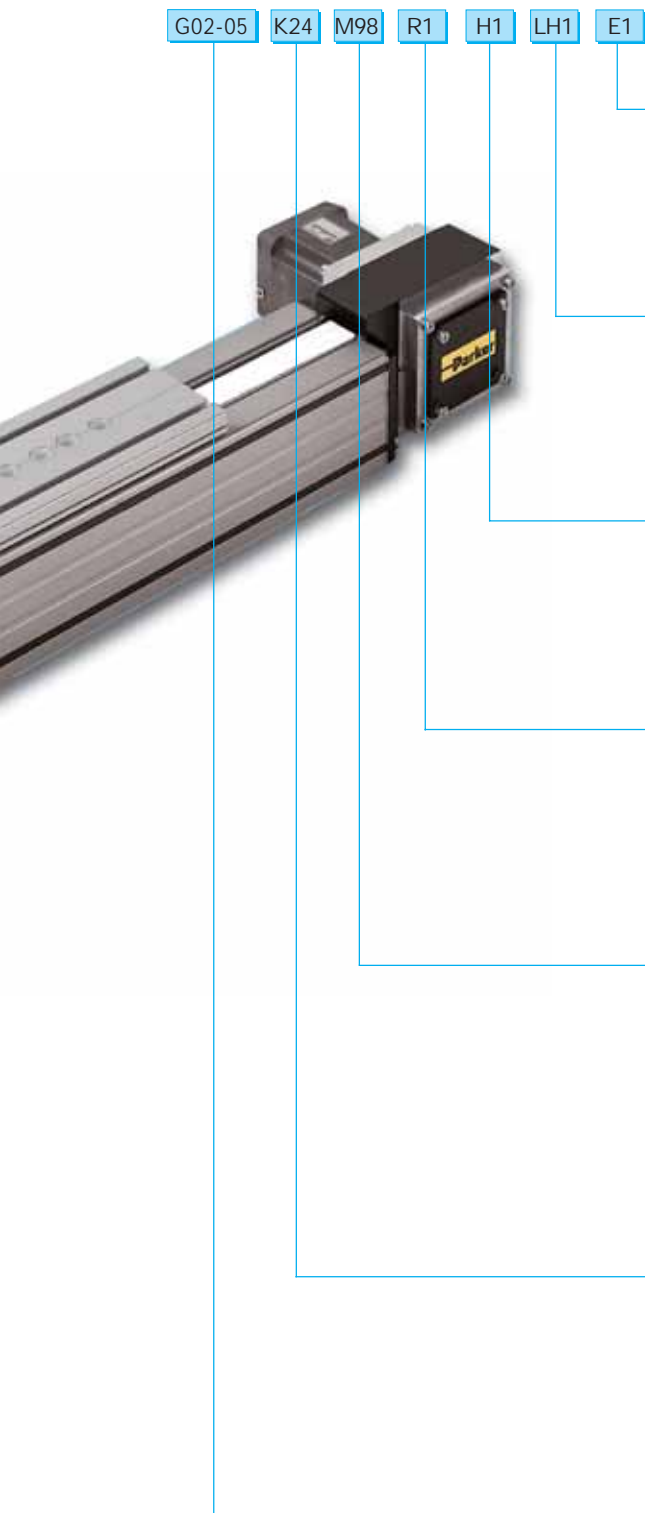

Linear Encoder

- E1** Without linear encoder
- E5** 5.0 micron Resolution - Magnetic Type
- E7** Sine Cosine Output - Magnetic Type

Limit/Home Switch Option

- LH0** No Home/Limits
- LH1** Three Mechanical Switches
- LH2** Two Mechanical Switches, One proximity (NPN)
- LH3** Three NPN Prox Switches, 10-30 VDC
- LH4** Three PNP Prox Switches, 10-30 VDC

Mounting Orientation

- H1** Carriage up
- H2** Carriage down
- H3** Carriage on side, drive station up
- H4** Carriage on side, drive station down

Environmental Option

- R1** Standard preparation with strip seal
- R2** Standard preparation with no strip seal
- R3** Corrosion resistant preparation with strip seal
- R4** Corrosion resistant preparation with no strip seal

Motor Mount Option

- M00** No Motor
- M98** Mount Parker motor
- M99** Mount customer motor (consult factory)

Motor Kit

- | | |
|---|---|
| K00 No Flange | K27 SMN100 |
| K20 NEMA23 stepper - 1/4" shaft | K28 NEMA42 stepper - 5/8" shaft |
| K21 BE23 | K29 MPM114x (x=0,1 metric) |
| K22 MPM66 (metric) | K30 SMN115, MPM114x (x=2,3 metric) |
| K23 SMN60,MPM72 (metric), N070, J070 | K31 SMN142, MPM142x (x=0,1,2 metric) |
| K24 SMN82,MPM89 (metric), N092, J092 | K32 MPM142x (x=3,4 metric) |
| K25 NEMA34 stepper - 3/8" shaft | K33 MPM190x (x=0,1,2 metric) |
| K26 BE34 | |

Gearbox Option

- | | |
|--------------------------|------------------------|
| G00-00 No Gearbox | G04-nn GTN142* |
| G01-nn GTN070* | G06-nn PEN090** |
| G02-nn GTN090* | G07-nn PEN115** |
| G03-nn GTN115* | |

* Single stage ratios: 3,4,5,8,10; Dual stage ratios: 12,15,16,20,25

** Single stage ratios: 3,4,5,8; Dual stage ratios: 9,12,15,16,20,25

BLMA Linear Motor Driven Module

Features

- ❑ Linear Servo Motor Drive
- ❑ $\pm 10.0 \mu\text{m}$ positional repeatability
- ❑ Velocity up to 7 meters/sec.
- ❑ Acceleration to 5 g's
- ❑ IP30 seal strip
- ❑ Standard travels to 6 meters

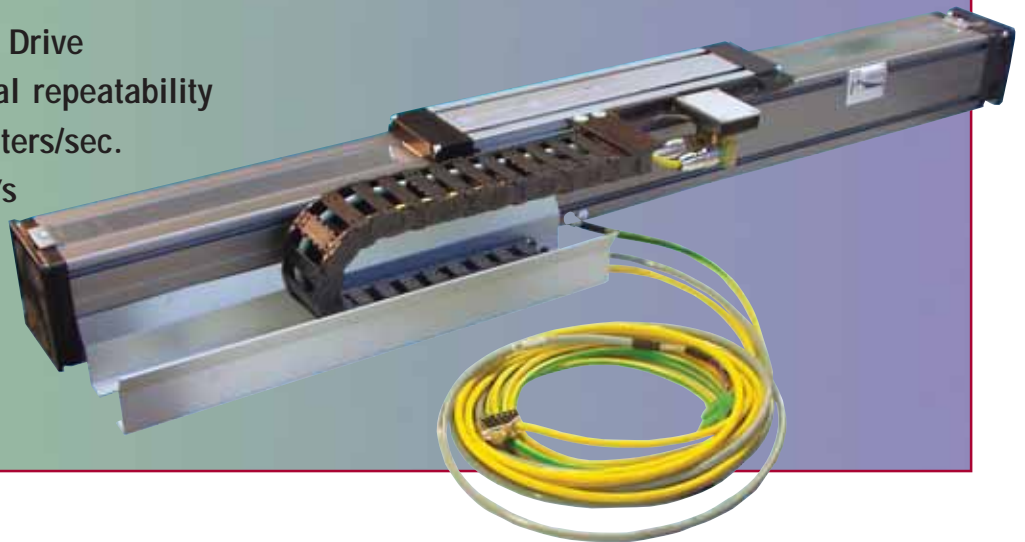

Principle of Operation

Parker's BLMA120 linear servo motor actuator offers high end, direct drive performance to the industrial actuator world for material handling and similar applications that require higher accelerations, higher speeds, instant settling, and precise positioning over long travels. (BLMA = Balanced Linear Motor Actuator). The BLMA is a plug and play linear motor actuator which houses a powerful linear servo motor (380 pounds of peak thrust) in a high strength rigid aluminum body to enable high end performance over long unsupported spans.

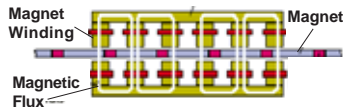

In principle, a linear servo motor operates much like an "unwound" rotary servo motor. In the BLMA, the row of magnets is arranged perpendicular to the axis of motion along the entire length of stroke. The forcer, which corresponds to the stator in a rotary motor, is situated in the bearing carriage of the linear module. Its coil windings are located on both sides of the row of magnets, which allows for the balancing of magnetic force. This balancing effect relieves the bearing carriage of the magnetic forces, leaving only the external loads to account for. The forcer is available in a 12 pole and 20 pole version to accommodate different linear force requirements.

The direct, non-contact drive design eliminates the need for mechanical transmission components, particularly the need for a coupling from a rotary motor to a linear transmission device, such as a lead screw. This feature carries several advantages:

- A low system mass moment of inertia, and as a result high acceleration and speed capability.
- The elimination of losses due to mechanics means higher system accuracy.
- Stiffness is improved through the elimination of mechanical components and their inherent sloppiness.
- Long service life, as there is no mechanical wear associated with the non-contact transmission of force.
- Quiet operation.

The external dimensions of the BLMA are identical to those of the belt-driven HPLA120, making it easy to combine with other Parker linear drive products. The linear motor is completely internal, and an IP30 steel strip seal protects the linear motor from dust and debris. An integrated SinCos linear encoder ensures the highest repeatability. The linear bearing system consists of proven polyamide-covered roller bearing wheels that are lubricated for life. Wheel play is eliminated through the use of eccentric adjustments on all sides. Two mounting grooves reside on both sides and on the underside of the bearing extrusion. The grooves allow the mounting of additional mechanical components as well as additional linear motion axes. Additional forcer-carriages on a single axis are possible.

Typical Applications

Linear motor-driven modules are particularly effective where travel times must be minimized in order to improve throughput and productivity. Higher accelerations, higher speeds and the precise positioning of small to mid-sized loads enable:

- On- and off loading of metal sheets into high speed forming presses.
- Precise application and dispensing of adhesives or sealants onto large work areas. The higher dynamics and accuracy of the BLMA enable the machine to optimize contours and achieve consistent dispensing rates.
- Installation of plates into paper and printing machines for large-format paper.

BLMA Series Specifications

Motor Data			12 Pole				20 Pole			
			Series		Parallel		Series		Parallel	
			Polyamide Wheels	Steel Wheels	Polyamide Wheels	Steel Wheels	Polyamide Wheels	Steel Wheels	Polyamide Wheels	Steel Wheels
Continuous Force, Water Cooled	N (lb)	419(94)	520(117)	419(94)	520(117)	689(155)	844(190)	689(155)	844(190)	
Continuous Current, Water Cooled	A	6.5	8.0	13.0	16.1	11.9	14.6	23.8	29.1	
Continuous Force, Air Cooled	N (lb)	310(70)	385(87)	310(70)	385(87)	510(115)	625 (141)	510(115)	625(141)	
Continuous Current, Air Cooled	A	4.8	6.0	9.6	11.9	8.8	10.8	17.6	21.6	
Peak Force	N (lb)	892(200)	892(200)	892(200)	892(200)	1693(380)	1693(380)	1693(380)	1693(380)	
Peak Current	A	16.8	16.8	33.6	33.6	30.8	30.8	61.6	61.6	
Resistance	Ohm	4.2	4.2	1.05	1.05	2.8	2.8	0.7	0.7	
Inductance	mH	23.85	23.85	5.96	5.96	13.09	13.09	3.27	3.27	
Back EMF	V/m/s (V/in/s)	59(1.5)	59(1.5)	30(0.8)	30(0.8)	59(1.5)	59(1.5)	30(0.8)	30(0.8)	
Resolver Offset	degrees	58	58	58	58	58	58	58	58	
Max. Coil Temperature	°C	90	130	90	130	90	130	90	130	
Carriage Temperature	°C	55	75	55	75	65	95	65	95	
Magnetic Pitch Motor	mm (in)	42(1.654)	42(1.654)	42(1.654)	42(1.654)	42(1.654)	42(1.654)	42(1.654)	42(1.654)	
Feedback	-	SinCos	SinCos	SinCos	SinCos	SinCos	SinCos	SinCos	SinCos	
Magnetic Pitch (feedback)	mm (in)	1(.0394)	1(.0394)	1(.0394)	1(.0394)	1(.0394)	1(.0394)	1(.0394)	1(.0394)	
Time at Peak current	sec	5	5	5	5	5	5	5	5	
Recommended Compax 3 Power Level*		S063V2 or S075V4		S150V4		S150V4		S300V4		

*Refer to page D40 for Compax 3 Drive Information

Table Data			12 Pole				20 Pole			
			Series		Parallel		Series		Parallel	
			Polyamide Wheels	Steel Wheels	Polyamide Wheels	Steel Wheels	Polyamide Wheels	Steel Wheels	Polyamide Wheels	Steel Wheels
Nominal Speed	m/s (in/s)	5 (200)		5 (200)		5 (200)		5 (200)		
Peak Speed	m/s	7 (280)		7 (280)		7 (280)		7 (280)		
Nominal Acceleration	m/s ² (in/s ²)	20 (786)		20 (786)		20 (786)		20 (786)		
Peak Acceleration	m/s ² (in/s ²)	50 (1965)		50 (1965)		50 (1965)		50 (1965)		
Carriage Length	mm (in)	515 (20.3)	45 (21.5)	695 (27.4)	725 (28.5)	680 (26.8)	710 (28.0)	860 (33.9)	890 (35.0)	
Maximum Stroke	mm (in)	6329 (249)	6299 (248)	6149 (242)	6119 (240)	6164 (242)	6134 (241)	5984 (235)	5954 (234)	
Carriage Weight	kg (lb)	11.6 (25.5)		14.2 (31.2)		16.3 (35.9)		18.9 (41.6)		
Weight of Base Unit	kg (lb)	25.7 (56.5)		27.9 (61.4)		32.8 (72.2)		35.0 (77.0)		
Static Friction	N	30 (6.7)		30 (6.7)		30 (6.7)		30 (6.7)		
Damping	N/m/s (lb/in/s)	15 (0.086)		25 (0.143)		15 (0.086)		25 (0.143)		
Repeatability	µm (in ³)	+/-10 (0.4)		+/-10 (0.4)		+/-10 (0.4)		+/-10 (0.4)		
Ambient Temperature	°C	5 to 30		5 to 30		5 to 30		5 to 30		

Belt Driven Modules



Thrust Load capacity of BLMA (F_x)

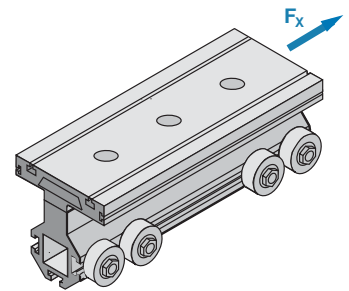
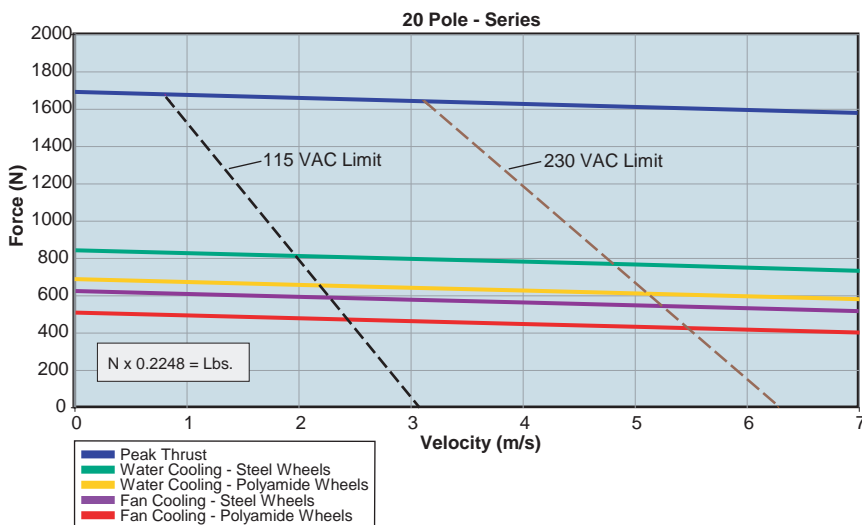
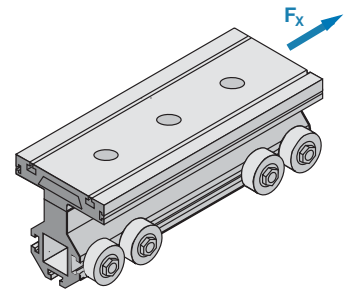
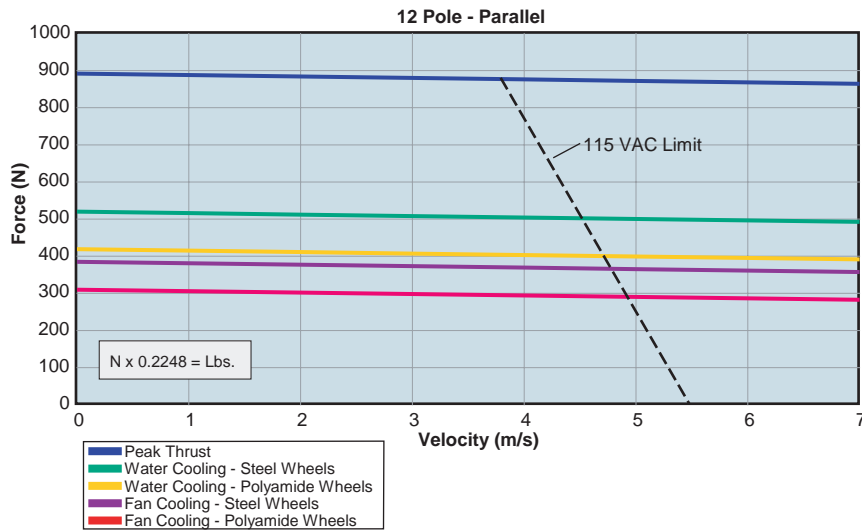
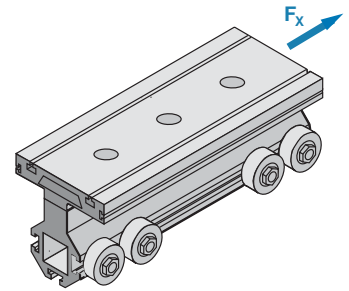
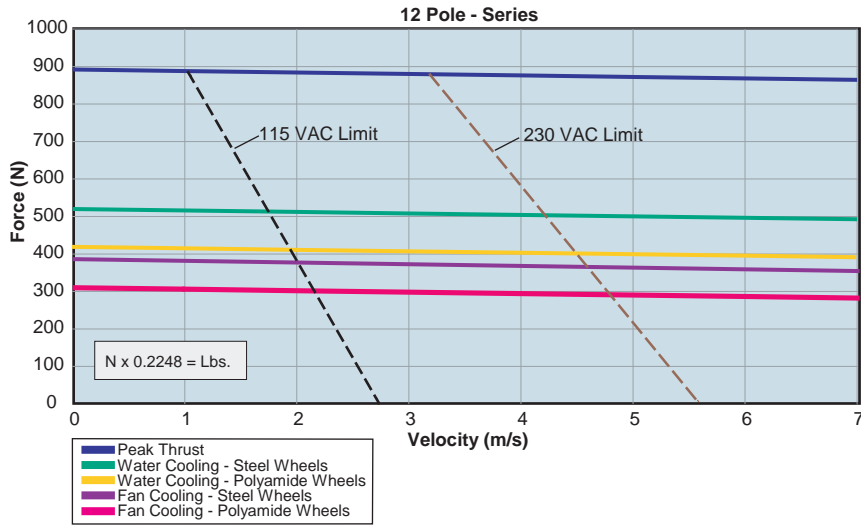

Thrust Load capacity of BLMA (F_x)

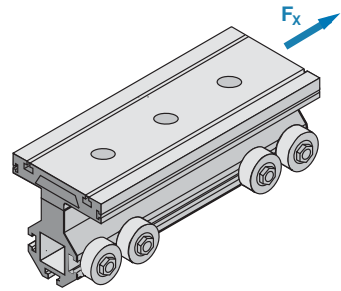
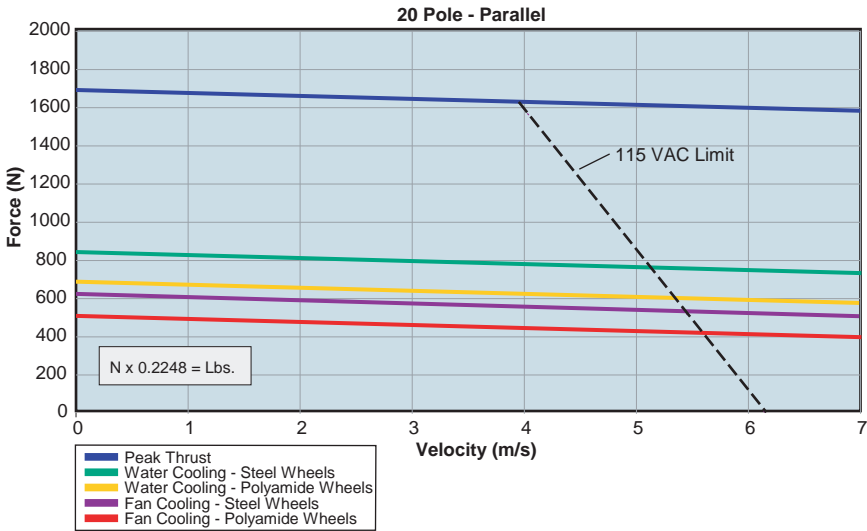

Load-bearing capacity of BLMA (F_y and F_z)

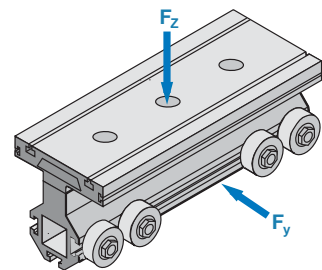
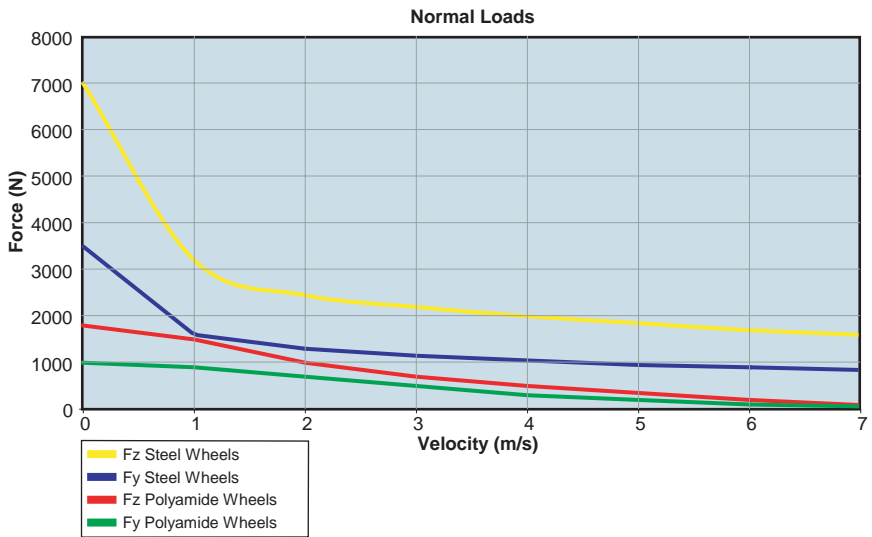

Maximum permissible Moment Load - BLMA (M_x , M_y and M_z)

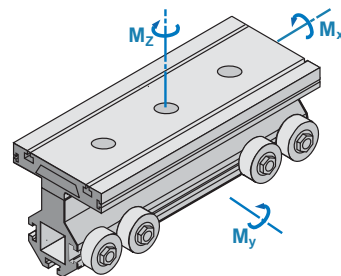
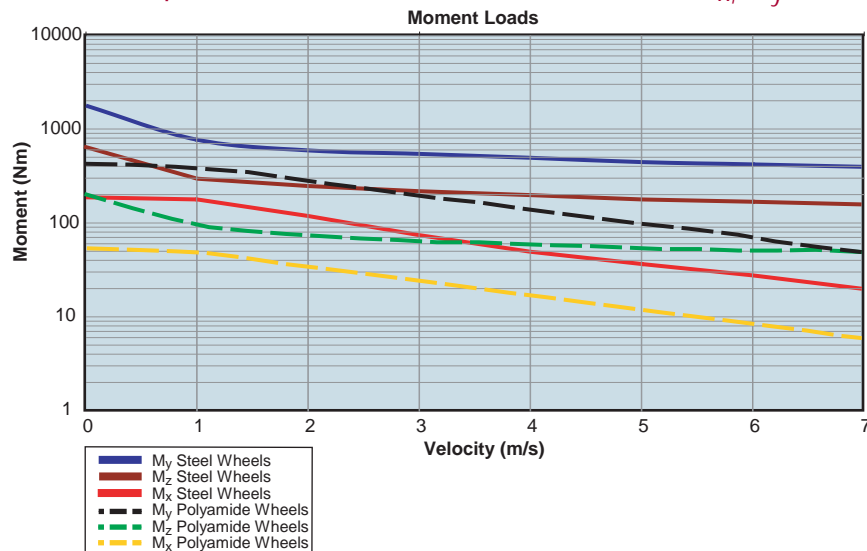

BLMA Dimensions (mm)

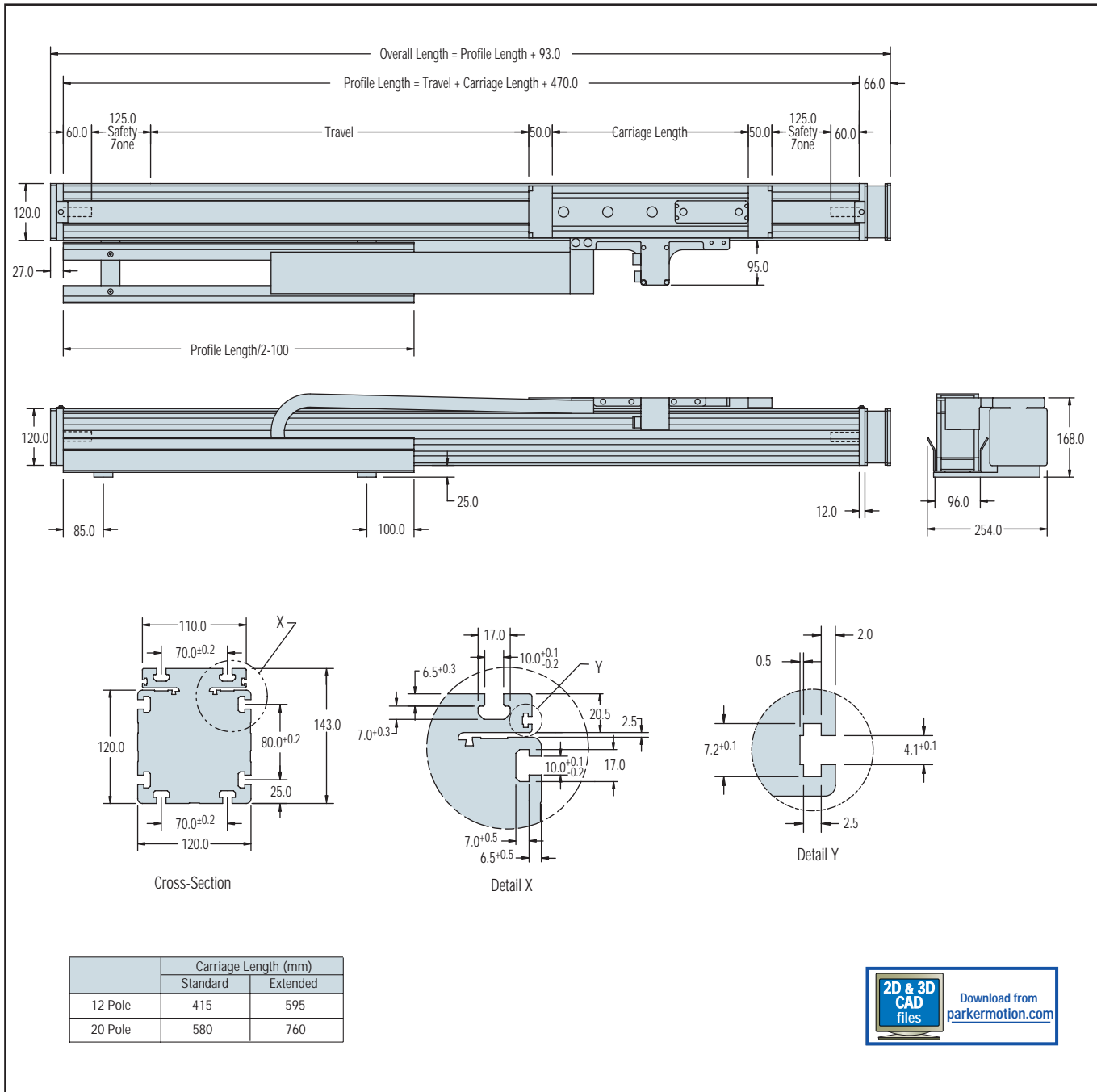

BLMA Drive Option

Compax3



Compact, Intelligent and Powerful Industrial Servo Drives & Drive/Controllers

With its high-performance and modular design, the Compax3 family of industrial servo drives and drive/controllers offers a new level of servo performance and flexibility. The modular capacity of the Compax3 family allows options such as intelligent motion controllers, fieldbus interfaces and industry standard motor feedback. In addition, numerous expansion options can be added to the standard product in order to optimize the capabilities required for today's demanding servo applications.

Refer to the Motor Data Table on page D36 for specific BLMA power level and Part Number information. Also, see Parker "Motion Control Systems" catalog for detailed information and specifications regarding the Compax 3.

Features

- Available in both 120/240 VAC and 480 VAC input versions
- Current output from 2.5 A (rms) continuous to 30 A (rms) continuous
- Resolver, encoder or high-resolution SinCos® Absolute rotary encoder feedback (single- or multi-turn)
- Internal regeneration circuitry; external resistor connections for additional power dissipation
- Easy-to-use wizards-based configuration and programming via C3 ServoManager™ software package
- Full diagnostic, tuning and 4-channel oscilloscope tools provided in the standard C3 ServoManager™ software
- CE (EMC & LVD), UL, cUL approval



T10 Features

- Base servo drive
- ±10 V analog
- Step and direction
- Torque/velocity control
- Position control
- Encoder tracking

T11 Features

- Base indexer drive
- Up to 31 stored profiles
- Profile select via digital inputs
- Multi-profile sequences
- Profibus
- CANopen

T30 Features

- Full-featured programmable drive/controller
- IEC61131-3 programming flexibility
- PLCopen, Parker motion function blocks
- Complex motion
- Profibus
- CANopen

T40 Features

- T30 programming capability
- Electronic cam control
- Electronic gearing
- Position capture
- Profibus
- CANopen
- HEDA

Belt Driven Modules

BLMA Series How to Order

Order Example:

BLMA 120 D2 D0 W1 B1 T2000 C1 CM05

Model Series BLMA

Type 120

Drive System 1

Idler Unit D0

12 Pole Linear Motor Drive D2

20 Pole Linear Motor Drive D3

Drive System 2

No Second Carriage D0

12 Pole Linear Motor Drive D2

20 Pole Linear Motor Drive D3

Motor Winding

Series Winding W1

Parallel Winding W2

Bearing Option

Polyamide Rollers B1

Steel Rollers B2

Travel

Specify Desired Travel (mm) Tnnnn

Carriage

Standard Length Carriage with Load Plate C1

Extended Length Carriage with Load Plate C2

Cable Management

No Cables CM01

2.5 m OEM Cable Set - Compax3 CM02

7.5 m OEM Cable Set - Compax3 CM03

15 m OEM Cable Set - Compax3 CM04

Cable Carrier w/2.5 m - Compax3 CM05

Cable Carrier w/7.5 m - Compax3 CM06

Cable Carrier w/15 m - Compax3 CM07

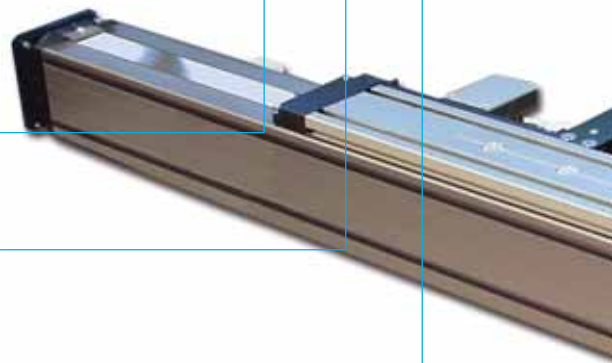

E2 L2 H3 R1 CL3

Cooling

- CL1 No Fan
- CL2 Single Fan
- CL3 Dual Fan
- CL4 Water Cooling

Environmental Option

- R1 Standard Preparation with Strip Seal Cover
- R2 Standard preparation with No Strip Seal Cover

Home Sensor

- H1 None
- H2 One NPN Prox Switch, 10-30 VDC
- H3 One PNP Prox Switch, 10-30 VDC
- H4 Two NPN Prox Switches, 10-30 VDC
- H5 Two PNP Prox Switches, 10-30 VDC

Limit Sensors

- L1 None
- L2 Two NPN Prox Switches, 10-30 VDC
- L3 Two PNP Prox Switches, 10-30 VDC

Encoder

- E1 None
- E2 Sine Cosine Feedback for Compax3

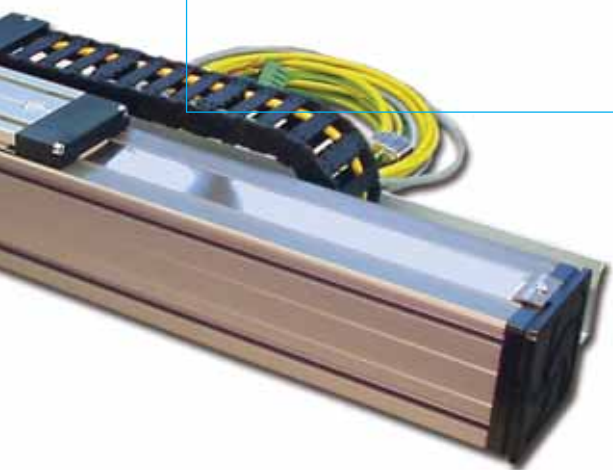

Belt Driven Modules

HLE-RB Series

Features

- ❑ Standard travel up to 7.9 meters*
- ❑ Load Capacities up to 600 kg
- ❑ ± 0.2 mm positional repeatability
- ❑ Timing belt and pulley drive mechanism for fast, accurate positioning
- ❑ Roller wheel bearings for smooth high speed linear motion
- ❑ IP30 strip seal

*Longer travels available with splice kits.



Housing:

Lightweight and self-supporting aluminum profiles are offered in three sizes:

HLE60: 60 x 60 mm

HLE100: 100 x 100 mm

HLE150: 150 x 150 mm

T-slots are provided for mounting the linear unit itself, applying additional components and accessories, or combining multiple HLEs. T-slots with plastic covers provide a simple cable conduit.

Load Attachment Plate

Load attachment plates are available for every type of carriage. With integral T-slots or tapped with holes in a standard mounting pattern, they allow easy mounting of your load to the carriage of the HLE. Multiple HLEs can easily be mounted together by using standard clamping profiles. Tripping plates are mounted to the side of the load attachment plate to activate home or end of travel switches mounted to the side of the HLE. For special applications, the load plates can be designed to customer specified requirements.

Drive Station

Rigid cast housing with standard flanges for a variety of gearboxes. The drive stations are designed to accept planetary and worm gear reducers or provide different shaft outputs for driving the HLE.

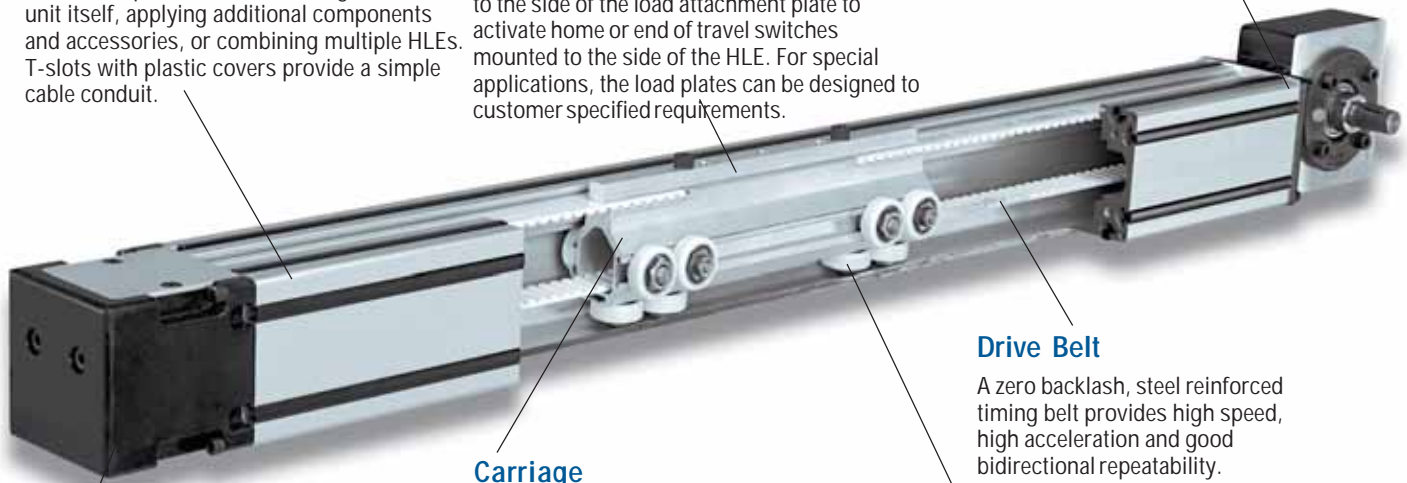

Tensioning Station

"Easy access" tensioning bolts allow external adjustment of belt tension.

Carriage

Roller bearing wheels are installed on three sides of the carriage to provide smooth linear motion and support. The wheels are positioned to evenly distribute the load across the length of the carriage. Eccentric bearing wheel bushings are adjusted to eliminate play on all sides of the carriage. Due to a low coefficient of friction, the carriage design provides a high mechanical efficiency and long service life. The carriages are available in standard and extended lengths. Special carriage lengths and linear units with multiple carriages are available for custom applications.

Drive Belt

A zero backlash, steel reinforced timing belt provides high speed, high acceleration and good bidirectional repeatability.

Roller Bearing

Each wheel consists of a lubricated and sealed radial ball bearing to reduce friction and maintenance. The bearing is enclosed within a tough polyamide tread to reduce noise and provide long service life.

IP30 Strip Seal

Magnetically attached stainless steel seal strip (not shown in this illustration) provides environmental protection to interior components.

HLE-RB Series

The HLE-RB linear modules are ideal as single axis products or as components for high speed multi-axis gantries. With thousands of units in operation worldwide the HLEs are proven performers offering long life and trouble-free operation.

Construction: The HLE Linear Module consists of a lightweight carriage which can be precisely positioned within an extruded aluminum housing by a timing belt and pulley drive system. The housing, constructed from extruded

aluminum with a square cross sectional geometry, demonstrates excellent deflection characteristics.

The protective "anolite" coating provides durability as well as an attractive silver appearance. It includes T-slots along its entire length for flexible mounting. The drive mechanism is a zero backlash steel reinforced timing belt. The tension station, conveniently located at the end of the unit provides for quick and easy belt adjustment. The drive station is designed to accept

planetary gear reducers as well as a wide variety of servo and stepper motors. The bearing system for the RB models is comprised of three rows of roller wheels integral to the carriage which are guided by extruded tracks within the housing.

Proven Technology

Proven in numerous applications, the HLE-RB series offers the following advantages:

- Low running friction
- Low particle generation (clean room suitability to class 100)
- Low wear
- Low maintenance
- Quiet operation
- High efficiency
- Long service life
- High dynamic performance due to low-mass, play-free wheels
- Minimal preventative maintenance required
- T-slots integrated on all sides of the profile for mounting attachments or for use as a cable duct
- Timing belts can be replaced without removing load attachment plate
- Multiple configuration options due to T-slots available on both the profile and load plate

Typical Fields of Application

As part of advanced, cost-effective construction of machines and handling systems:

- **Materials handling:** palletizing, depalletizing, feeding, part removal
- **Cleanroom technology:** wafer transport, wafer coating
- **Warehouse technology:** parts picking, storage and retrieval
- **Machine tool automation:** workpiece loading and unloading, tool changing
- **Construction:** formwork, placing reinforcing steel bars in concrete
- **Process engineering:** painting, coating, bonding
- **Testing technology:** guiding ultrasonic sensors, laboratory equipment
- **Textile machinery:** crosscutting, slitting and stacking, quilting, seam stitching

Optional Features

- Direct mounting for planetary gear reducers
- Adjustable "end of travel" limit switches and "home" position sensor
- Clean room preparation option
- Cable carrier systems
- Performance matched Parker servo systems
- Structural components for vertical and multi-axis mounting
- Toe clamps and hardware for fast and easy mounting
- External bumpers
- Link shafts and support bearings for dual axis units
- Splice plates for extending travels beyond length available in a single profile

The T-slots of the load attachment plate and the HLE profile are suitable for T-nuts and T-bolts.

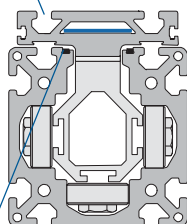

Magnetic strips recessed in the profile ensure that the strip seal is fully sealed with the profile.

Plastic caps protect the interior from dust.

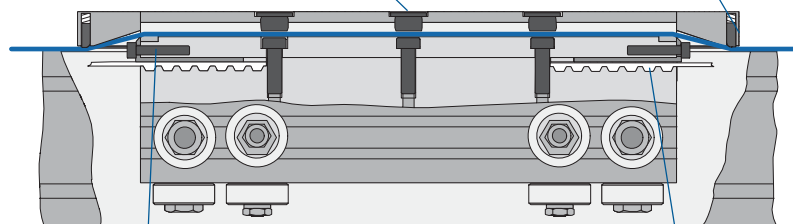

Polymer inlays serve as a bearing surface for the strip seal.

A spring-loaded felt insert cleans the strip seal.

The timing belt is attached to the carriage with a serrated clamp mechanism which assures a strong connection and makes belt replacement easy without the need to remove payload.

HLE-RB Characteristics

Characteristic	Units	HLE60-RB	HLE100-RB	HLE150-RB
Unit Weight (Basic unit without stroke)				
Standard Carriage, NL	kg (lb)	2.28 (5.03)	12.70 (28.00)	31.20 (68.80)
Extended Carriage, VL	kg (lb)	3.98 (8.77)	15.80 (34.84)	38.50 (84.89)
Carriage Weight				
Standard Carriage, NL	kg (lb)	0.8 (1.76)	2.80 (6.17)	7.30 (16.10)
Extended Carriage, VL	kg (lb)	1.3 (2.87)	4.40 (9.70)	11.50 (25.36)
Weight per travel of additional length	kg/m (lb/ft)	3.62 (2.43)	10.00 (6.72)	21.10 (14.18)
Moment of Inertia (related to the drive shaft)				
Standard Carriage, NL	kg-cm ² (lb-in ²)	3.07 (1.05)	24.60 (8.41)	123.30 (42.17)
Extended Carriage, VL	kg-cm ² (lb-in ²)	4.81 (1.64)	36.40 (12.45)	183.60 (62.79)
Travel and Speed				
Maximum Speed ⁽¹⁾	m/s (in/s)	5 (200)	5 (200)	5 (200)
Maximum Acceleration ⁽¹⁾	m/s ² (in/s ²)	10 (393)	10 (393)	10 (393)
Maximum Travel ² – standard carriage, NL	m (in)	3.0 (120)	6.2 (244)	7.9 (311)
Maximum Travel ² – extended carriage, VL	m (in)	2.8 (114)	6.0 (238)	7.7 (305)
Geometric Data				
Cross section, Square	mm (in)	57.1 (2.25)	100.0 (3.94)	150.0 (5.91)
Moment of Inertia I _x	cm ⁴ (in ⁴)	55.8 (1.34)	383.0 (9.20)	1940.0 (46.61)
Moment of Inertia I _y	cm ⁴ (in ⁴)	56.2 (1.35)	431.0 (10.35)	2147.0 (51.58)
Modulus of Elasticity	N/mm ² (lb/in ²)	0.72 x 10 ⁵ (0.1044 x 10 ⁶)	0.72 x 10 ⁵ (0.1044 x 10 ⁶)	0.72 x 10 ⁵ (0.1044 x 10 ⁶)
Pulley Data, Torques, Forces				
Travel Distance per Revolution	mm/rev (in/rev)	125 (4.92)	170 (6.69)	240 (9.45)
Pulley Diameter	mm (in)	39.8 (1.57)	54.1 (2.13)	76.4 (3.01)
Maximum Drive Torque ⁽³⁾	Nm (lb-in)	8.87 (78.5)	40.0 (354.0)	108.0 (955.9)
Maximum Belt Traction (effective load) ⁽³⁾	N (lb)	Refer to charts on following page		
Repeatability ⁽⁴⁾	mm (in)	±0.2 (±0.008)	±0.2 (±0.008)	±0.2 (±0.008)

For the following deviations from the above standards, please contact Parker engineering:

- (1) Greater speeds and accelerations may be achieved.
- (2) Splicing possible for longer travel distances. This may cause reductions in effective load, drive torque, speed, acceleration, and repeatability. Consult factory for strip seal availability on spliced units.
- (3) Increased timing belt tension required.
- (4) Nominal value - component dependent. For improved repeatability consult factory.

Relative Size Comparison

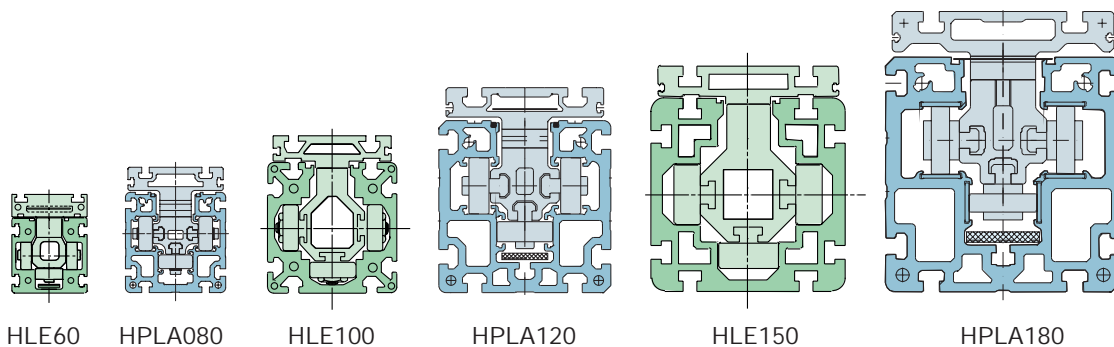

HLE-RB Series – Forces and Moment Loads

The forces and moments that the carriage is capable of transferring are speed-dependent.

The curves shown in the graphs apply to a standard carriage (S). With the extended carriage (E), all the values apart from F_x (load-bearing capacity of timing belt) can be doubled if the load is applied equally to both halves of the carriage or distributed uniformly along its entire length.

The curves show the maximum load-bearing capacity of a carriage in one direction of force or torque. If several loads are applied in different directions, the values given by the curves must be derated, i.e. the load or speed should be reduced if necessary.

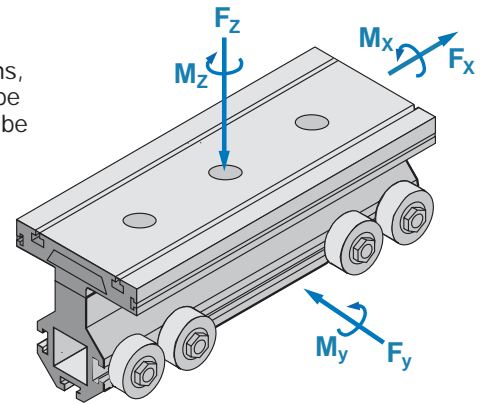

The software package "DimAxes" is available for determination of precise carriage loading. Visit www.parkermotion.com to request a Gantry Robot CD.

Load-bearing capacity timing belt (F_x)

HLE60-RB Drive Option	Transferrable Thrust Force (N)	
	Nominal Belt Tension (81,000 km life)	Maximum Belt Tension (46,000 km life)
Supported Pulley (SP1 - SP12)	500	665

HLE100-RB Drive Option	Transferrable Thrust Force (N)	
	Nominal Belt Tension (81,000 km life)	Maximum Belt Tension (46,000 km life)
GTN115	925	1115
GTN090, PEN115	675	900
PEN090	500	665

HLE150-RB Drive Option	Transferrable Thrust Force (N)	
	Nominal Belt Tension (85,000 km life)	Maximum Belt Tension (37,000 km life)
GTN142	1700	2235
GTN115	1515	2015
PEN115	675	900

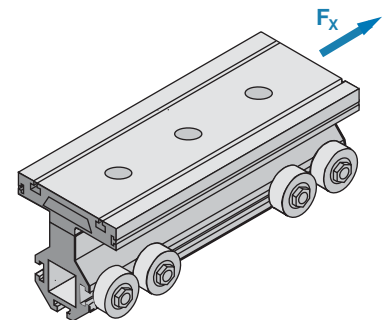

Belt Driven Modules

HLE-RB Series – Force and Moment Loads

Load-bearing capacity

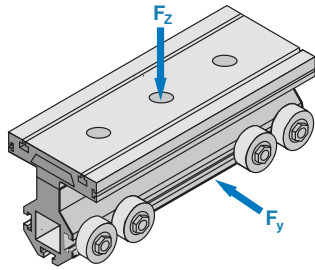

Maximum permissible Moment Load

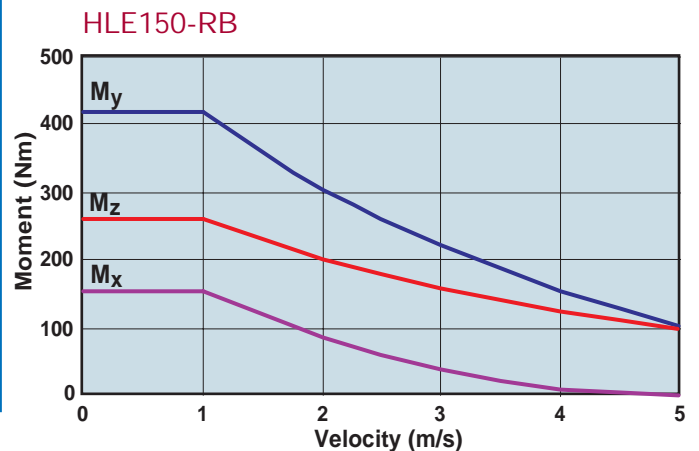
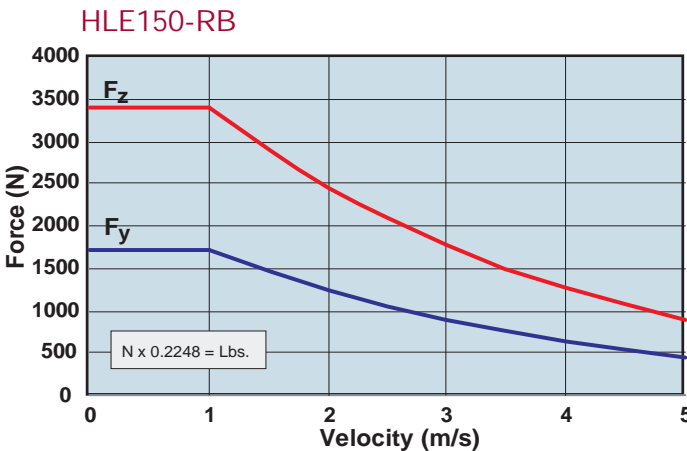
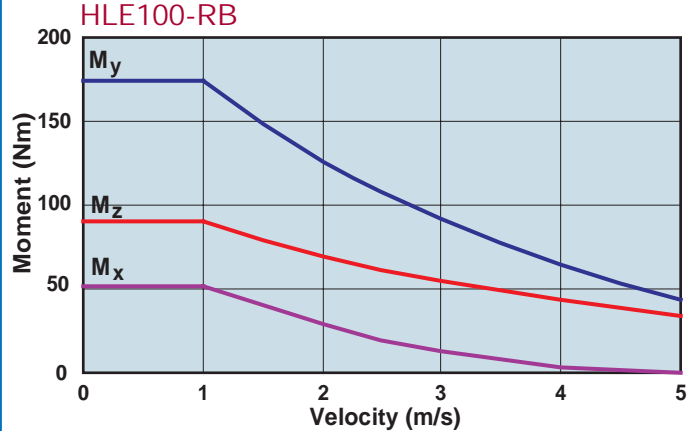
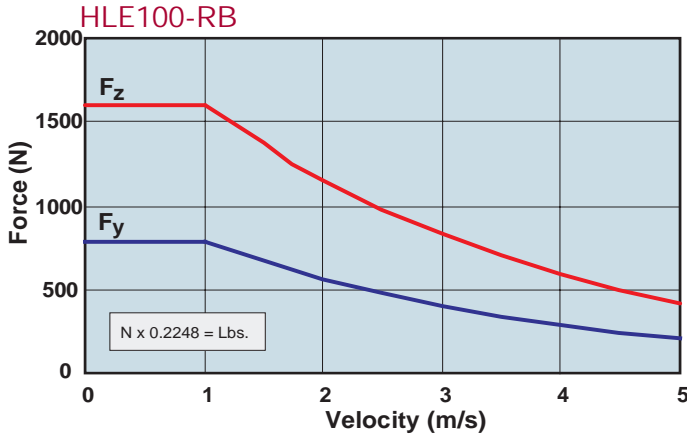
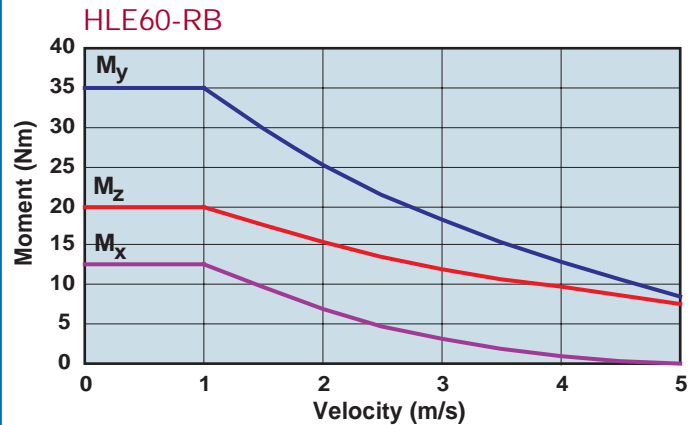
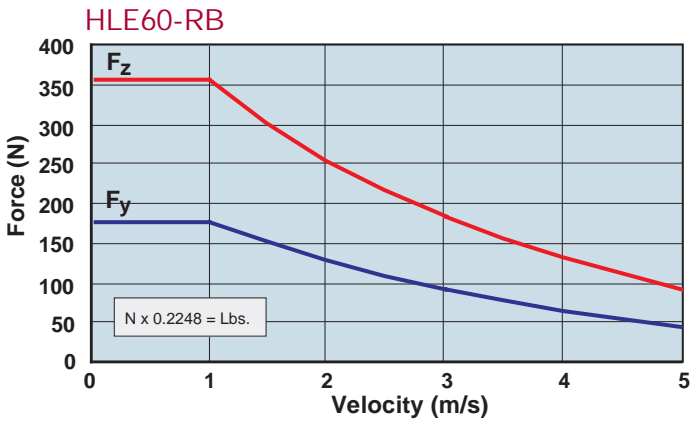
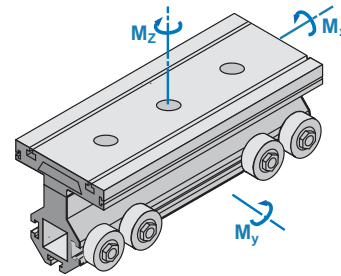

HLE-RB Deflection Characteristics

The HLE deflection curves can be used for determining the deflection based on the profile length and the application load weight. Applications requiring high acceleration forces can place a severe strain on the system stability. In these cases, a solid substructure may be required with the HLE product being supported at frequent intervals.

These deflection curves illustrate the deflection f , based on the HLE profile being simply supported at both ends. The graphs take into consideration the self deflection due to the weight of the profile, along with the load to be transported. The maximum deflection cannot be exceeded. If the maximum deflec-

tion is exceeded based on your application parameters, then additional supports are required. Alternatively, the next larger profile size may be considered. For deflection formulas and calculations, please refer to the Technical Information Library found on our web site: www.parkermotion.com

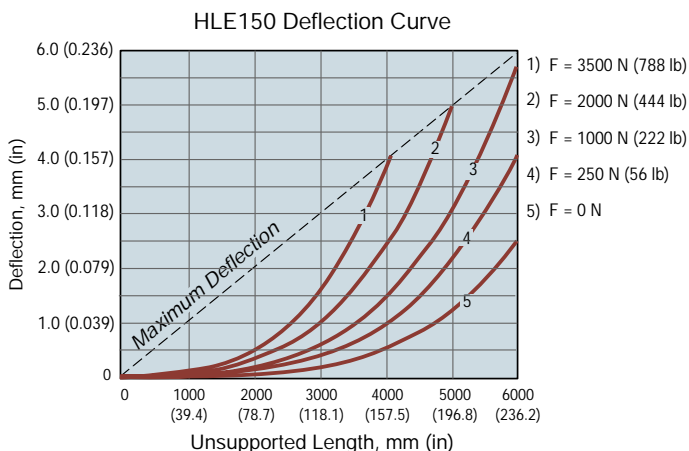
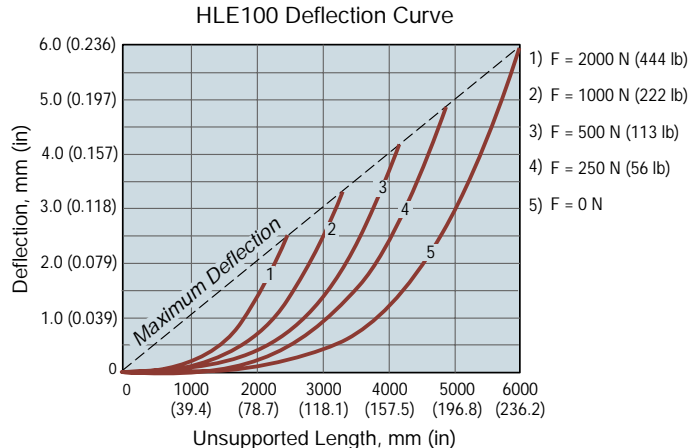
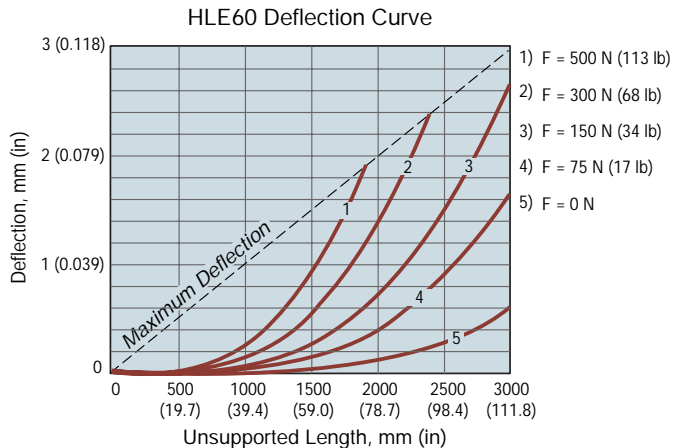
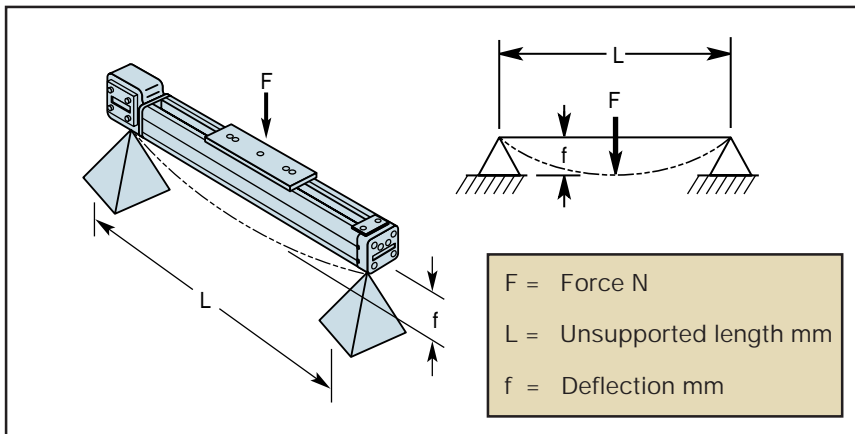

Dual Unit Axis Considerations

When two parallel linear modules are required to form a single axis, the span or distance between each unit determines which type of shaft connection is required. In some cases, a link shaft support bearing might also be required.

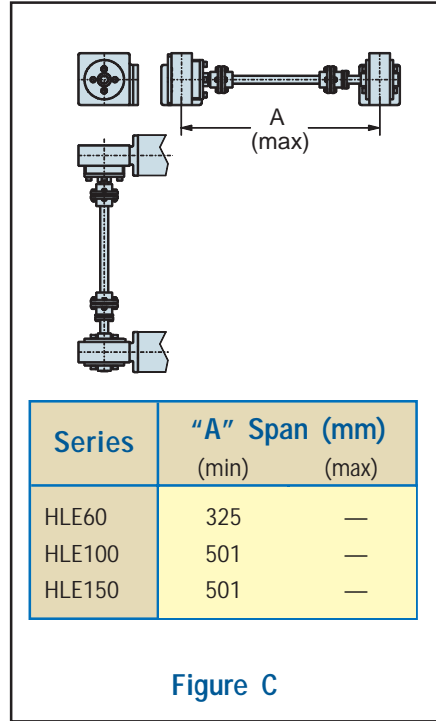
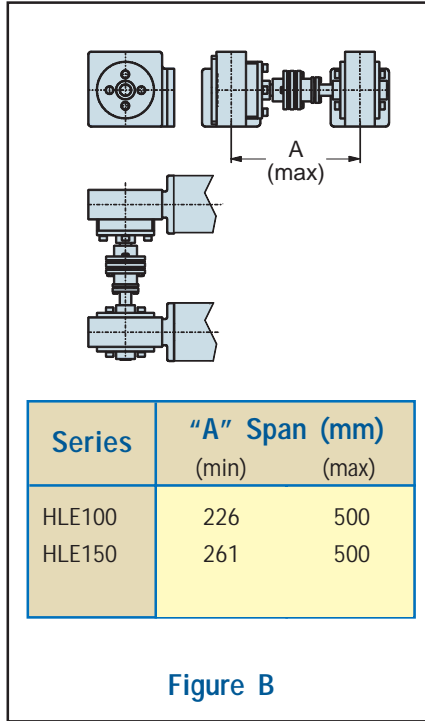
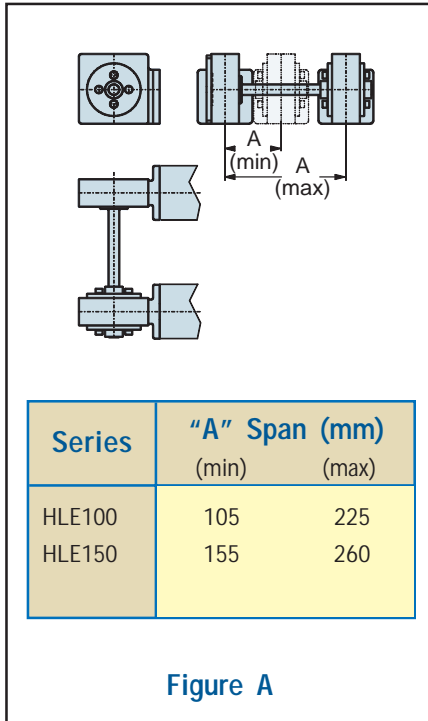

The link shaft bearing is used to support the linking shaft of an HLE dual axis when there is a large center to center distance. This bearing must be used if the critical speed is exceeded with the dual-axis link shaft.

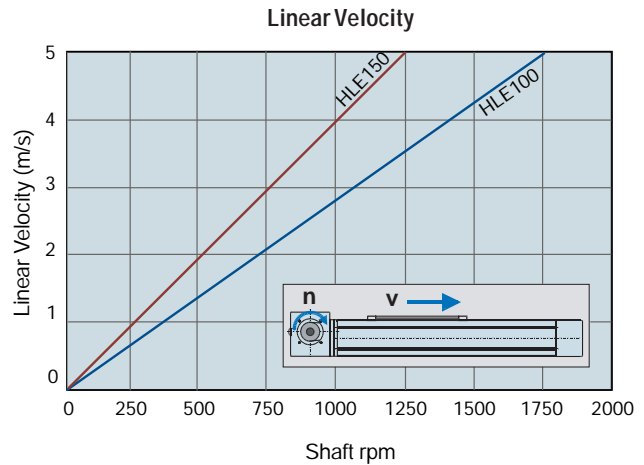
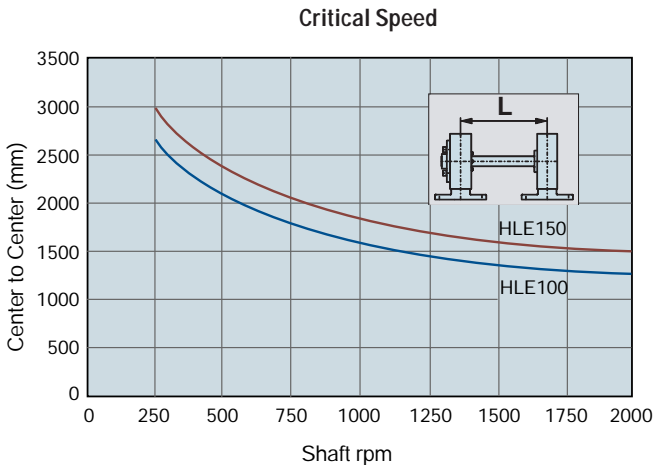

HLE60-RB Dimensions (mm)

Drive Unit

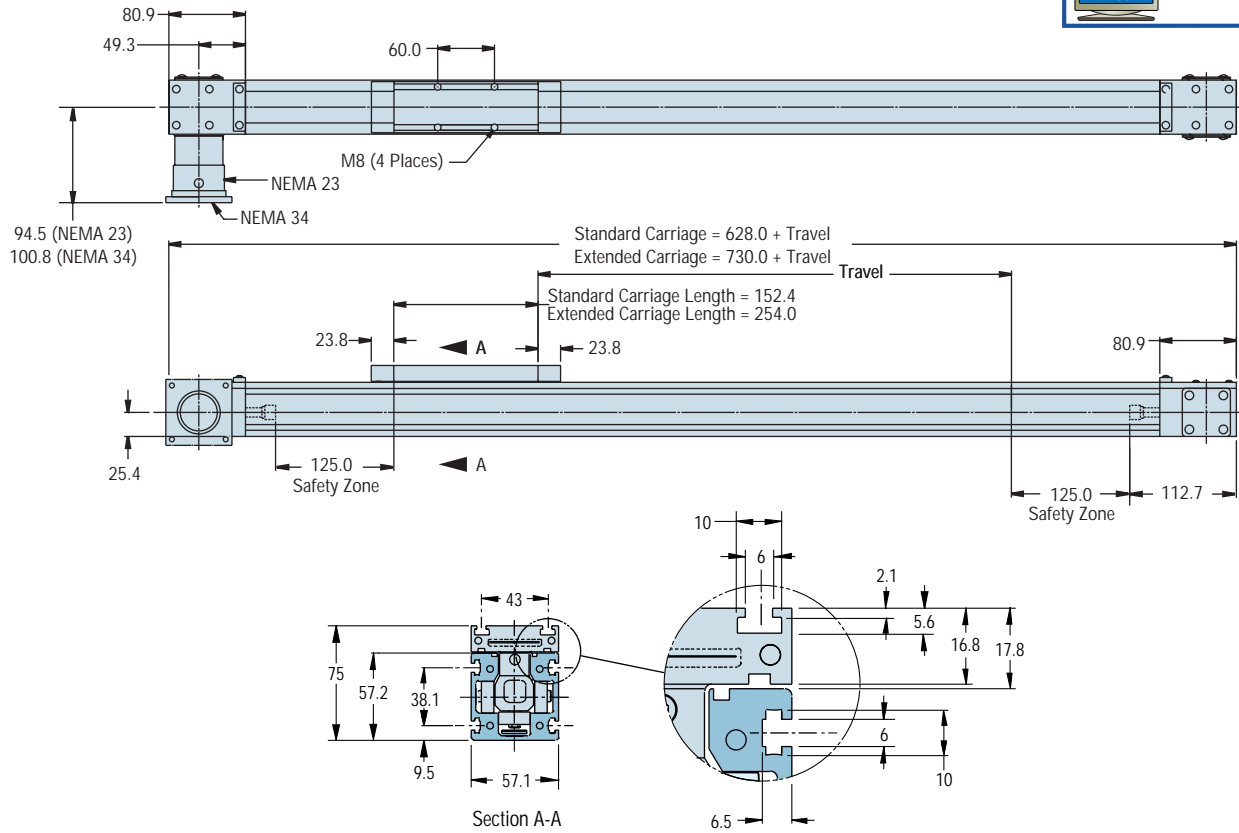

Drive Shaft Option

WRO Shaft on Right
WLO Shaft on Left
WBO Shaft on Both Sides

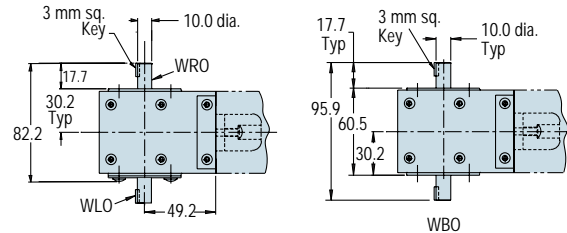

Idler Unit (top view)

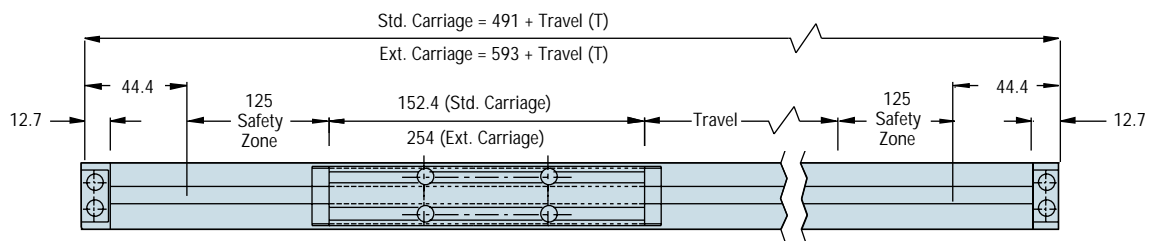

HLE100-RB Dimensions (mm)



Drive Unit

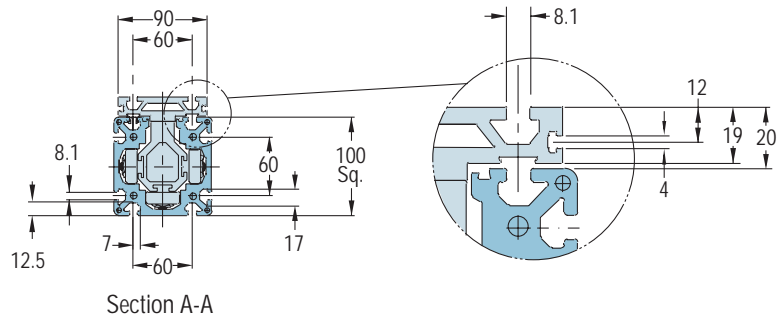
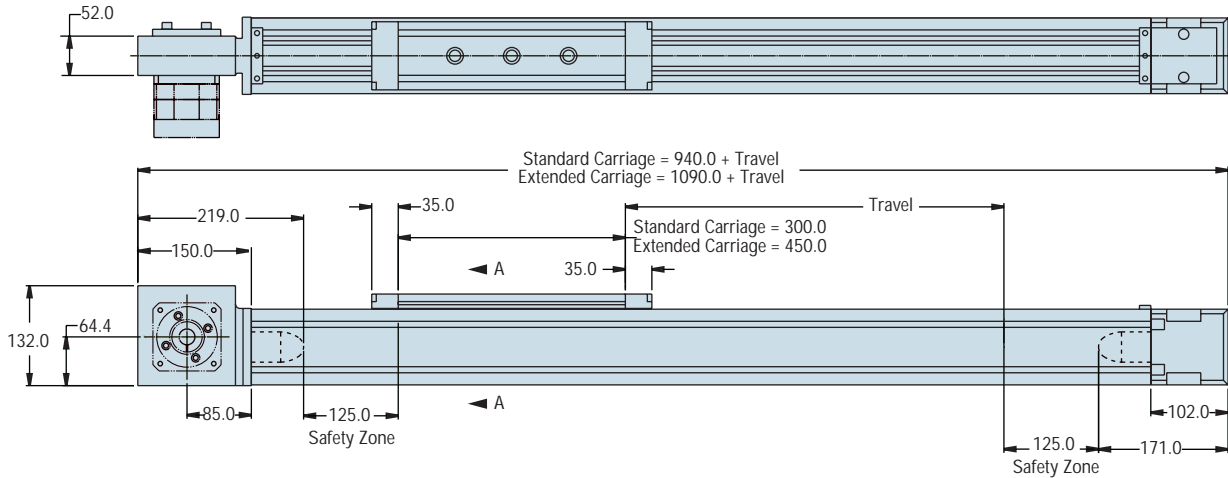

Drive Shaft Option

- WRO Shaft on Right
- WLO Shaft on Left
- WBO Shaft on Both Sides

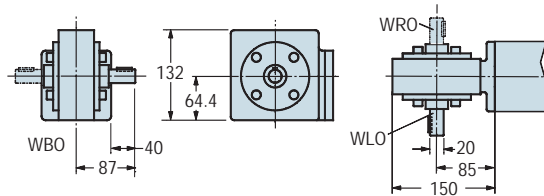

Idler Unit (top view)

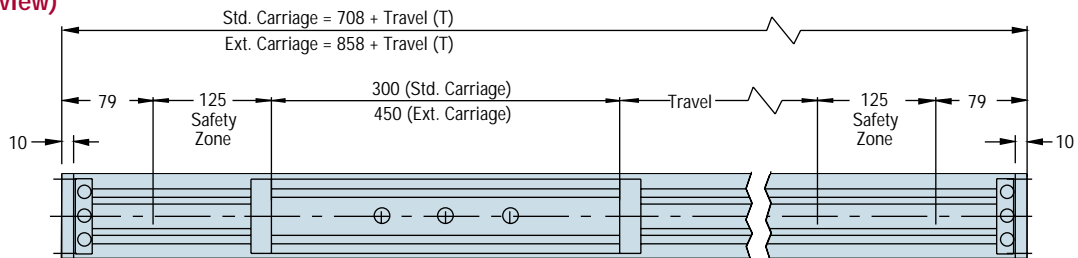

HLE150-RB Dimensions (mm)



Drive Unit

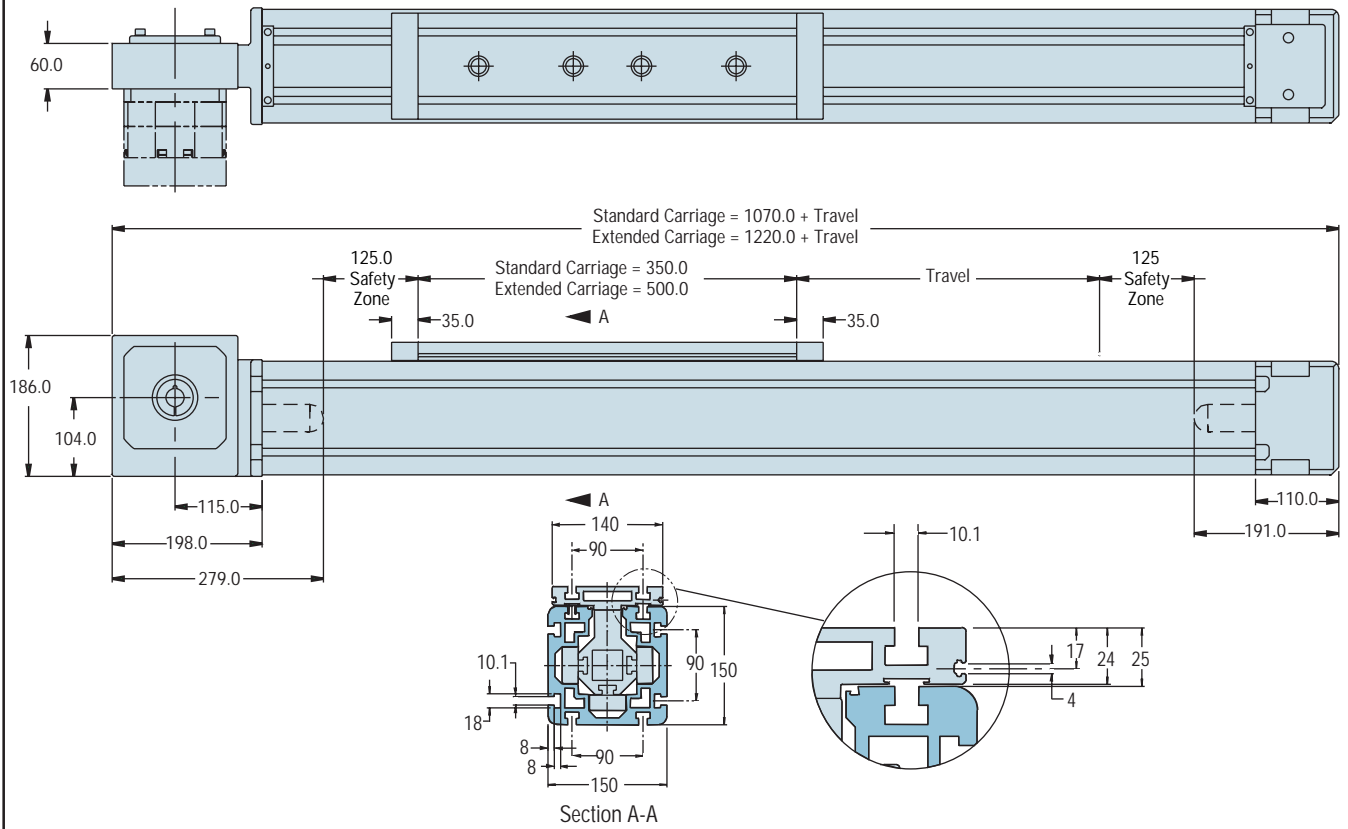

Drive Shaft Option

- WRO Shaft on Right
- WLO Shaft on Left
- WBO Shaft on Both Sides

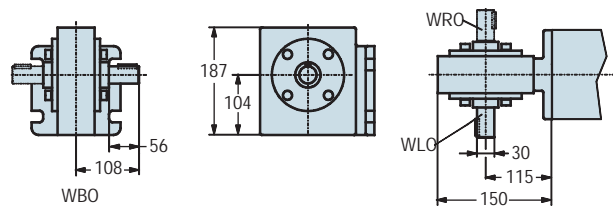

Idler Unit (top view)

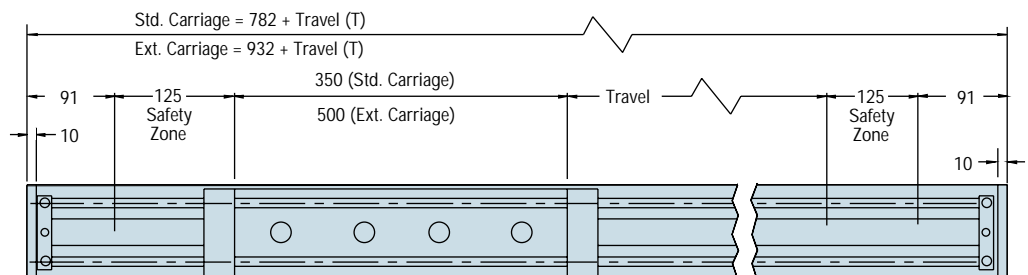

Belt Driven Modules



HLE60-RB How to Order

Order Example

HLE060 RB NL E 1000 DA0000 MBL SP5

Model Series HLE060

Bearing Type

RB RB

Carriage Type

Standard Carriage NL

Extended Carriage VL

Unit Type

Idler M

Timing Belt Drive, Nominal Thrust, Maximum Life E

Timing Belt Drive, Maximum Thrust, Nominal Life F

Travel Length

nnnn (nnnn=mm) nnnn

Drive Shaft Option - Center to Center

DA0000: No Drive Shaft - Single Axis or Idler Unit DA0000

DAnnnn (nnnn=mm) DAnnnn

Shaft Configuration Options

No Shaft, Idler Unit WOO

Shaft Left WLO

Shaft Right WRO

Double Shaft WBO

Motor Block Left MBL

Motor Block Right MBR

Motor Block Left, Shaft Right MLW

Motor Block Right, Shaft Left MRW

Double Axis, Motor Block Left DML

Double Axis, Motor Block Right DMR

WOO

WLO WRO WBO

MBL MBR

MLW MRW

DML

DMR



Drive Station Interface

Idler, Requires WOO Option SP0

No Motor Block, Requires WRO, WLO, or WBO SP1

Motor Block - NEMA 23 with .375 in. coupling SP2

Motor Block - NEMA 23 with .250 in. coupling SP3

Motor Block - NEMA 34 with .375 in. coupling SP4

Motor Block - NEMA 34 with .500 in. coupling SP5

Motor Block - NEMA 23 without coupling SP8

Motor Block - NEMA 34 without coupling SP9

Motor Block - PTN/PTR-060 with 14 mm coupling SP10

Motor Block - NO70 Motor with 11 mm coupling SP11

Motor Block - GTN/GTR-070 with 16 mm coupling SP12

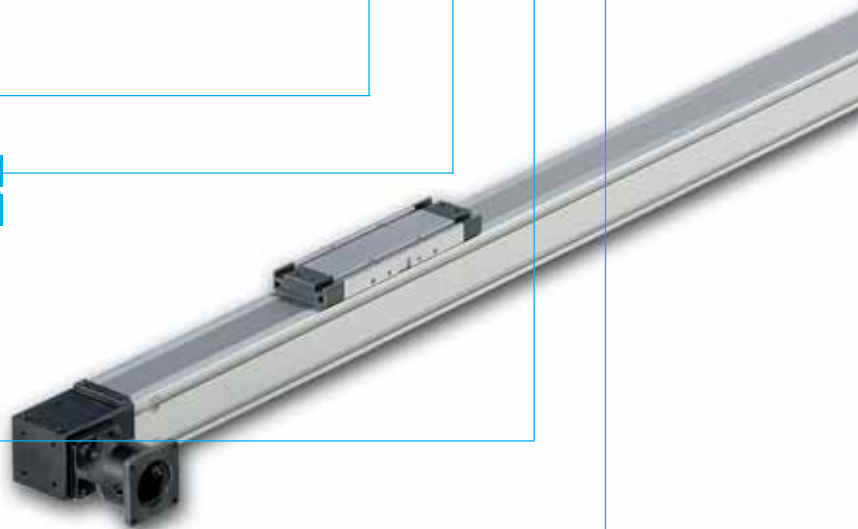

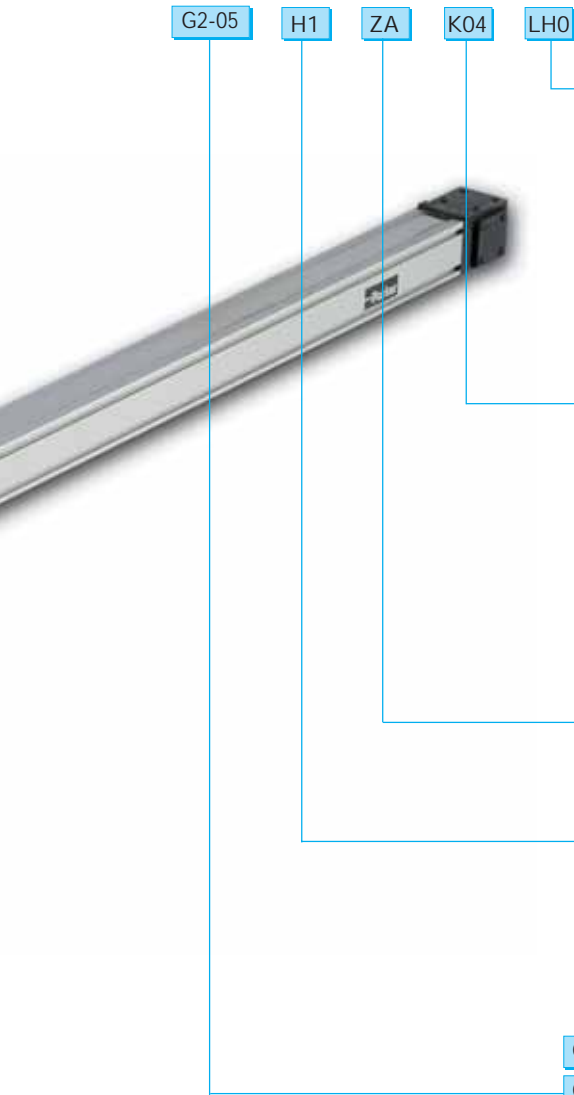

Limit/Home Switch Option

- LH0 No Limit Switch Assembly
- LH3 Three NPN Prox Switches, 10-30 VDC
- LH4 Three PNP Prox Switches, 10-30 VDC

Motor Kit Option

- K00 No motor kit
- K01 ES2*, OS2, S57-*, SM230*, SE230* to PT-060
- K02 B23* to PT-060
- K03 J034*, N034*, BE34*, TS3* to PT060
- K04 RS3*, OEM83*, ES3*, ZETA83-* to PT060
- K05 J070*, N070* to PT070
- K06 J070*, N070* to GT070
- K07 SM230, SE230, ES2*, OS2, S57-* to GT-070
- K08 SM/SE 231, 232, 233, TO GT-070
- K09 J09*, N09* to GT-070

Strip Seal Option

- ZA Unit with Strip Seal (IP30)
- ZB Unit without Strip Seal

Mounting Orientation

- H1 Carriage Up
- H2 Carriage Down
- H3 Carriage on Side, Drive Station Up
- H4 Carriage on Side, Drive Station Down

Gearbox Option

- G0-00 No Gearbox
- G2-nn PTN060**
- G3-nn PTR060**
- G4-nn GTN070*
- G5-nn GTR070*

* Single stage ratios: 3,5,8,10; Dual stage ratios: 12,15,16,20,25
** Single stage ratios: 3,4,5,8; Dual stage ratios: 9,12,15,16,20,25

Belt Driven Modules

HLE100-RB How to Order

Order Example: **HLE100** **RB** **NL** **E** **1000** **DA0000** **ARO** **SP7**

Model Series	HLE100
Bearing Type RB	RB
Carriage Type Standard Carriage	NL
Extended Carriage	VL
Unit Type Idler	M
Timing Belt Drive, Nominal Thrust, Maximum Life	E
Timing Belt Drive, Maximum Thrust, Nominal Life	F
Travel Length nnnn (nnnn=mm)	xxxx
Drive Shaft Option - Center to Center DA0000: No Drive Shaft - Single Axis or Idler Unit	DA0000
DAnnnn (nnnn=mm)	DAnnnn
Shaft Configuration Options No Shaft, Idler Unit	WOO
Shaft Left	WLO
Shaft Right	WRO
Double Shaft	WBO
Reducer Left	ALO
Reducer Right	ARO
Reducer Left, Shaft Right	ALW
Reducer Right, Shaft Left	ARW
Double Axis, Drive Left	DAL
Double Axis, Drive Right	DAR
Motor Block Left	MBL
Motor Block Right	MBR

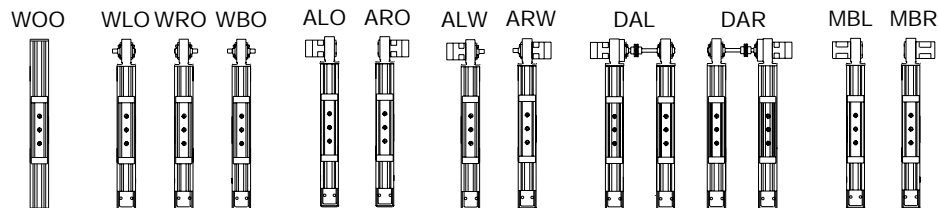
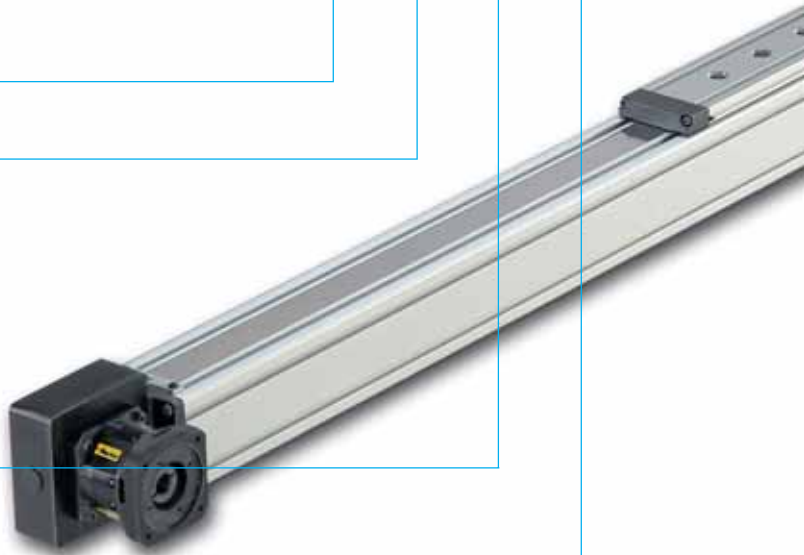

Drive Station Interface Idler or Shaft Option	SP0	Motor Block - NEMA 34 without coupling	SP5
Drive Housing for GTN, GTR-090	SP1	Motor Block - with coupling for JO923 direct drive	SP6
Drive Housing for GTN, GTR, PEN, and PER -115	SP2	Motor Block - NEMA 42 with .625 in. coupling	SP7
Motor Block - NEMA 34 with .500 in. coupling	SP3	Motor Block - NEMA 42 without coupling	SP8
Motor Block - NEMA 34 with .375 in. coupling	SP4	Drive Housing for PEN, PER-090	SP9



Limit/Home Switch Option

- LH0 No Limit Switch Assembly
- LH1 Three Mechanical Switches, 1 NO and 1 NC contact per switch
- LH2 Two Mechanical Switches, 1 NPN Prox Switch
- LH3 Three NPN Prox Switches, 10-30 VDC
- LH4 Three PNP Prox Switches, 10-30 VDC

Motor Kit Option

- K00 No motor kit
- K01 J034*, N034*, BE34*, TS3* to GT-090,PE-090
- K02 J070*, N070* to GT-090,PE-090
- K03 J090*, N090* to GT-090,PE-090
- K04 M105* to GT-090,PE-090
- K05 ES3*, OEM83-*, ZETA83-*, S83-*, RS3* to GT-090,PE-090
- K06 J034*, N034*, BE34*, TS3* to GT-115,PE-115
- K07 J090*, N090* to GT-115,PE-115
- K08 ES3*, OEM83-*, ZETA83-*, S83-*, RS3* to GT-115,PE-115
- K09 S106-178, S106-250 to GT-115,PE-115
- K10 M145 to GT-115,PE-115

Strip Seal Option

- ZA Unit with Strip Seal (IP30)
- ZB Unit without Strip Seal

Mounting Orientation

- H1 Carriage Up
- H2 Carriage Down
- H3 Carriage on Side, Drive Station Up
- H4 Carriage on Side, Drive Station Down

Gearbox Option

- G0-00 No Gearbox
- G2-nn PEN090**
- G3-nn PER090**
- G4-nn PEN115**
- G5-nn PER115**
- G6-nn GTN090*
- G7-nn GTR090*
- G8-nn GTN115*
- G9-nn GTR115*

* Single stage ratios: 3,5,8,10; Dual stage ratios: 12,15,16,20,25
 ** Single stage ratios: 3,4,5,8; Dual stage ratios: 9,12,15,16,20,25

Belt Driven Modules

HLE150-RB How to Order

Order Example

HLE150 RB NL E 1000 DA0000 ARO SP1

Model Series	HLE150
Bearing Type RB	RB
Carriage Type Standard Carriage	NL
Extended Carriage	VL
Unit Type Idler	M
Timing Belt Drive, Nominal Thrust, Maximum Life	E
Timing Belt Drive, Maximum Thrust, Nominal Life	F
Travel Length nnnn (nnnn=mm)	nnnn
Drive Shaft Option - Center to Center DA0000: No Drive Shaft - Single Axis or Idler Unit	DA0000
DAnnnn (nnnn=mm)	DAnnnn
Shaft Configuration Options No Shaft, Idler Unit	WOO
Shaft Left	WLO
Shaft Right	WRO
Double Shaft	WBO
Reducer Left	ALO
Reducer Right	ARO
Reducer Left, Shaft Right	ALW
Reducer Right, Shaft Left	ARW
Double Axis, Drive Left	DAL
Double Axis, Drive Right	DAR
Drive Station Interface Idler or Shaft Option	SP0
Drive Housing for GTN115	SP1
Drive Housing for GTN142	SP2
Drive Housing for PEN115	SP9

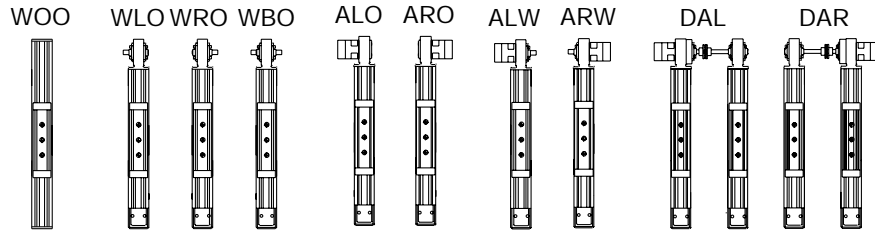
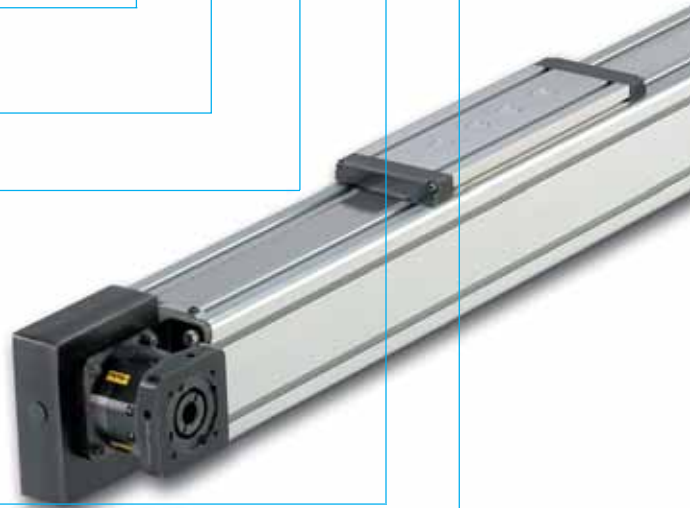



Limit/Home Switch Option

- LH0 No Limit Switch Assembly
- LH1 Three Mechanical Switches, 1 NO and 1 NC contact per switch
- LH2 Two Mechanical Switches, 1 NPN Prox Switch
- LH3 Three NPN Prox Switches, 10-30 VDC
- LH4 Three PNP Prox Switches, 10-30 VDC

Motor Kit Option

- K00 No motor kit
- K06 J034*, N034*, BE34*, TS3* to GT-115, PE-115
- K07 J090*, N090* to GT-115, PE-115
- K08 M105* to GT-115, PE-115
- K09 ES3*, OEM83*, ZETA83*, S83*, RS3* to GT-115, PE-115
- K10 RS42, RE42, S106-205 to GT-115, PE-115
- K11 S106-178, S106-250 to GT-115, PE-115
- K12 M145 to GT-115, PE-115
- K13 M145 to GT-142, PE-142

Steel Strip Option

- ZA Unit with Strip Seal (IP30)
- ZB Unit without Strip Seal

Mounting Orientation

- H1 Carriage Up
- H2 Carriage Down
- H3 Carriage on Side, Drive Station Up
- H4 Carriage on Side, Drive Station Down

Gearbox Option

- G0-00 No Gearbox
- G2-nn PEN115**
- G3-nn PER115**
- G4-nn GTN115*
- G5-nn GTR115*
- G6-nn GTN142*
- G7-nn GTR142*

* Single stage ratios: 3,5,8,10; Dual stage ratios: 12,15,16,20,25
 ** Single stage ratios: 3,4,5,8; Dual stage ratios: 9,12,15,16,20,25

Belt Driven Modules

HLE-SR Series

Features

- ❑ Heavy duty steel square rail bearing system for greater load capacity
- ❑ Standard travel to 6 meters*
- ❑ Load capacities up to 600 kg
- ❑ Velocity up to 3 meters/sec.
- ❑ ± 0.2 mm positional repeatability
- ❑ Timing belt and pulley drive mechanism
- ❑ IP30 strip seal

*Longer travels available with splice kits.



Housing

The HLE-SR housing, like the RB, is a light-weight, compact and self-supporting extruded aluminum section. It is available in two cross-sections: 60 x 60 mm (HLE60) and 100 x 100 mm (HLE100). T-slots along the length are utilized for clamping mechanical components, joining units, and attaching sensors or mechanical switches.

Carriage

A rigid carriage assembly is built upon two bearing housings which contain several rows of recirculating ball bearings designed to ride in grooves ground into a steel square rail linear raceway. Longer or custom carriages are also available.

Load Attachment Plate

Longitudinal grooves integrated on the top of this plate facilitate the assembly of attachments to the HLE-SR. Utilization of these grooves together with standard clamping profiles enables easy straight-forward construction of multi-axis systems.

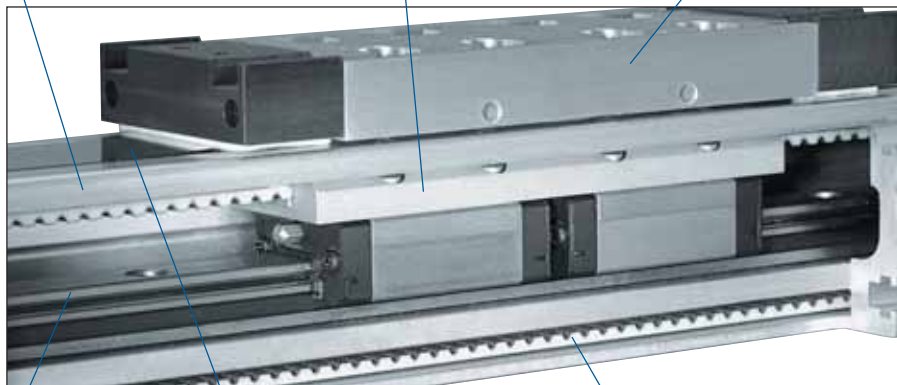

Bearing Raceway

A high strength steel alloy bearing rail features precision ground "gothic arch" raceways to provide precise translation and high strength support of the recirculating ball bearings.

Optional IP30 Strip Seal

Magnetically attached stainless steel seal strip (not shown in this illustration) provides environmental protection to interior components.

Drive Belt

A zero backlash, steel reinforced timing belt provides high speed, high acceleration and high bidirectional repeatability. A serrated clamp mechanism between belt and carriage guarantees a safe and strong connection.

HLE60-SR and HLE100-SR Series

HLE-SR Bearing System

The bearing system is the principal distinction between the RB type modules and the "SR" (Square Rail) type. The SR employs a square rail bearing system, which permits greater load carrying capability without increasing overall size. Square rail bearings are recirculating ball bearings designed to move heavy loads on a precise linear path. Linear guides, which house several rows of re-circulating ball bearings, ride on a high strength, steel square rail. The steel square rail cross section enables bearing ways to be

ground into the sides of the rail. These bearing ways are shaped in an arch which approximates the same radius as the ball bearing. This increases the contact surface between the ball and the rail, thereby increasing the load capacity of the linear bearing.

HLE-SR Drive Principle

The HLE-SR employs the same high performance belt and pulley drive mechanism as the HLE-RB. It features a zero backlash steel reinforced timing belt drive, which provides high speeds, high acceleration, and

good bidirectional repeatability. A belt tension station, conveniently located at the end of the unit provides for quick and easy belt adjustment. The drive station is designed to accept planetary gear reducers as well as a wide variety of servo and stepper motors.

Proven Technology

Proven in numerous applications, the HLE-SR series offers the following advantages:

- Low running friction
- Low wear
- Low maintenance
- Quiet operation
- High efficiency
- Long service life
- High dynamic performance due to high load capacity square rail systems
- Easily accessible lubrication points
- Minimal preventive maintenance required
- T-slots integrated on sides of the profile for mounting attachments or for use as a cable duct
- Timing belts can be replaced without removing load attachment plate
- Multiple configuration options due to T-slots available on both the profile and load plate

Typical Fields of Application

As part of advanced, cost-effective construction of machines and handling systems:

- **Materials handling:** palletizing, depalletizing, feeding, part removal
- **Clean room technology:** water transport, water coating
- **Warehouse technology:** parts picking, storage and retrieval
- **Machine tool automation:** workpiece loading and unloading, tool changing
- **Construction:** formwork, placing reinforcing steel bars in concrete
- **Process engineering:** painting, coating, bonding
- **Testing technology:** guiding ultrasonic sensors, laboratory equipment
- **Textile machinery building:** cross-cutting, slitting and stacking, quilting, seam stitching

Optional Features

- Direct mounting for planetary gear reducers
- Adjustable "end of travel" limit switches and "Home" position sensor
- Cable carrier systems
- Performance matched Parker servo systems
- Structural components for vertical and multi-axis mounting
- Toe clamps and hardware for fast/easy mounting
- External bumpers
- Link shafts and support bearing for dual unit axes
- Splice plates for extending travels beyond length available in a single profile



HLE-SR Series Specifications

Characteristic	Units	HLE60-SR	HLE100-SR
Unit Weight (basic unit without stroke)			
Standard Carriage, NL	kg (lb)	3.5 (7.7)	16.2 (35.7)
Extended Carriage, VL	kg (lb)	5.91 (13)	20.0 (44.1)
Carriage Weight			
Standard Carriage, NL	kg (lb)	0.82 (4.0)	2.2 (4.9)
Extended Carriage, VL	kg (lb)	1.12 (2.47)	3.8 (8.4)
Weight per meter of additional length	kg/m (lb/ft)	5.5 (3.7)	13.3 (8.9)
Moment of Inertia (related to the drive shaft)			
Standard Carriage, NL	kg-cm ² (lb-in ²)	3.52 (1.20)	34.8 (11.9)
Extended Carriage, VL	kg-cm ² (lb-in ²)	5.36 (1.83)	52.2 (17.9)
Travel and Speed			
Maximum Speed ⁽¹⁾	m/s (in/s)	3 (120)	3 (120)
Maximum Acceleration ⁽¹⁾	m/s ² (in/s ²)	10 (393)	10 (393)
Maximum Travel ⁽²⁾ , NL	m (in)	3.05 (120)	6.15 (242)
Maximum Travel ⁽²⁾ , VL	m (in)	2.8 (114)	6.0 (236)
Geometric Data			
Cross Section, Square	mm (in)	57.2 (2.25)	100 (3.94)
Moment of Inertia I _x	cm ⁴ (in ⁴)	48.3 (1.16)	377 (9.06)
Moment of Inertia I _y	cm ⁴ (in ⁴)	59.5 (1.43)	432 (10.38)
Moment of Elasticity	N/mm ² (lb/in ²)	0.72 x 10 ⁵ (0.1044 x 10 ⁹)	0.72 x 10 ⁵ (0.1044 x 10 ⁹)
Pulley Data, Torques, Forces			
Travel Distance per Revolution	mm/rev (in/rev)	125 (4.92)	234.2 (9.22)
Pulley Diameter	mm (in)	39.8 (1.57)	74.5 (2.93)
Maximum Drive Torque ⁽³⁾	Nm (lb-in)	8.87 (79)	61.5 (544)
Maximum Belt Traction ⁽³⁾ (effective load)	N (lb)	668 (150)	1650 (371)
Repeatability ⁽⁴⁾	mm (in)	±0.02 (±0.008)	±0.02 (±0.008)

For the following deviations from the above standards, please contact Parker engineering:

- (1) Greater speeds and accelerations may be achieved.
- (2) Splicing possible for longer travel distances. This may cause reductions in effective load, drive torque, speed, acceleration, and repeatability.
- (3) Increased timing belt tension required.
- (4) Nominal value - component dependant. For improved repeatability consult factory.

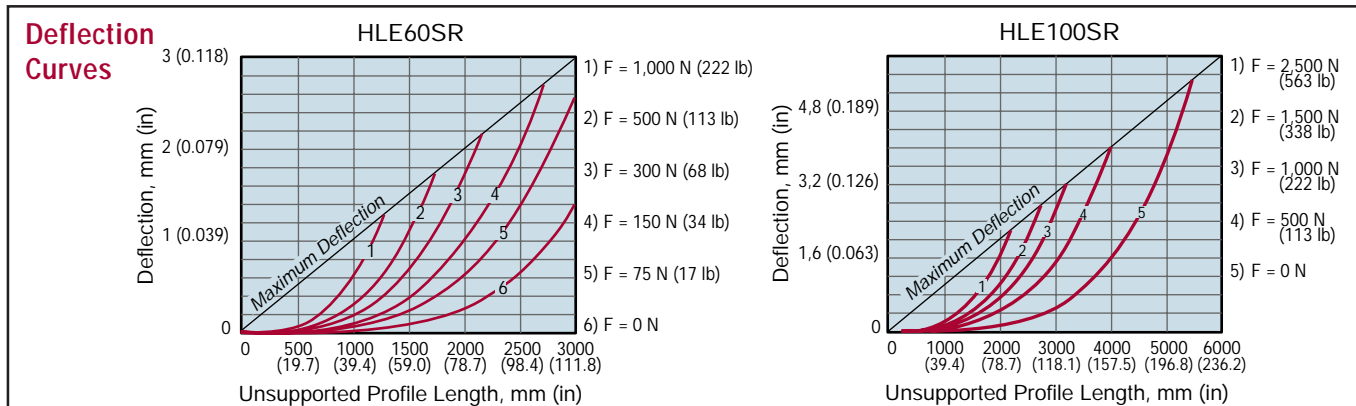

HLE-SR Performance Curves

The force and moment capabilities of the carriage and the timing belt are speed dependent. The load curves shown in the graphs are valid for a standard (NL order code) carriage. These curves show the allowable force or moment versus the nominal carriage life.

Refer to HLE-RB section for timing belt loading diagrams.

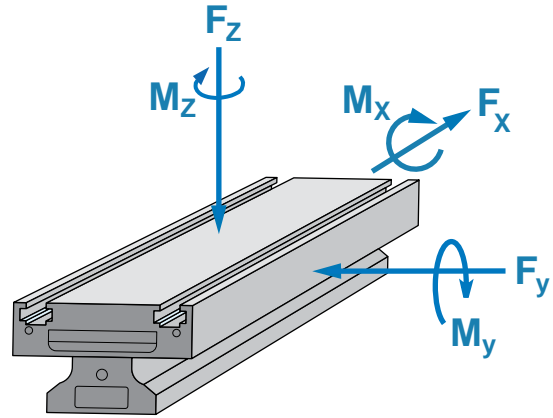

LEGEND	
Curve	Velocity
	m/sec. (in/sec.)
A	0.25 (10)
B	0.50 (20)
C	1.00 (40)
D	2.00 (80)
E	3.00 (120)

HLE-60SR

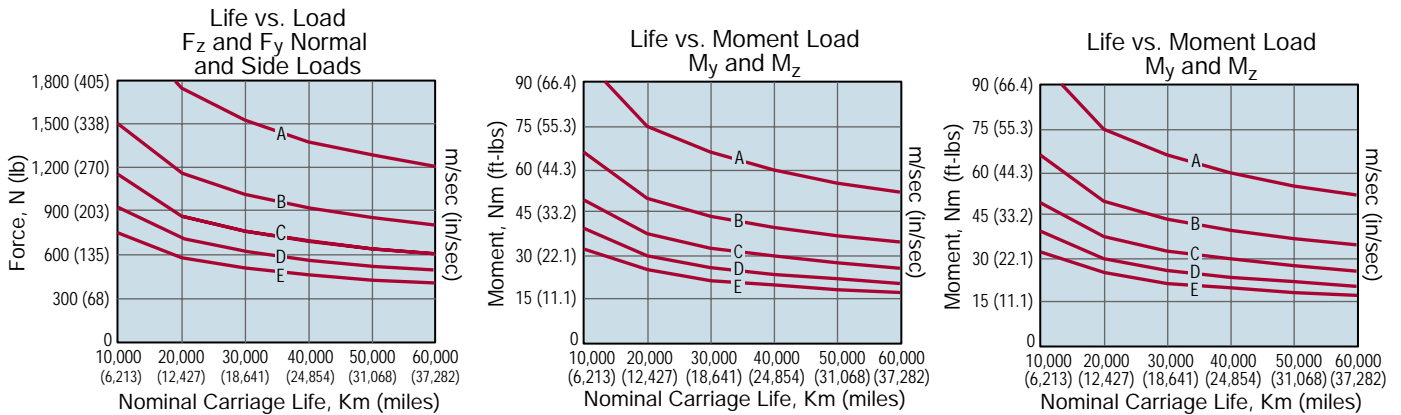

HLE-100SR

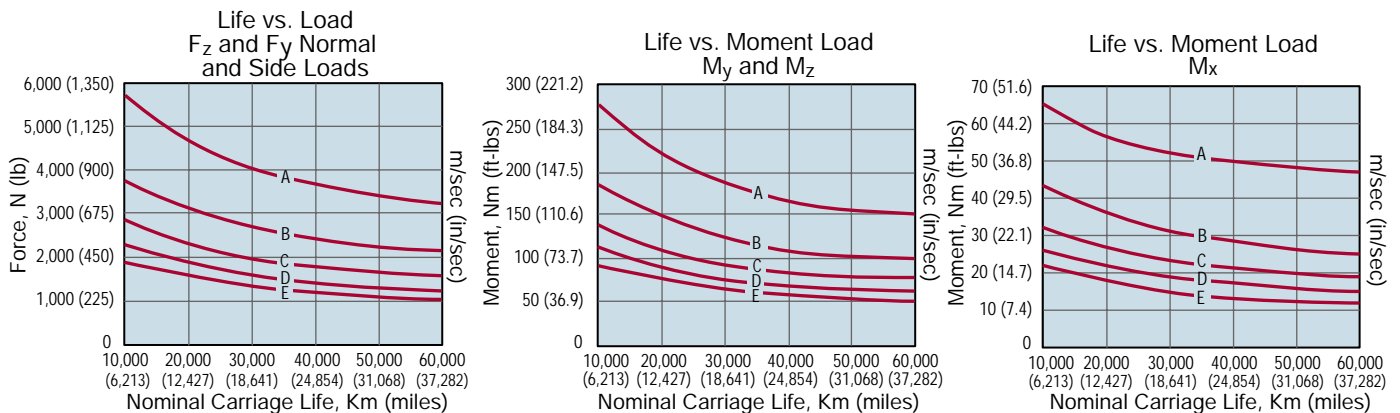

Belt Driven Modules

HLE60-SR Dimensions (mm)



Drive Unit

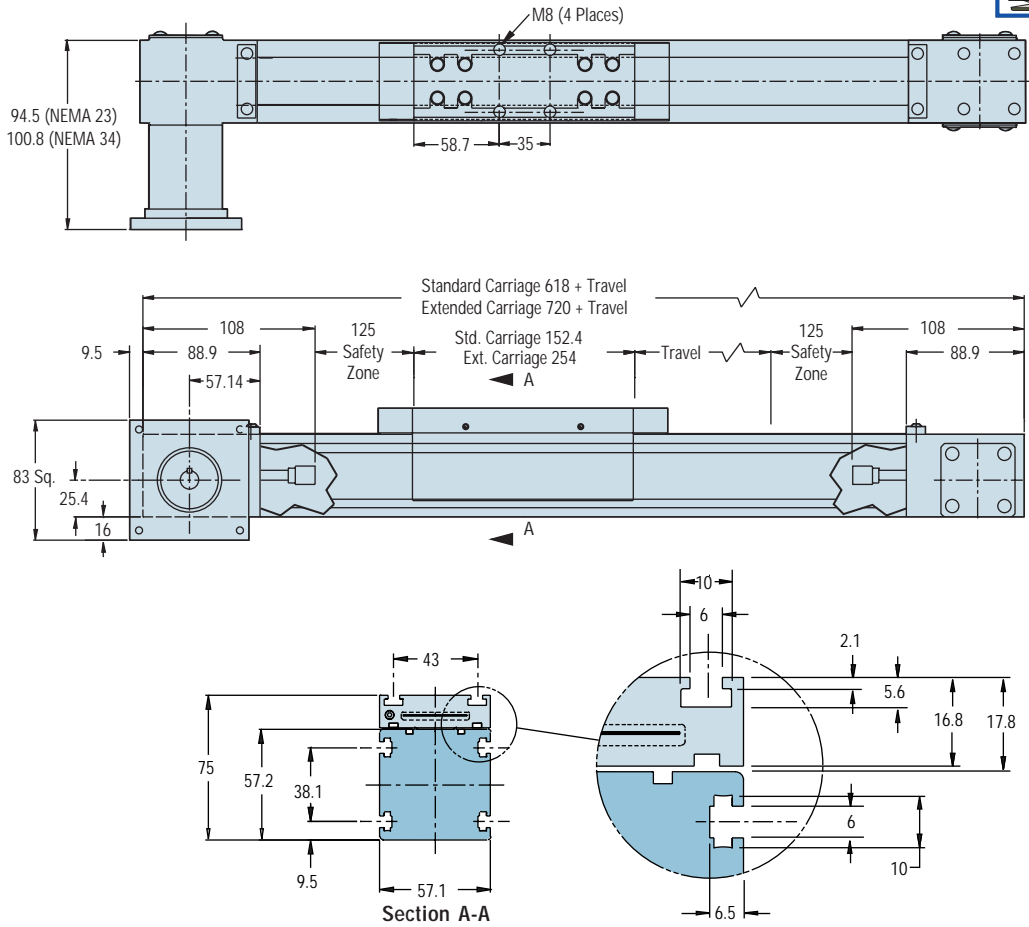

Drive Shaft Option

- WRO Shaft on Right
- WLO Shaft on Left
- WBO Shaft on Both Sides

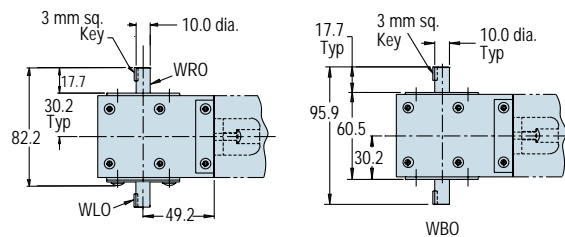

Idler Unit (top view)

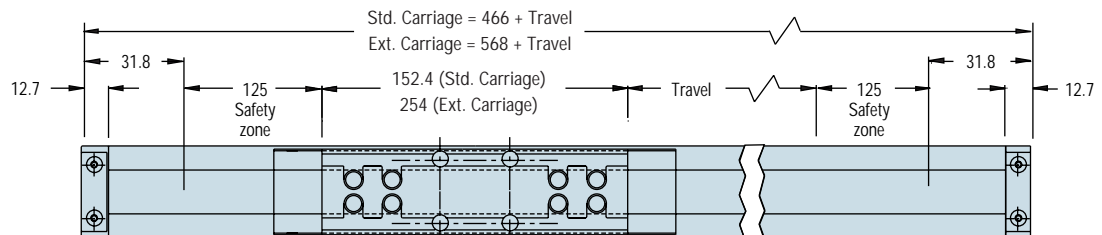

HLE100-SR Dimensions (mm)

Drive Unit

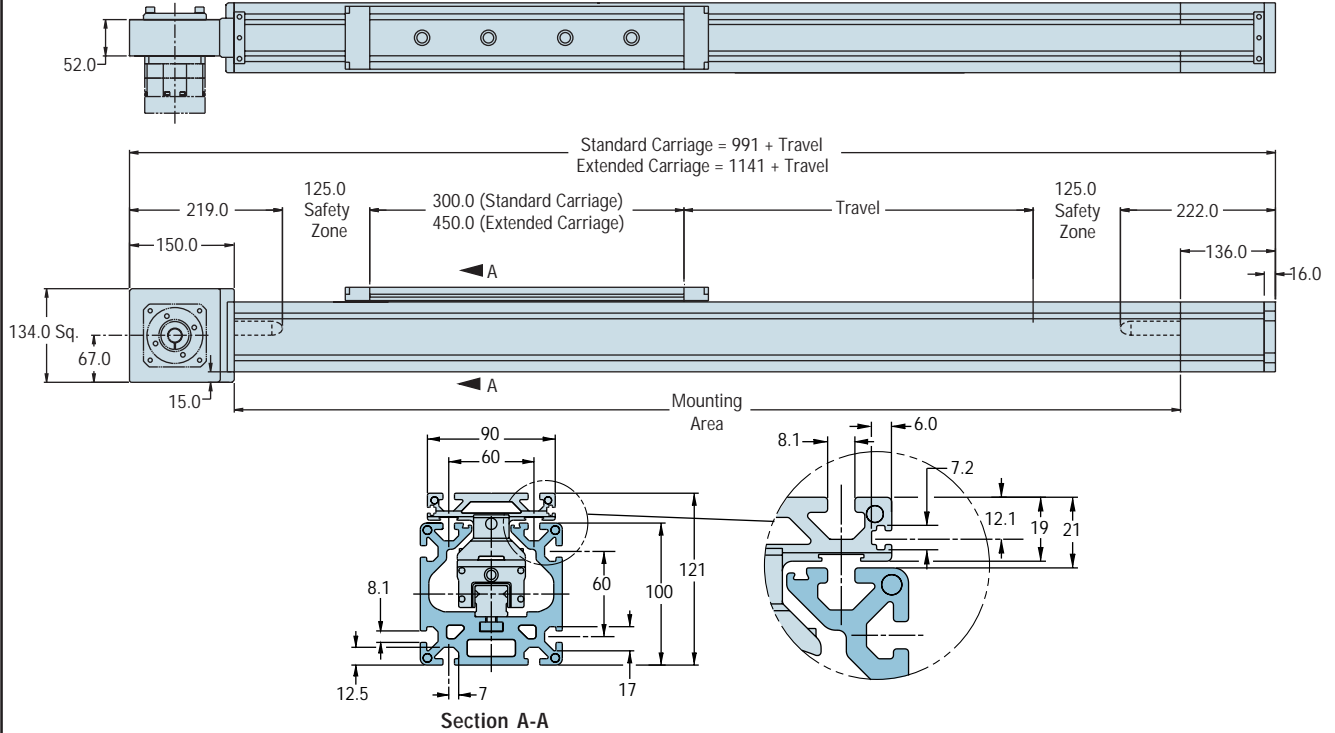

Drive Shaft Option

- WRO Shaft on Right
- WLO Shaft on Left
- WBO Shaft on Both Sides

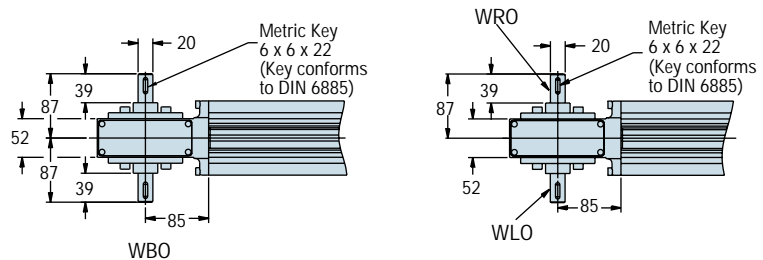

Idler Unit (top view)

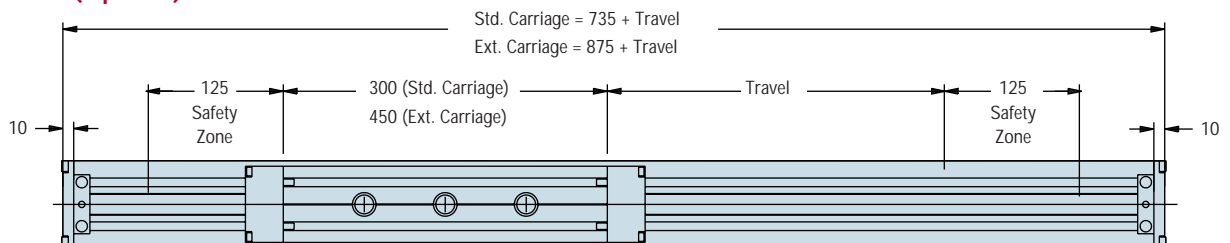

Belt Driven Modules

HLE60-SR How to Order

Order Example: HLE060 SR NL E 2000 DA0000 MBR SP5

Model Series HLE060

Bearing Type
SR SR

Carriage Type
Standard Carriage NL
Extended Carriage VL

Unit Type
Idler M
Timing Belt Drive, Nominal Thrust, Maximum Life E
Timing Belt Drive, Nominal Life, Maximum Thrust F

Travel Length
nnnn (nnnn=mm) nnnn

Drive Shaft Option - Center to Center
DA0000: No Drive Shaft - Single Axis or Idler Unit DA0000
DAnnnn (nnnn=mm) DAnnnn

Shaft Configuration Options
No Shaft, Idler Unit WOO
Shaft Left WLO
Shaft Right WRO
Double Shaft WBO
Motor Block Left MBL
Motor Block Right MBR
Motor Block Left, Shaft Right MLW
Motor Block Right, Shaft Left MRW
Double Axis, Motor Block Left DML
Double Axis, Motor Block Right DMR

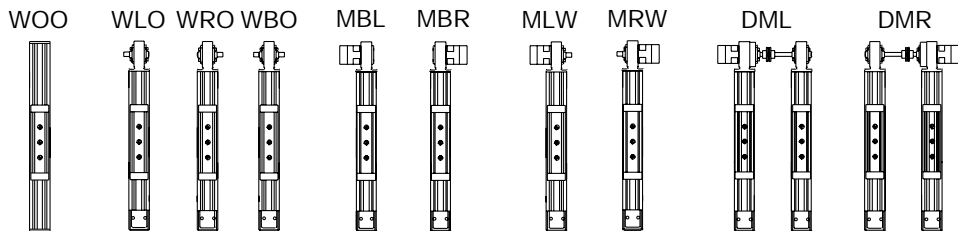

Drive Station Interface
Idler, Requires WOO Option SP0
No Motor Block, Requires WRO, WLO, or WBO SP1
Motor Block - NEMA 23 with .375 in. coupling SP2
Motor Block - NEMA 23 with .250 in. coupling SP3
Motor Block - NEMA 34 with .375 in. coupling SP4
Motor Block - NEMA 34 with .500 in. coupling SP5
Motor Block - NEMA 23 without coupling SP8
Motor Block - NEMA 34 without coupling SP9
Motor Block - PTN / PTR-060 with 14 mm coupling SP10
Motor Block - GTN / GTR with 16 mm coupling SP11

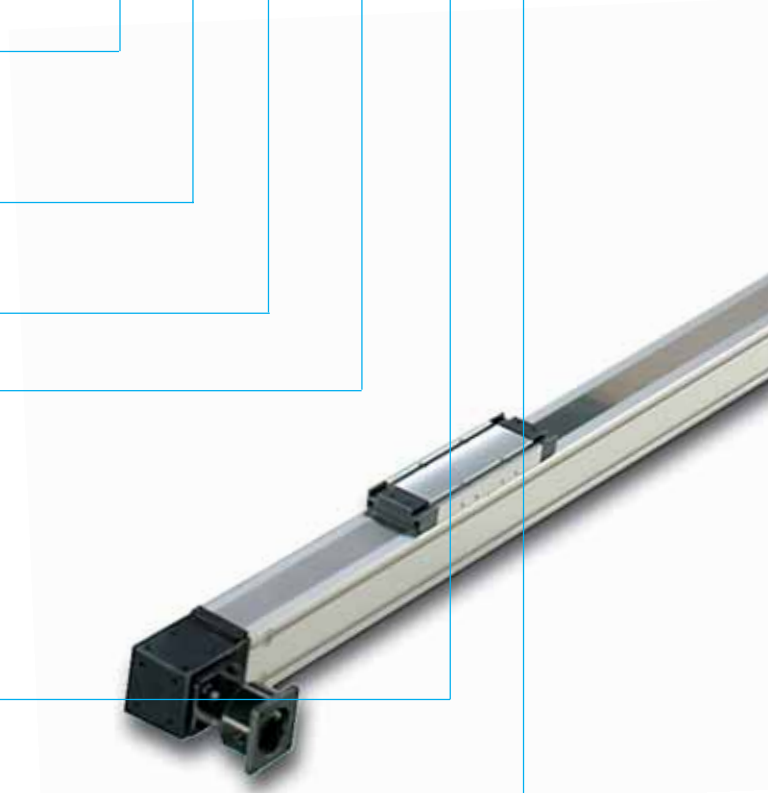

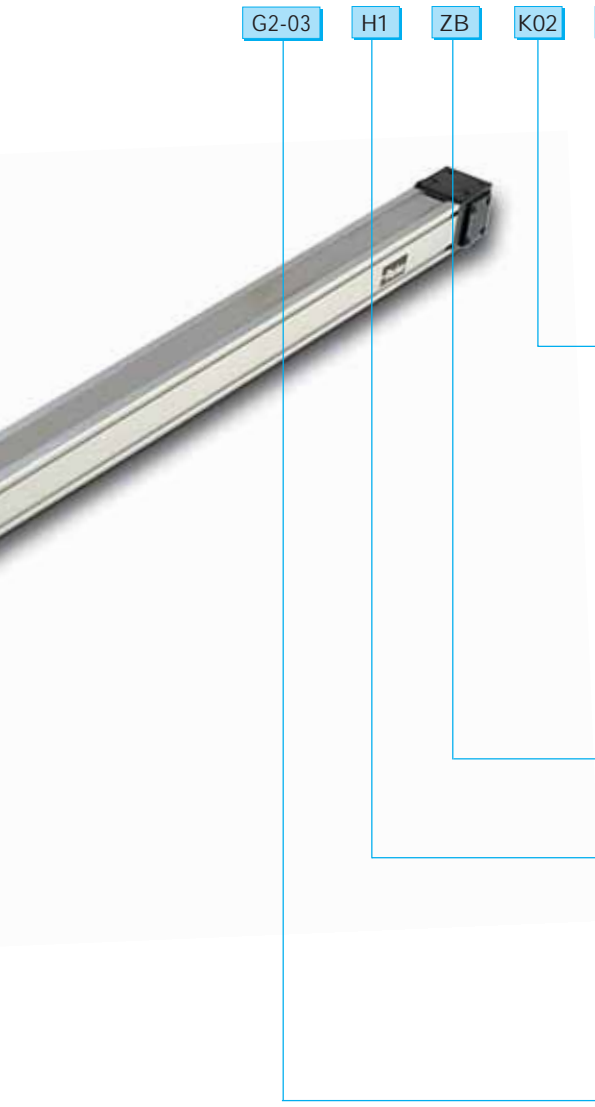

Limit/Home Switch Option

- LH0** No Limit Switch Assembly
- LH3** Three NPN Prox Switches, 10-30 VDC
- LH4** Three PNP Prox Switches, 10-30 VDC

Motor Kit Option

- K00** No Motor Kit
- K01** ES2*, OS2, S57*, SM230*, SE230* to PT-060
- K02** BE23* to PT-060
- K03** J034*, N034*, BE34*, TS3* to PT-060
- K04** RS3*, OEM83*, ES3*, ZETA83* to PT-060
- K05** J070*, N070* to PT-060
- K06** J070*, N070* to GT-070
- K07** SM230, SE230, ES2*, OS2, S57* to GT-070
- K08** SM, SE 231, 232, 233 to GT-070
- K09** J09*, N09* to GT-070

Strip Seal Option

- ZA** Unit with Strip Seal (IP30)
- ZB** Unit without Strip Seal

Mounting Orientation

- H1** Carriage Up
- H2** Carriage Down
- H3** Carriage on Side, Drive Station Up
- H4** Carriage on Side, Drive Station Down

Gearbox Option

- G0-00** No Gearbox
- G2-nn** PTN-060**
- G3-nn** PTR-060**
- G4-nn** GTN-070*
- G5-nn** GTR-070*

* Single stage ratios: 3, 4, 5, 8, 10 Dual stage ratios: 12, 15, 16, 20, 25
 **Single stage ratios: 3, 4, 5, 8 Dual stage ratios: 9, 12, 15, 16, 20, 25

Belt Driven Modules

HLE100SR How to Order

Order Example: HLE100 SR NL E 2000 DA0000 ARO SP2

Model Series HLE100

Bearing Type

SR SR

Carriage Type

Standard Carriage NL

Extended Carriage VL

Unit Type

Idler M

Timing Belt Drive, Nominal Thrust, Maximum Life E

Timing Belt Drive, Nominal Life, Maximum Thrust F

Travel Length

nnnn (nnnn=mm) nnnn

Drive Shaft Option - Center to Center

DA0000: No Drive Shaft - Single Axis or Idler Unit DA0000

DAnnnn (nnnn=mm) DAnnnn

Shaft Configuration Options

No Shaft, Idler Unit WOO

Shaft Left WLO

Shaft Right WRO

Double Shaft WBO

Reducer Left ALO

Reducer Right ARO

Reducer Left, Shaft Right ALW

Reducer Right, Shaft Left ARW

Double Axis, Drive Left DAL

Double Axis, Drive Right DAR

Motor Block Left MBL

Motor Block Right MBR

WOO WLO WRO WBO ALO ARO ALW ARW DAL DAR MBL MBR

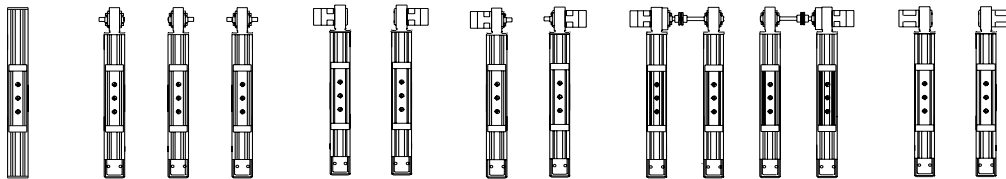

Drive Station Interface

Idler or Shaft Option SP0

Drive Housing for GTN /GTR-090 SP1

Drive Housing for GTN / GTR / PEN / PER-115 SP2

Motor Block - NEMA 34 with .500 in. coupling SP3

Motor Block - NEMA 34 with .375 in. coupling SP4

Motor Block - NEMA 34 without coupling SP5

Motor Block - with coupling for JO923 direct drive SP6

Motor Block - NEMA 42 with .625 in. coupling SP7

Motor Block - NEMA 42 without coupling SP8

Drive Housing for PEN / PER-090 SP9

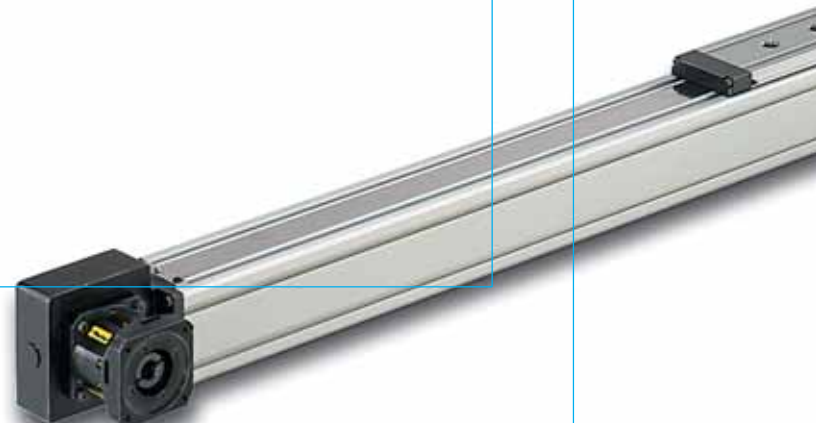

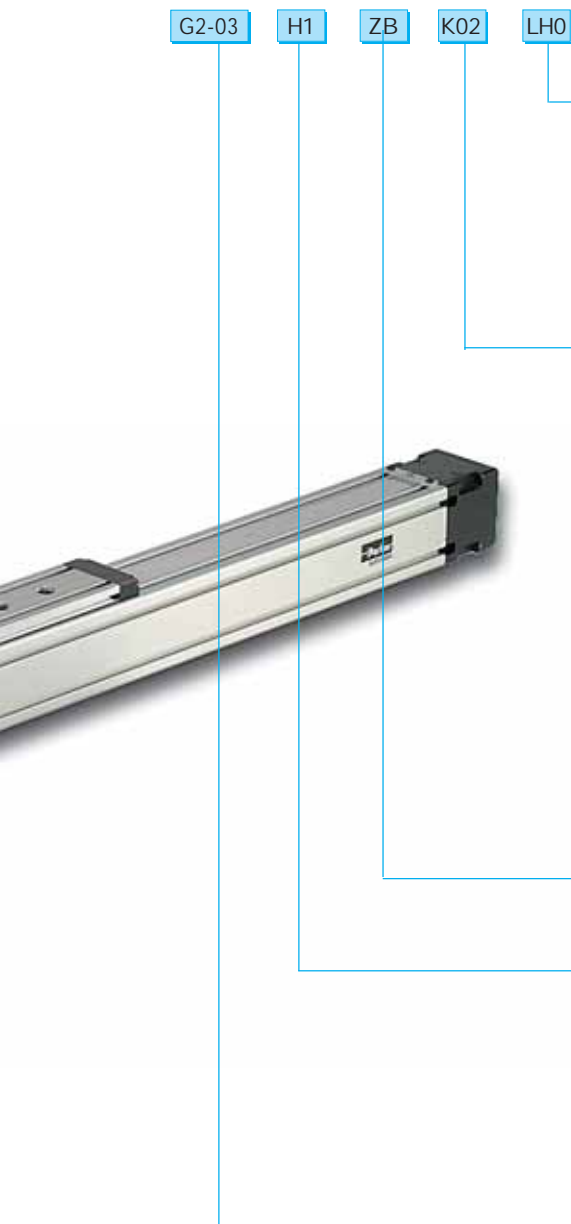

Limit/Home Switch Option

- LH0** No Limit Switch Assembly
- LH3** Three NPN Prox Switches, 10-30 VDC
- LH4** Three PNP Prox Switches, 10-30 VDC

Motor Kit Option

- K00** No Motor Kit
- K01** J034* , N034* , BE34* , TS3* to GTN , PEN-090
- K02** J070* , N070* to GTN , PEN-090
- K03** J090* , N090* to GTN , PEN-090
- K04** M105* to GTN , PEN-090
- K05** ES3* , OEM83-* , ZETA83-* , S83-* , RS3* to GTN,PEN-0-90
- K06** J034* , N034* , BE34* , TS3* to GTN,PEN-115
- K07** J090* , N090* to PE-115 or GTN,PEN-115
- K08** M105* to PE-115 or GTN,PEN-115
- K09** ES3* , OEM83-* , ZETA83-* , S83-* , RS3* to GTN,PEN-115
- K10** RS42, RE42, S106-205 to GTN,PEN-115
- K11** S106-178, S106-250 to GTN,PEN-115
- K12** M145 to GTN,PEN-115ZETA57-83-MO-S

Strip Seal Option

- ZA** Unit with Strip Seal (IP30)
- ZB** Unit without Strip Seal

Mounting Orientation

- H1** Carriage Up
- H2** Carriage Down
- H3** Carriage on Side, Drive Station Up
- H4** Carriage on Side, Drive Station Down

Gearbox Option

- G0-00** No Gearbox
- G2-nn** PEN-090**
- G3-nn** PER-090**
- G4-nn** PEN-115**
- G5-nn** PER-115**
- G6-nn** GTN-090*
- G7-nn** GTR-090*
- G8-nn** GTN-115*
- G9-nn** GTR-115*

* Single stage ratios: 3, 4, 5, 8, 10 Dual stage ratios: 12, 15, 16, 20, 25
 **Single stage ratios: 3, 4, 5, 8 Dual stage ratios: 9, 12, 15, 16, 20, 25

Belt Driven Modules

HLE-Z Series

Features

- ❑ Long travels – selectable up to 50 meters
- ❑ Load capacities up to 600 kg
- ❑ Up to 5 meters/sec. velocity
- ❑ ± 0.05 mm positional repeatability
- ❑ Rack-and-Pinion drive mechanism
- ❑ Independent multiple carriages on single rail
- ❑ Roller wheel bearings for smooth high speed linear motion



Housing

The HLEZ housing is a lightweight, compact and self-supporting extruded aluminum section. It is available in a 150 x 150 mm cross section. T-slots along the length are utilized for clamping mechanical components joining units and attaching sensors and mechanical switches.

Load Attachment Plate

T-slots integrated on the top of this plate facilitate the assembly of attachments to the HLEZ. Utilization of these T-slots together with standard clamping profiles (described later) enables easy straightforward construction of multi-axis systems.

Drive Module

The drive module fitted on either side of the load attachment plate, employs a unique pinion style drive mechanism. A Parker servo motor combined with resolver and appropriate planetary gearbox forms an optimum drive for dynamic and accurate applications.

Cable Carrier

Cable Carrier (not shown) is required. Consult factory before making final selection.

Cover Profiles

The cover profiles are used to create cable routing ducts and enhance appearance.

Carriage

Lightweight, rigid carriage with roller wheel bearings on eccentric axles to eliminate play on all sides. Each wheel is comprised of a radial ball bearing with a tough polyamide tread to provide high mechanical efficiency and virtually wear-free operation. The carriage can be ordered as a standard or an extended length. Longer or custom carriages are also offered.

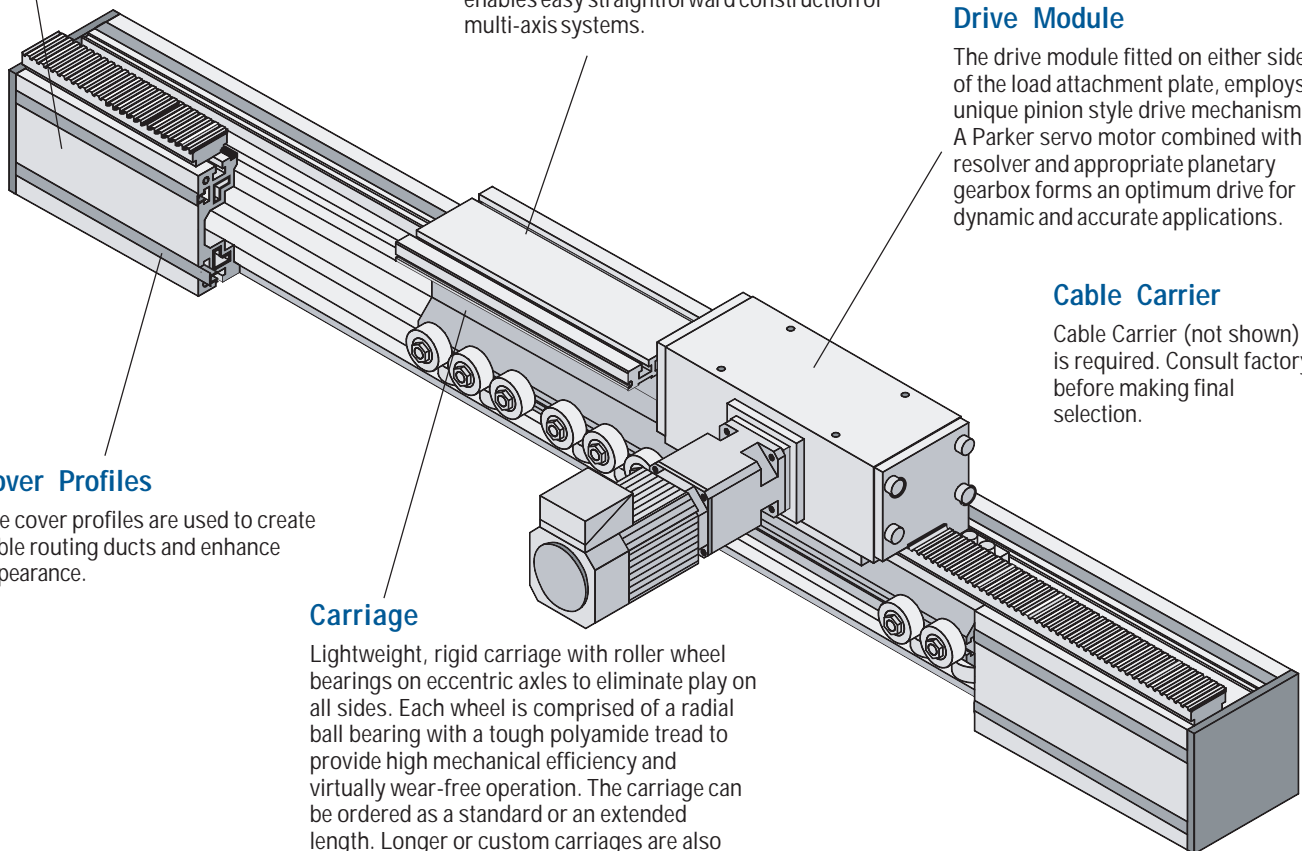

HLE-Z Series

The “endless” linear unit is designed for guiding, transporting or positioning payloads over long travel distances with high rigidity and accuracy. This is accomplished by incorporating Parker’s uniquely designed rack-and-pinion based drive system with an HLE150 linear module housing. The exceptional dynamic characteristics inherent to these units make them well suited for applications requiring high speed linear translation and positioning over long travel distances.

The carriage drive mechanism is independent of the housing mechanics. As a result, multiple carriage applications, where several carriages can be positioned on a single unit independently of each other, are easily accommodated. Mechanical compatibility with the HLE series and other Parker components permit efficient, cost-effective construction of gantry robots and automated systems.

HLE-Z Drive Principle

The HLEZ drive offers all the advantages of a rack drive, but without the usual drawbacks. The short timing belt (which is independent of travel length) reduces belt stretching to an absolute minimum. The lateral deflection roller pretensions the system and thereby removes backlash. “Hold down” rollers ensure that sufficient teeth always remain in mesh. The combination of a steel reinforced polyurethane timing belt and an aluminum rack-and-pinion is a safe and clean drive which requires no lubrication.

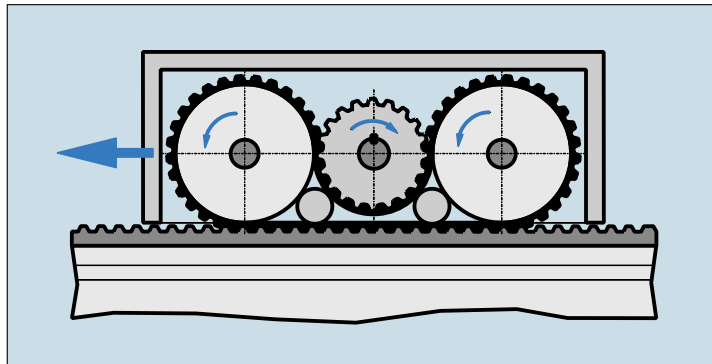

Combined Technology
<p>Linear actuator and rack offers the following advantages:</p> <ul style="list-style-type: none"> • High dynamic response, even over long travel distances, due to: <ul style="list-style-type: none"> • the short timing belt, regardless of travel length • the lightweight carriage • the backlash-free drive • High positional repeatability, regardless of stroke length • Option of several carriages per linear unit, making overlapping strokes along a single axis possible • Low preventative maintenance intervals

Typical Applications
<p>As part of advanced, cost-effective construction of machines and handling systems:</p> <ul style="list-style-type: none"> • Materials handling: palletization, depalletizing, feeding, part removal • Cleanroom technology: wafer transport, water coating • Warehouse technology: parts picking, storage and retrieval • Machine tool automation: workpiece loading and unloading, tool changing • Construction: formwork, placing reinforcing steel bars in concrete • Process engineering: painting, coating, bonding • Testing technology: guiding ultra-sonic sensors, laboratory equipment

HLE-Z Series Specifications

Characteristic	Units	HLEZ150
Unit Weight (basic unit without stroke)		
Standard Carriage, S	kg (lb)	53.0 (116.9)
Extended Carriage, E	kg (lb)	61.0 (134.5)
Carriage Weight		
Standard Carriage, S	kg (lb)	25.7 (56.7)
Extended Carriage, E	kg (lb)	29.7 (65.5)
Weight (per meter) of additional travel length	kg/m (lb/ft)	23.9 (16.6)
Moment of Inertia (related to the drive shaft)		
Standard Carriage, S	kg-cm ² (lb-in ²)	325.0 (111.1)
Extended Carriage, E	kg-cm ² (lb-in ²)	363.4 (124.3)
Travel and Speed		
Maximum Speed	m/s (in/s)	5 (197)
Maximum Acceleration	m/s ² (in/s ²)	10 (393)
Maximum Travel ⁽¹⁾ , NL carriage	m (in)	8.8 (350)
Maximum Travel ⁽¹⁾ , VL carriage	m (in)	8.7 (344)
Maximum Travel - (with splices)	m (in)	50 (1969)
Geometric Dat		
Cross Section, Square	mm (in)	150.0 (5.91)
Moment of Inertia I _x	cm ⁴ (in ⁴)	1940.0 (46.61)
Moment of Inertia I _y	cm ⁴ (in ⁴)	2147.0 (51.58)
Moment of Elasticity	N/mm ² (lb/in ²)	0.72 x 10 ⁵ (0.1044 x 10 ⁶)
Pulley Data, Torques, Forces		
Travel Distance per Revolution	mm/rev (in/rev)	200.0 (7.87)
Pulley Diameter	mm (in)	63.6 (2.51)
Maximum Drive Torque	Nm (lb-in)	64.0 (566)
Maximum Belt Traction (effective load)	N (lb)	refer to force (Fx) chart on next page
Repeatability ⁽²⁾	mm (in)	±0.05 (±0.002)

For deviations from the above standards, please contact Parker engineering:

(1) Splicing possible for longer travel distances.

(2) Applies to the linear actuator with drive module, without drive.

Technical data issued 6/99, safety factor taken into consideration S=1. Data applies to a temperature range of between -10°C and +40°C.

HLE-Z Performance Curves

The forces and torque ratings of the carriage are speed dependent. The curves shown in the graphs apply to a standard carriage (S).

With the extended carriage (E), all the values except for F_x (load-bearing capacity of timing belt) can be doubled if the load is applied equally to both halves of the carriage or distributed uniformly along its entire length. The curves show the maximum load-bearing capacity of a carriage in one direction of force or torque. If several loads are applied in different directions, the values given by the curves must be derated, or the load or speed should be reduced if necessary.

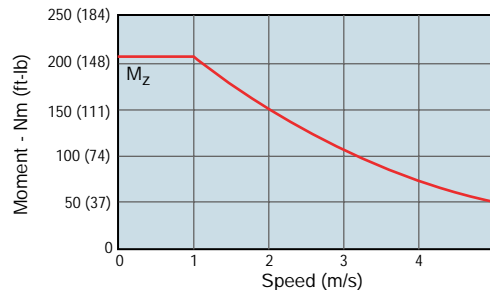
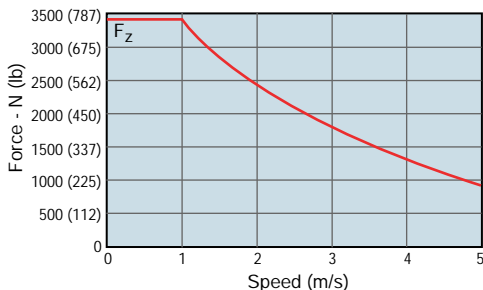
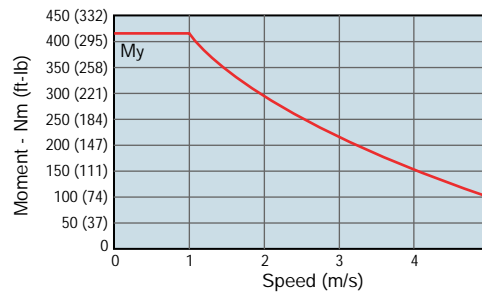
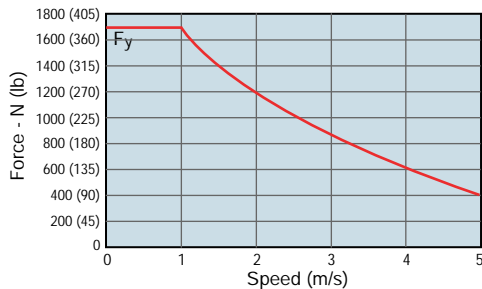
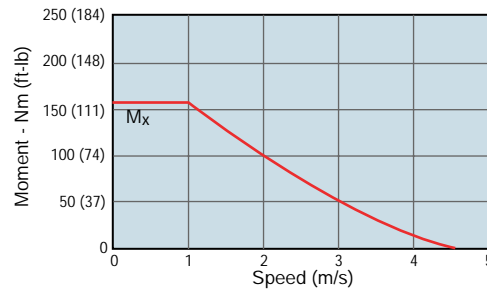
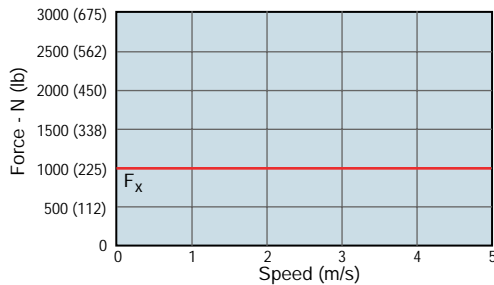
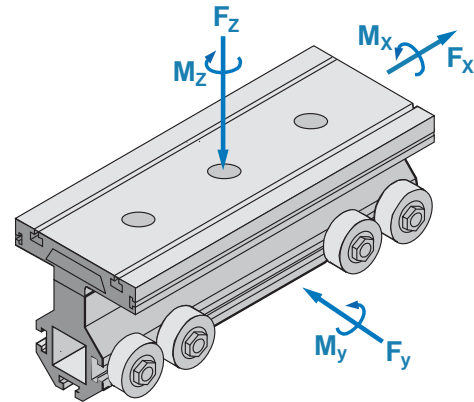

Belt Driven Modules

HLE-Z Series Dimensions (mm)



HLE-Z150

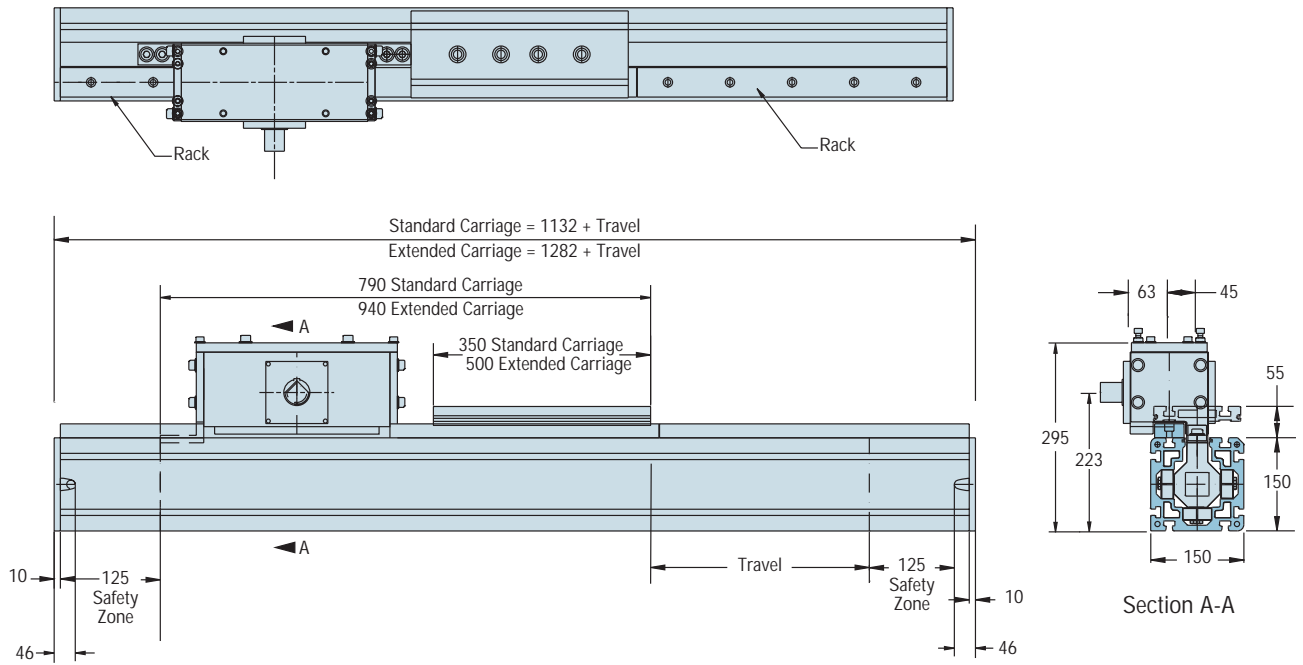

Note: Cable Carrier required (not shown) – consult factory before making final selection.

HLE-Z Series How to Order

	HLE	Z	150	E	P	1000	DL	K	G4-05	N	N	N	KO8	LH0
Model Series	HLE													
Drive System		Z												
Rack-and-Pinion		Z												
Idler Unit		N												
Model Size			150											
150			150											
Carriage				S										
Standard Carriage				S										
w/ Load Attachment Plate														
Extended Carriage				E										
w/ Load Attachment Plate				E										
Guide System					P									
Polyamide Wheels					P									
Travel						nnnn								
Specify Desired Travel (mm)						nnnn								
Drive Options*							ND							
No Shaft – Idler Unit							ND							
Shaft on Left							SL							
Shaft on Right							SR							
Gearbox on Left							DL							
Gearbox on Right							DR							
<small>*For definition of on left/on right: see figure below.</small>														
Drive Station Interface								I						
No Flange - Idler Unit								I						
Flange Suitable for									K					
115 mm Gearbox									K					
Flange Suitable for										L				
142 mm Gearbox										L				
Gearbox Option														
No Gearbox									G0-00					
Customer Supplied									G1-nn					
PEN-115*									G2-nn					
PER-115*									G3-nn					
GTN-115*									G4-nn					
GTR-115*									G5-nn					
GTN-142*									G6-nn					
GTR-142*									G7-nn					
* Single stage ratios: 3, 4, 5, 8, 10 Dual stage ratios: 12, 15, 16, 20, 25														
**Single stage ratios: 3, 4, 5, 8 Dual stage ratios: 9, 12, 15, 16, 20, 25														
<p>Limit, Home Switch Options</p> <p>LH0 No limit switch assembly</p> <p>LH1 Three mechanical switches</p> <p>LH2 Two mechanical switches, 1 prox</p> <p>LH3 Three NPN prox switches, 10-30 VDC</p> <p>LH4 Three PNP prox switches, 10-30 VDC</p> <p>Motor Kit Option</p> <p>K00 No Motor Kit</p> <p>K06 J034*, N034*, BE34*, TS3* to GT, PE-115</p> <p>K07 J090*, N090* to GT, PE-115</p> <p>K08 M105* to GT, PE-115</p> <p>K09 ES3*, OEM83*, ZETA83*, S83*, RS3* to GT, PE-115</p> <p>K10 RS42, RE42, S106-205 to GT, PE-115</p> <p>K11 S106-178, S106-250 to GT, PE-115</p> <p>K12 M145 to GT, PE-115</p> <p>K13 M145 to GT, PE-142</p> <p>Strip Seal Cover</p> <p>N Without cover (standard)</p> <p>Material</p> <p>N Standard – version</p> <p>V Corrosion resistant version (consult factory)</p> <p>Linear Encoder</p> <p>N Without linear encoder (standard)</p> <p>L With linear encoder (consult factory)</p>														

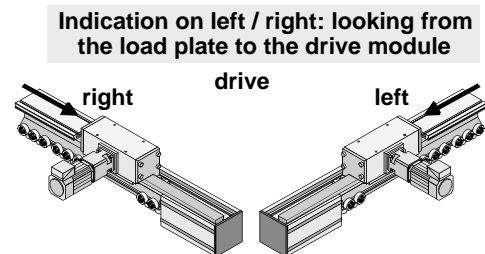

Belt Driven Modules

HZR Series

Features

- ❑ Designed as a vertical axis unit
- ❑ Load lifting capacities up to 150 kg
- ❑ Velocity up to 5 meters/sec.
- ❑ Positional repeatability of ± 0.2 mm
- ❑ Torsion-resistant housing
- ❑ Roller wheel bearings for smooth vertical motion
- ❑ High vertical acceleration

The HZR is a rugged vertical axis unit unique to the high speed automation industry. It is specifically designed to satisfy the mechanical demands placed on the vertical axis of a multi-axis gantry robot – utilized for high throughput lifting and transporting of heavy or bulky loads.

The payload is supported by a high strength extruded aluminum profile which is lifted and guided

through a torsion-resistant cast aluminum housing. Maintenance-free, heavy duty polyamide bearing wheels evenly distribute and support the high forces induced by rapid horizontal acceleration of the load. A wear-free, steel cord reinforced timing belt transmits large traction forces to provide high accelerations and lifting capability in the vertical direction.

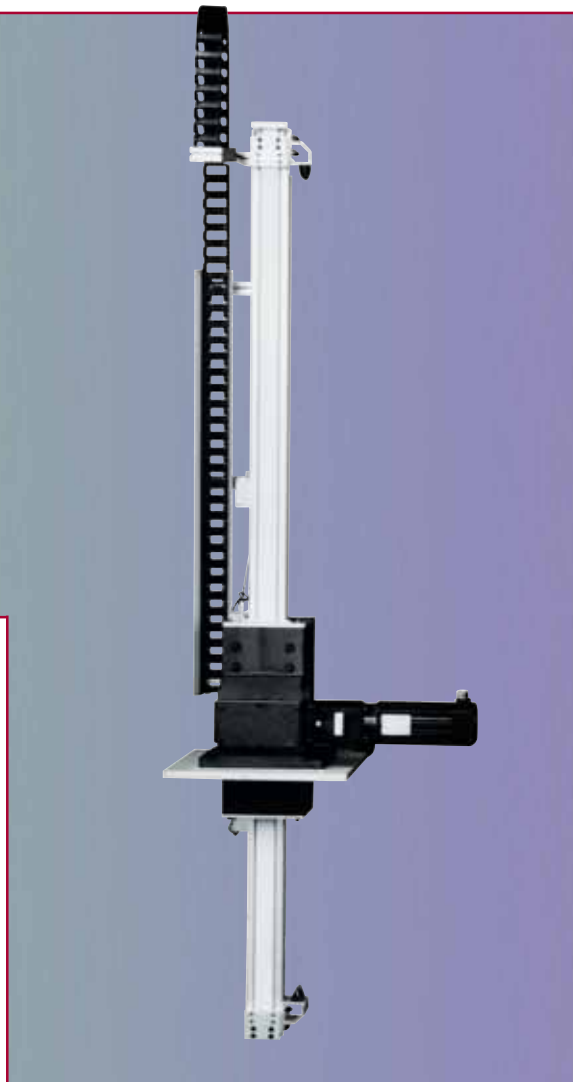

Typical Fields of Application

Materials handling: palletization, feeding, removal

Textile machinery building: crosscutting, slitting and stacking, quilting, seam stitching

Process engineering: painting, coating, bonding

Storage technology: commissioning, inventory

Machine tool building: workpiece loading, tool changing

Testing technology: guiding ultrasonic sensors

HZR Series Specifications

Characteristic	Units	HZR50		HZR80	HZR100
		P(Standard)	E(Extended)		
Unit Weight					
Basic Unit (based on 1 meter travel)	kg (lb)	15.3 (33.73)	17.2 (37.92)	37 (81.8)	60 (132.3)
Weight of additional length	kg/m (lb/ft)	2.9 (1.95)	2.9 (1.95)	7.4 (4.9)	10.2 (6.85)
Moment of Inertia (based on 1 meter travel)					
Inertia reflected to drive pulley	kg-cm ² (lb-in ²)	66.11 (22.58)	66.51 (22.72)	250 (85.4)	357 (122.0)
Travel and Speed¹					
Maximum Speed	m/s (in/s)	5 (200)	5 (200)	5 (200)	5 (200)
Maximum Acceleration	m/s ² (in/s ²)	5 (197)	5 (197)	10 (393)	10 (393)
Maximum Travel	m (in)	1.5 (59.1)	1.5 (59.1)	1.5 (59.1)	2.0 (78.7)
Geometric Data					
Cross Section (square profile)	mm (in)	50 (1.97)	50 (1.97)	80 (3.2)	100 (3.9)
Moment of Inertia I _x	cm ⁴ (in ⁴)	29.9 (0.72)	29.9 (0.72)	187.1 (4.5)	383.3 (9.2)
Section Modulus, W	cm ³ (in ³)	29.9 (1.82)	29.9 (1.82)	46.7 (2.85)	76.6 (4.67)
Pulley Data, Torques, Forces					
Travel Distance per Revolution	mm/rev (in/rev)	180 (7.09)	180 (7.09)	240 (9.45)	240 (9.45)
Pulley Diameter	mm (in)	57.3 (2.26)	57.3 (2.26)	76.4 (3.01)	76.4 (3.01)
Maximum Drive Torque	Nm (lb-in)	47 (416.3)	47 (416.3)	108 (956.7)	168 (1488.1)
Static Load	kg (lb)	45 (99.2)	45 (99.2)	75 (165)	150 (331)
Maximum Belt Traction (effective load)	N (lb)	1654 (371.8)	1654 (371.8)	2822 (635)	4410 (992)
Repeatability	mm (in)	±0.2 (±0.008)	±0.2 (±0.008)	±0.2 (±0.008)	±0.2 (±0.008)

¹ For higher speeds, accelerations or longer travel consult Parker Application Engineering for assistance.



HZR Series Performance Curves

Force and Moment Loading

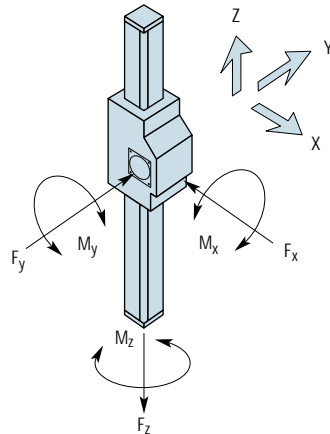

The software package "DimAxes" is available for determination of precise carriage loading. Visit www.parkermotion.com to request a Gantry Robot CD.

HZR50 Series

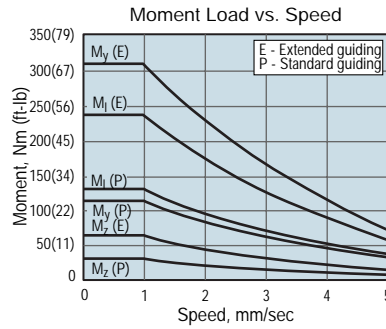
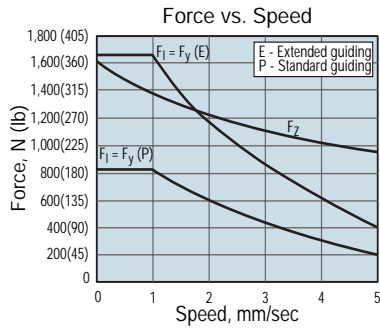

Extension Loads

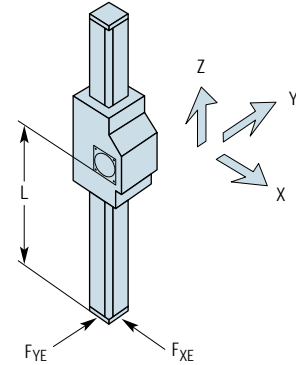

HZR50 Series

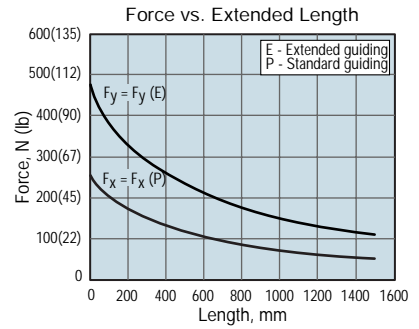

HZR80 Series

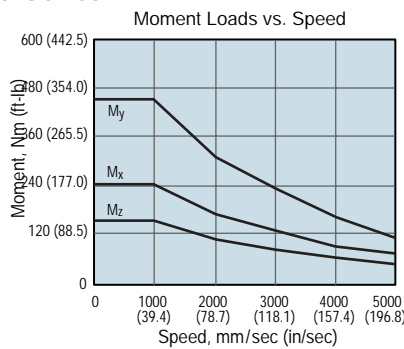
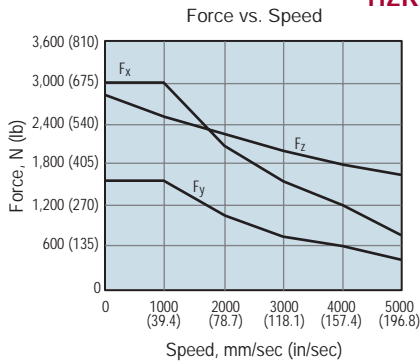

HZR80 Series

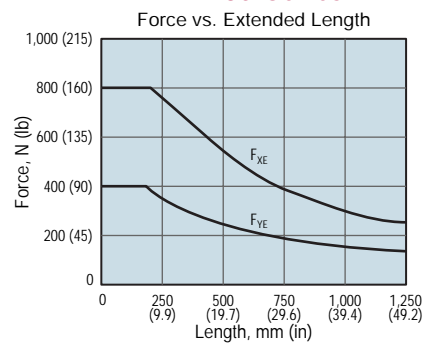

HZR100 Series

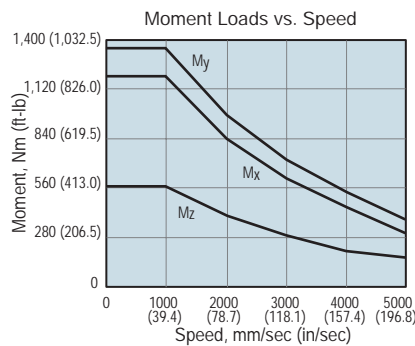
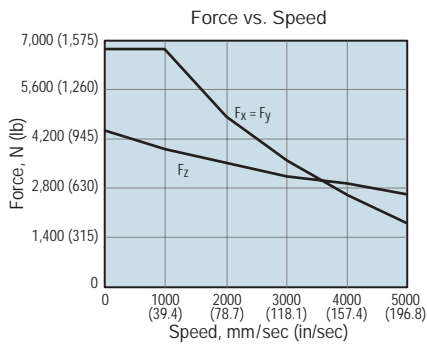

HZR100 Series

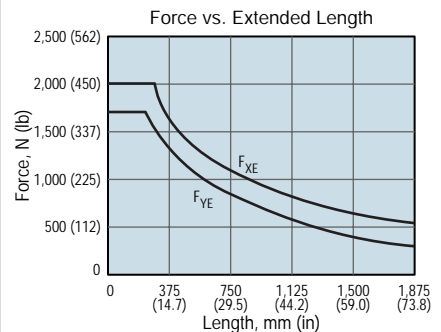



HZR Series Dimensions (mm)

HZR50 Series

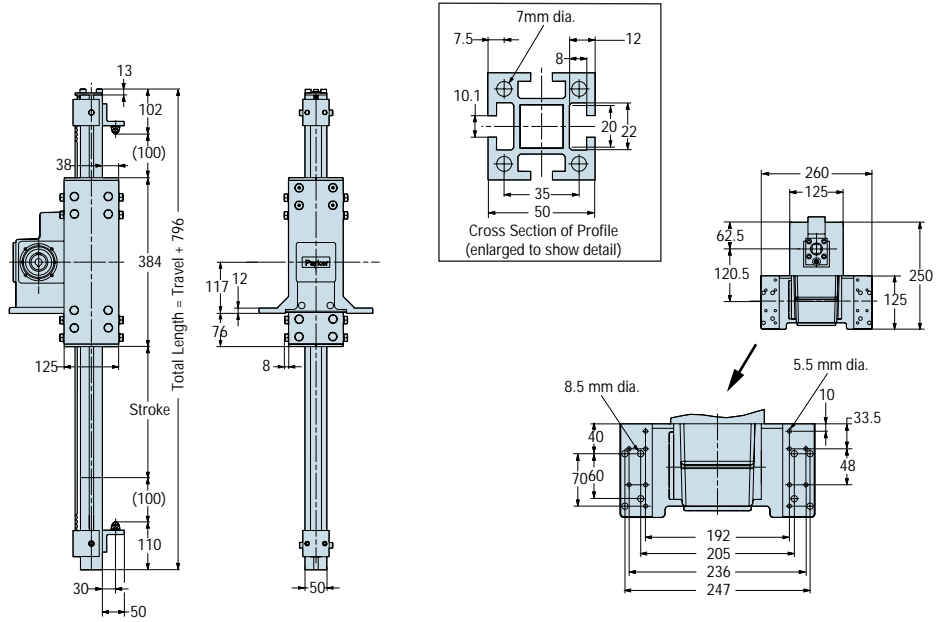

HZR80 Series

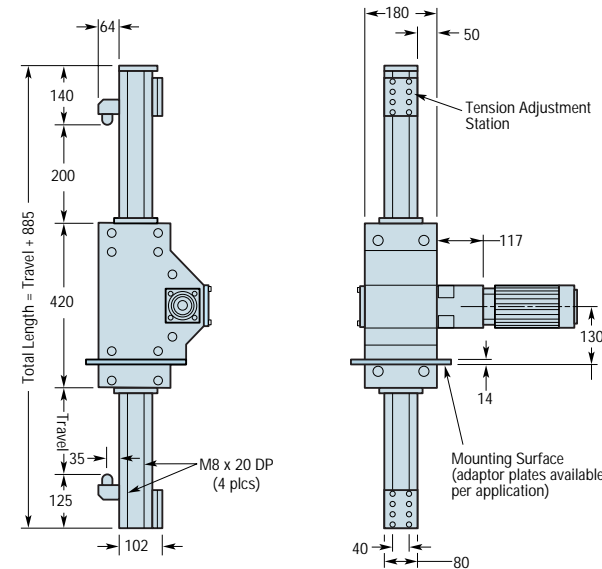
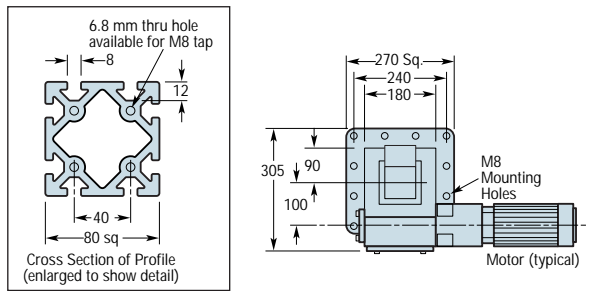

HZR100 Series

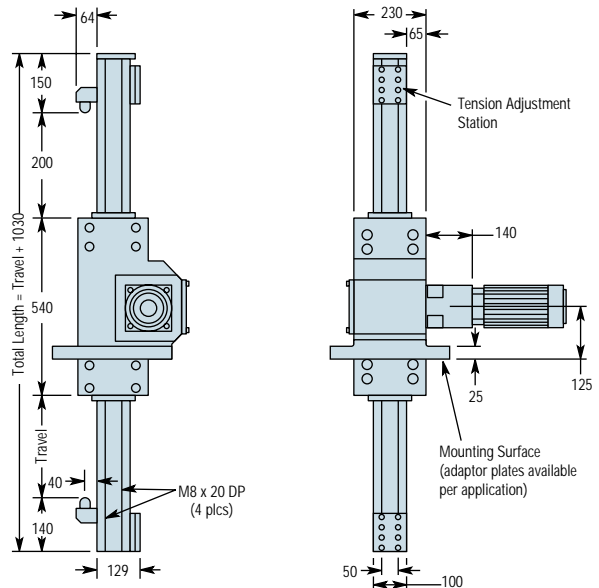
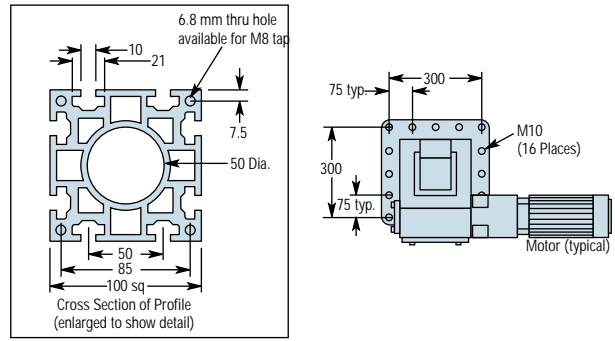

Belt Driven Modules



HZR50, HZR80, & HZR100 Series - How to Order

Order Example

HZR80 1000 A SP2 ARO G2-03

Model Series HZR50
 HZR80
 HZR100

Table Travel nnnn= mm nnnn

Mounting Flange Options

No Mounting Flange A
 HZR mounting to HPLA80 B
 HZR mounting to HLE100 C
 HZR mounting to HPLA120 D
 HZR mounting to HLE150 E

Drive Station Interface

Drive Housing set-up for GTN090 (HZR50&80) SP0
 Drive Housing set-up for GTN070(HZR50) SP2
 Drive Housing set-up for PEN090(HZR50&80) SP3
 Drive Housing set-up for GTN/PTN115(HZR80&100) SP9

Orientation Options

Gearbox Right ARO
 Gearbox Left ALO

Gearbox Option

No Gearbox G0-00
 Customer Supplied G1-nn
 GTN070* G2-nn
 GTN090* G3-nn
 GTN115* G4-nn
 PEN090** G5-nn
 PEN115** G6-nn

* Single stage ratios: 3, 5, 8 Dual stage ratios: 12, 15, 16, 20, 25
 **Single stage ratios: 3, 5, 8, 10 Dual stage ratios: 9, 12, 15, 16, 20, 25

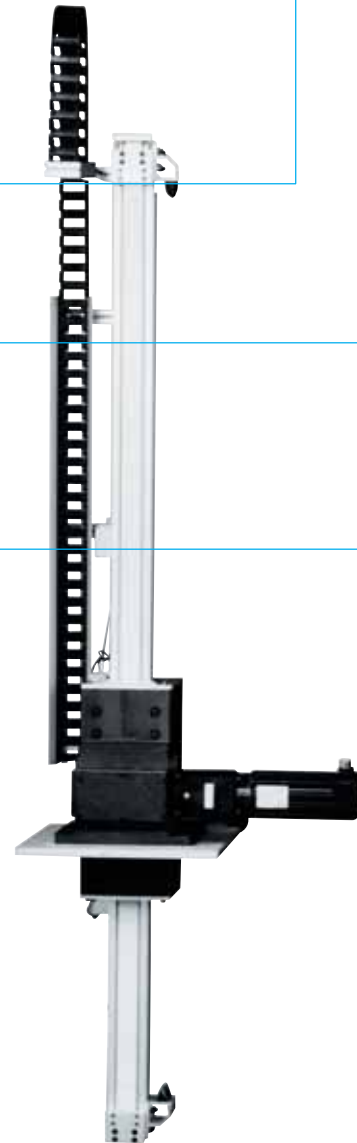

K02 LH1 E

Extended Option

E 16 Additional rollers (HZR50 only)

Limit Switch Assembly

- LH0 No Switch Assembly
- LH1 Three mechanical switches, w/ 1 NO and 1 NC contact per switch (HZR80,100)
- LH2 Two mechanical switches and 1 NPN proximity switch (HZR80,100)
- LH3 Three NPN proximity switches NO/NC, 10-30 VDC (HZR80,100)
- LH4 Three PNP proximity switches NO/NC, 10-30 VDC (HZR80,100)
- LH5 Three NPN proximity switches NO 'Home'; NC Travel Limits 10-30 VDC (HZR50 only)
- LH6 Three NPN proximity switches NO 'Home'; NC Travel Limits 10-30 VDC (HZR50 only)

Motor Kit Option

- K00 No Motor Kit
- K01 J034*, N034*, BE34*, TS3* to GTN, PEN-090
- K02 J070*, N070* to GTN, PEN-090
- K03 J090*, N090* to GTN, PEN-090
- K04 M105* to GTN, PEN-090
- K05 ES3*, OEM83-*, ZETA83-*, S83-*, RS3* to GTN,PEN-0-90
- K06 J034*, N034*, BE34*, TS3* to GTN,PEN-115
- K07 J090*, N090* to PE-115 or GTN,PEN-115
- K08 M105* to PE-115 or GTN,PEN-115
- K09 ES3*, OEM83-*, ZETA83-*, S83-*, RS3* to GTN,PEN-115
- K10 RS42, RE42, S106-205 to GTN,PEN-115
- K11 S106-178, S106-250 to GTN,PEN-115
- K12 M145 to GTN,PEN-115
- K13 J070*, N070* to GTN-070
- K14 SM230, SE230, ES2*, OS2, S57-* to GTN-070
- K15 SM,SE 231, 232, 233 to GTN-070 J09*, N09* to GTN-070 J090*
- K16 N090* to GTN-070

Belt Driven Modules

Additional Capabilities

Features

- Motors, Drives and Controls
- Extended Travels
- Rotary Motion Modules
- Clean Room Preparations
- External Position Feedback
- Vertical Axis Brakes
- End Effectors
- Protective Guarding
- Custom Support Structures

Parker's seven standard gantry systems provide cost-effective, easy to integrate solutions that satisfy the vast majority of automation requirements. In addition to these standard gantry systems, Parker offers products with additional capabilities to fulfill the needs of special applications. Our engineering skill and manufacturing expertise have integrated these products into custom-tailored gantry solutions which have successfully addressed the most unique and exacting requirements of machine builders and integrators around the world.



HTR Telescopic Vertical Module

The HTR is a telescopic belt driven module designed to provide a long vertical travel where ceiling height or other overhead restrictions must be considered. Two "tube sections" connected with belts and pulleys generate smooth telescopic extension. A unique guiding mechanism provides overall stability.

- Ideal for low ceiling height
- Modular compatibility with other HLE units
- Capable of five meters per second velocity
- Compact platform and attractive appearance

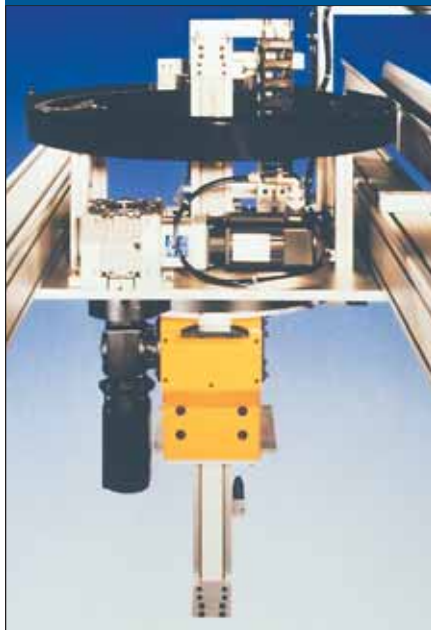

HDM Rotary Modules

The HDM35 is a compact, easily integrated mechanism that adds rotary motion to the vertical axis of a gantry robot. It is designed to mount to the HZR80 and HZR100 vertical units. The HDM35 utilizes a gearbox and motor combination to rotate a vertical drive shaft that passes through the center of the extruded profile.

- 700 degrees of continuous rotation
- Easily integrated
- 360 degrees per second rotation

The HDM409 is a heavy duty rotary mechanism for use with the HZR100 or HTR80 vertical units. The HDM409 supports and rotates the entire Z-axis, thus permitting the full load carrying capability of the vertical axis to be utilized.

- 350 degrees of rotation
- HTR80 and HZR100 compatible
- Heavy duty gear drive mechanism
- Larger payload capability than the HDM35



ET Rod Style Electric Cylinders

Parker's ET rod style actuator is the industry's first packaged electric cylinder. It is ideal as the vertical axis where non-intrusive pick-and-place positioning is required.

- Extra long length rod bearing
- Anti-rotation roller bearing rod support carriage
- Angular contact thrust bearings
- Available in five profile sizes: 32, 50, 80, 100 and 125 mm square
- Six rod end options

Support Structures

Parker can include the support structure and machine guarding as part of your complete system solution. Parker's PAR-Frame™ extruded aluminum structures are suited for light to medium duty requirements. High strength steel supports are offered for applications involving greater loads and forces.

Aluminum Structures

- Lightweight aluminum extrusions
- Economical modular construction
- Standard metric sizes—compatible with Linear Drive units

Steel Support Structures

- Heavy duty support
- High system stiffness
- Ideal for higher overhead gantries
- Engineered and fabricated to customer specifications

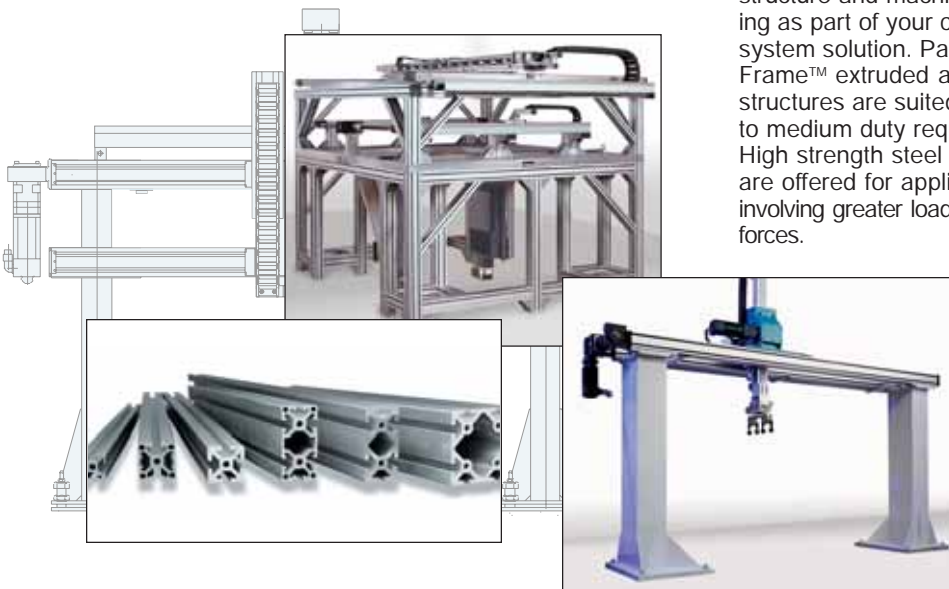

Motors, Drives, and Controls (Electrical Subsystems)

A high speed multi-axis Gantry Robot requires a complete electromechanical solution where the machine Interface, Control and Motor/Drive functions are seamlessly integrated with the mechanical elements.

Parker's wide range of electrical products and sub-systems enable Gantry Robots to be supplied to the customer at the level of integration most suitable for his need. A basic mechanical unit; a unit including drives and motors; or a full blown electromechanical system ready to run or link to a PLC, whatever is needed for your automation requirement, Parker has the best solution.

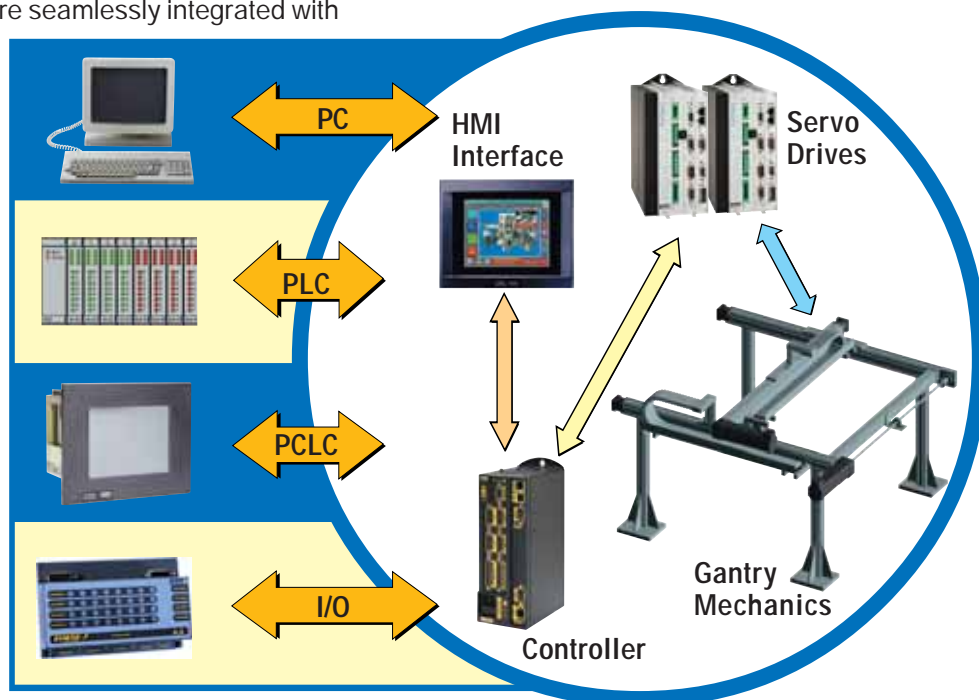

A Bundled HMI Solution with Open Architecture

Parker's CTC division bundles a tightly integrated Human Machine Interface and PC-base Control solution with an open PC hardware platform. A single source that provides affordable integration of factory-hardened PC workstations with the industry's leading HMI and control software. For additional information on Human to Machine Interface and Integrated Machine Control go to www.ctcusa.com

ACR9000 Series Stand Alone Controller

The ACR9000 series of motion controllers combine high-performance and functionality into a stand alone unit. –In addition to standard motion control functions, the ACR9000 offers many additional features including triggered floating point electronic gearing, triggered segmented electronic CAM, on-the-fly position and velocity matching, interruptible moves, analog or digital feedback for position or velocity loops, dual-encoder feedback, data teach and learn functions, plus 3D arcs and splines. The ACR software tools provides further functionality and features.

Compax 3 Servo Drives

With its high-performance and modular design, the Compax3 family of industrial servo drives and drive/controllers offers a new level of servo performance and flexibility. The modular structure of the Compax3 family allows options such as intelligent motion controllers, fieldbus interfaces and industry standard motor feedback. In addition, numerous expansion options can be added to the standard product in order to optimize the capabilities required for today's demanding servo applications.

Brushless Servo Motors

Parker's Compumotor division offers servo drives which feature advanced technologies in motor design: Slotless Stator design, and the Bridged Stator design. These designs provide significant performance advantages to the user. The slotless design eliminates detent torque in the motor, permitting superior performance where smooth, low speed operation is required. The bridged stator design results in very high torque-to-inertia ratios, providing a performance advantage where high accelerations are needed.

Limit and Home Sensors

“End of Travel” Limit Sensors are offered to assure safe operation of the unit by restricting travel to within allowable parameters. This range is dependent upon the load, velocity and acceleration factors determined by the application.

A “Home” Sensor can be positioned to establish a “Machine Start-up” location within the range of travel. Either mechanical or electrical proximity switches can be selected. Limit sensors can be easily positioned along the length of travel to further reduce the allowable operating envelope.

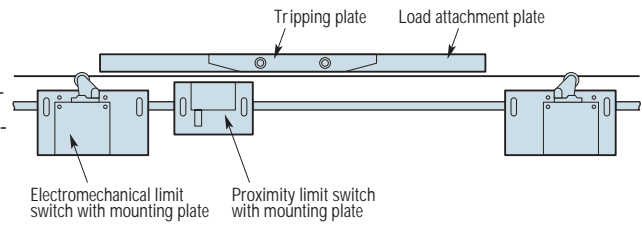

Mechanical Switches

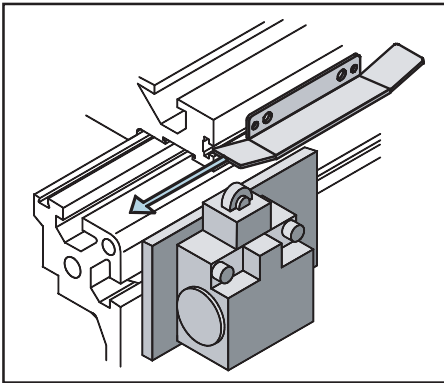

Mechanical Switches for HPLA080, HPLA120, HPLA180, HLE100c and HLE150c

Mechanical switches are triggered by the standard tripping plate. These switches provide one NC and one NO contact per switch.

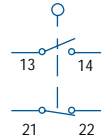

510-900500 for HLE100c; 510-900505 for HLE150c;
002-2442-01 for HPLA 080, HPLA120, HPLA180

Contact Rating	200 V, 6A
Mechanical Lifespan	1,000,000 operations
Operating Temperature	-25½C to 40½C (-13½F to 104½F)
Protection Class	IP65
Terminal Capacity	0,25 mm ² (24 AWG)

Electrical Proximity Switches

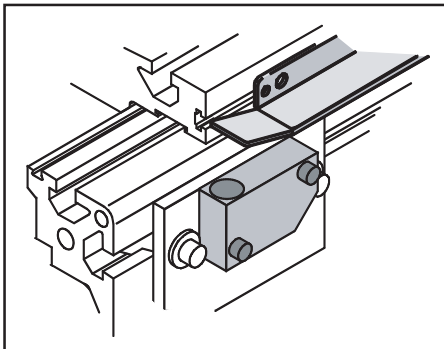

Proximity Switches for HPLA080, HPLA120, HPLA180, HLE60c, HLE100c, and HLE150c

Inductive proximity switches are triggered by a standard tripping plate mounted to the side of the carriage. Available in both NPN and PNP 4-wire DC complementary outputs, the switches can be wired either NO or NC operation.

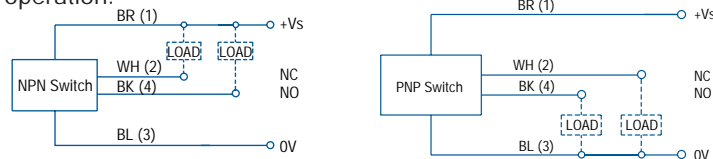

- 002-1892-01 for HLE60RB and HLE60SR
4-wire NPN switch with mounting hardware
- 002-1892-02 for HLE60RB and HLE60SR
4-wire PNP switch with mounting hardware
- 510-900010 for HLE100c
4-wire NPN switch with mounting hardware
- 510-900020 for HLE100c
4-wire PNP switch with mounting hardware
- 510-900030 for HLE150c
4-wire NPN switch with mounting hardware
- 510-900040 for HLE150c
4-wire PNP switch with mounting hardware
- 002-2440-03 for HPLA080, HPLA120, and HPLA 180
4-wire NPN switch with mounting hardware
- 002-2440-01 for HPLA080, HPLA120, and HPLA 180
4-wire PNP switch with mounting hardware

Sensing Distance	4 mm ± 10%
Voltage Supply	10-30 VDC
Switching Capacity	200 mA
Switching Response	2000 Hz
Current Consumption	<200 mA
Voltage Drop	<3 V
Protection Class	IP67
Operating Temperature	-25½C to 70½C (-13½F to 158½F)
Lead Termination	5 meter (200 in)
Reverse Polarity Protection	Yes
Short Circuit Protection	Yes

Belt Driven Modules

Cable Carriers

A cable carrier assembly is normally needed to transport cables to the carriage or custom payload. A complete cable carrier assembly includes the carrier, trough, end brackets, and mounting hardware. The cable carrier should be specifically matched to the linear actuator and other application requirements. Because of the extreme amount of cable flexing associated with high speed cable management, Parker uses only long life "Hi-Flex" cables with its gantry systems. We recommend that all electric cables be approved for high speed cable carrier usage and that manufacturer's guidelines for bend radii are followed.

Cable Carrier Guidelines:

Hose lines should be highly flexible and should only extend slightly under pressure. Weight should be distributed across the cable track as evenly as possible. Cables must not be twisted when routed in the cable carrier and should be routed next to one another with approxi-

mately 10% additional space.

Avoid laying several lines on top of each other and laying lines of different diameters directly next to one another. If multiple layers must be used, dividers should be inserted between each layer – should such circumstances arise, please contact a Parker application engineer.

If there is no alternative to routing several lines beside each other without subdivisions, the clearance height within the carrier must be less than line diameter. This is the only way of preventing the cables from twisting.

The supply cables must be able to move freely in the cable carrier – they must never be fastened or bundled together. Separating strips must always be inserted between flat cables routed in multiple layers.

Due to diversity of the requirements associated with high speed cable management systems, it is recommended that you contact your Parker applications engineer.

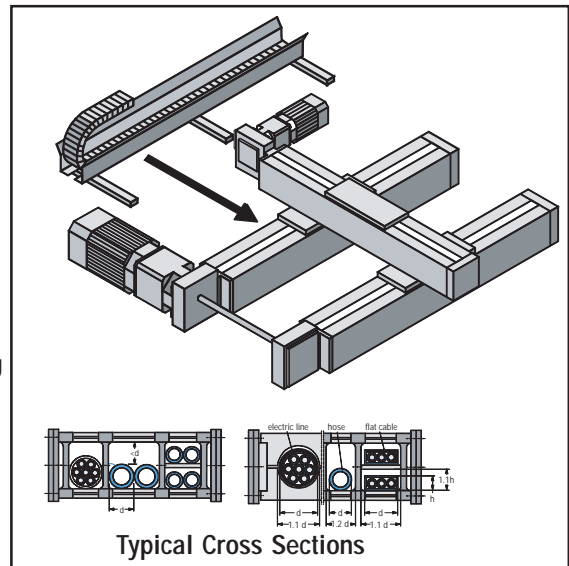

Typical Cross Sections

Junction Box

For systems utilizing cable carriers, Parker recommends and is able to provide junction boxes and high-flex cables for limit switch assemblies. The junction box and cable consolidate the wiring through the cable carriers and provide a "clean" solution for routing limit switch wires to the motion controller.

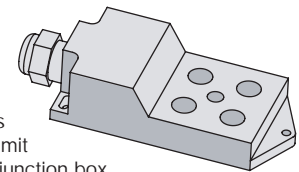

External Bumpers

External bumpers serve as adjustable hard stops. They are fitted to the grooves in the housing profile and are often utilized for restricting total travel.

HLE Series

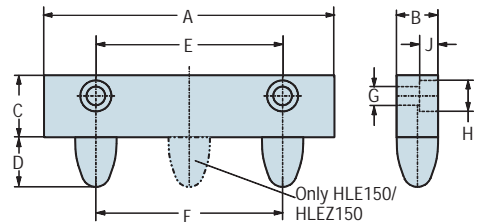
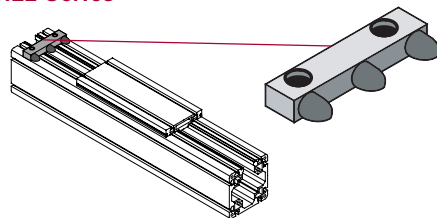

Part No.	Used With		A	B	C	D	E	F	G	H	J
512-300004	HLE100-RB,SR	mm	90	20	30	24	60	40	6.6	11	6.8
512-300005	HLE150-RB, Z		140	20	30	24	90	90	6.6	11	9.0

HPLA Series

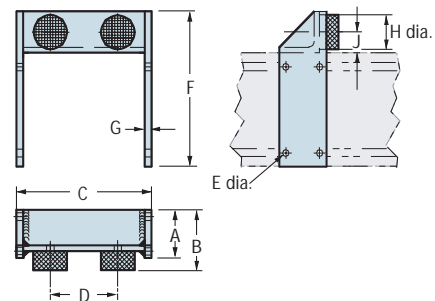
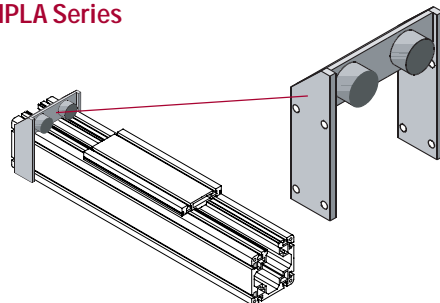

Part No.	Used With		A	B	C	D	E	F	G	H	J
510-006497	HPLA080	mm	30	45	90	56	5.5	91	5	15	11
510-007497	HPLA120		50	60	140	74	9	150	10	30	17
510-008497	HPLA150		70	88	200	100	11	225	10	50	30

Toe Clamps

The toe clamps are used to rapidly install and fasten various combinations of linear actuators to each other; to a PARFrame structure; or to a mounting surface. Two clamps are required to fasten an HLE, HPLA, or HLEZ to a load attachment plate. The table at right shows the profiles for the various axis combinations.

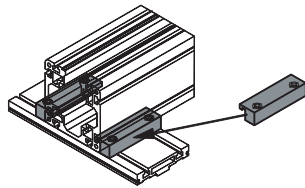
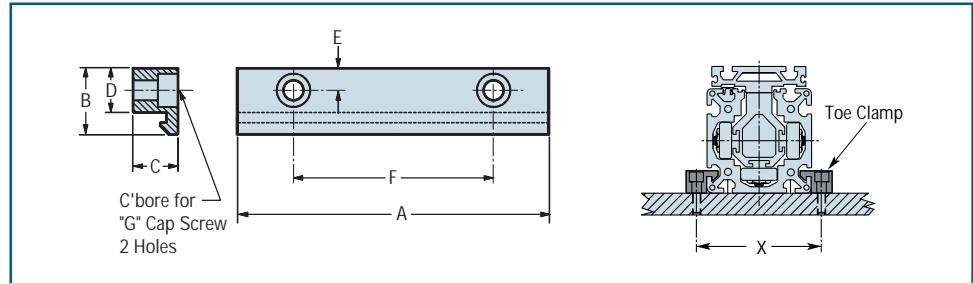

Part No.	Used With	millimeters	A	B	C	D	E	F	G	X
000-7752-01	HLE60-RB (SR)		54	18	10	12	6	43	M5	70
500-000901	HLE100-RB (SR)		90	30	20	20	10	60	M6	120
500-000902	HLE150-RB (Z)		140	40	30	25	12	90	M8	176
500-000925	HPLA120		110	37.5	26	25	12.5	70	M8	145
500-000920	HPLA180		170	45	36	30	15	110	M10	210
500-000930	HPLA080		110	27	17	20	10	70	M8	100
500-000931	HPLA080		76	27	17	20	10	48	M5	100
500-000932	HPLA080		90	27	17	20	10	60	M8	100

T-Nut and T-Bolts

The T-nuts and bolts are used to fasten any element into the T-slots of the profile and to the upper side of the flange plate.

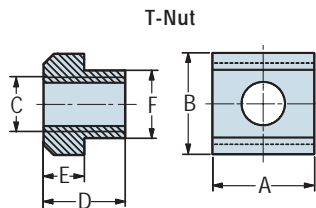

T-Nut

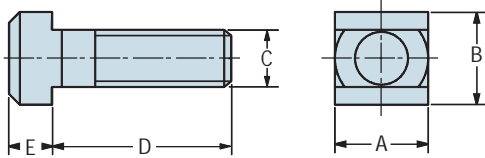

T-Bolt

Standard Part No.	Corrosion Resistant P/N	Used With	A	B	C	D	E	F
100-2353-01	--	HLE60-RB (SR)	11	9	M5	3	--	--
131-700103	135-725400	HLE100-RB (SR)	13	13	M6	10	6	--
131-700104	135-725402	HPLA120, HLE150-RB (Z)	15	15	M8	12	6	10
131-700140	--	HLE100-RB (SR)	26	13	M6	10	6	8
131-700141	135-725406	HPLA120, HLE150-RB (Z)	30	15	M8	12	6	10
131-700135	--	HPLA120, HLE150-RB (Z)	15	15	M6	12	6	10
131-700111	135-725420	HPLA180	35	18	M10	14	7	12
131-700112	135-725401	HPLA180	18	18	M6	14	7	12
131-700102	135-725390	HPLA080	10	10	M5	8	4	5.6
131-700147	--	HPLA080	20	10	M5	8	4	5.6

Standard Part No.	Corrosion Resistant P/N	Used With	A	B	C	D	E
131-700001	--	HLE100-RB (SR)	13	13	M8	25	6
131-700002	135-725450	HLE100-RB (SR)	13	13	M8	32	6
131-700008	135-725460	HLE150-RB (Z), HPLA-120	15	15	M10	32	6
131-700009	135-725465	HLE150-RB (Z)	15	15	M10	40	6
131-700007	135-725459	HPLA120	15	15	M10	25	6
131-700015	135-725480	HPLA180	18	18	M12	50	7
131-700016	135-725482	HPLA180	18	18	M12	25	7
131-700030	135-725430	HPLA080	10	10	M6	15	4
131-700031	--	HPLA080	10	10	M6	25	4
131-700032	--	HPLA080	10	10	M6	30	4

Splice Plates

Splice Plates enable travels to be extended significantly beyond the standard range which is limited by extrusion length. Design concepts and factory installation expertise combine to produce perfectly spliced units which are easily recreated on site. The splice plate connection is only recommended for units with the carriage in the top or the bottom position.

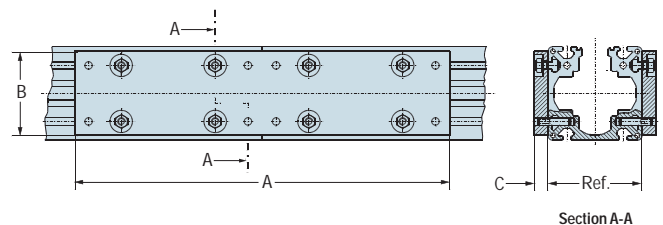
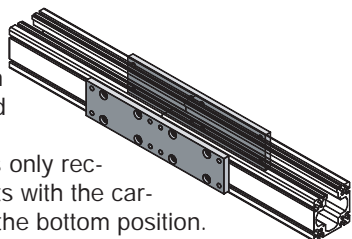

Model/Size	A	B	C	Ref.
HLE100	400	90	15	100
HLE150/HLEZ150	500	130	15	150
HPLA080	300	70	15	80
HPLA120	400	110	15	120
HPLA180	500	165	20	180