

BALL SCREW Assemblies

FROM

LINTECH®

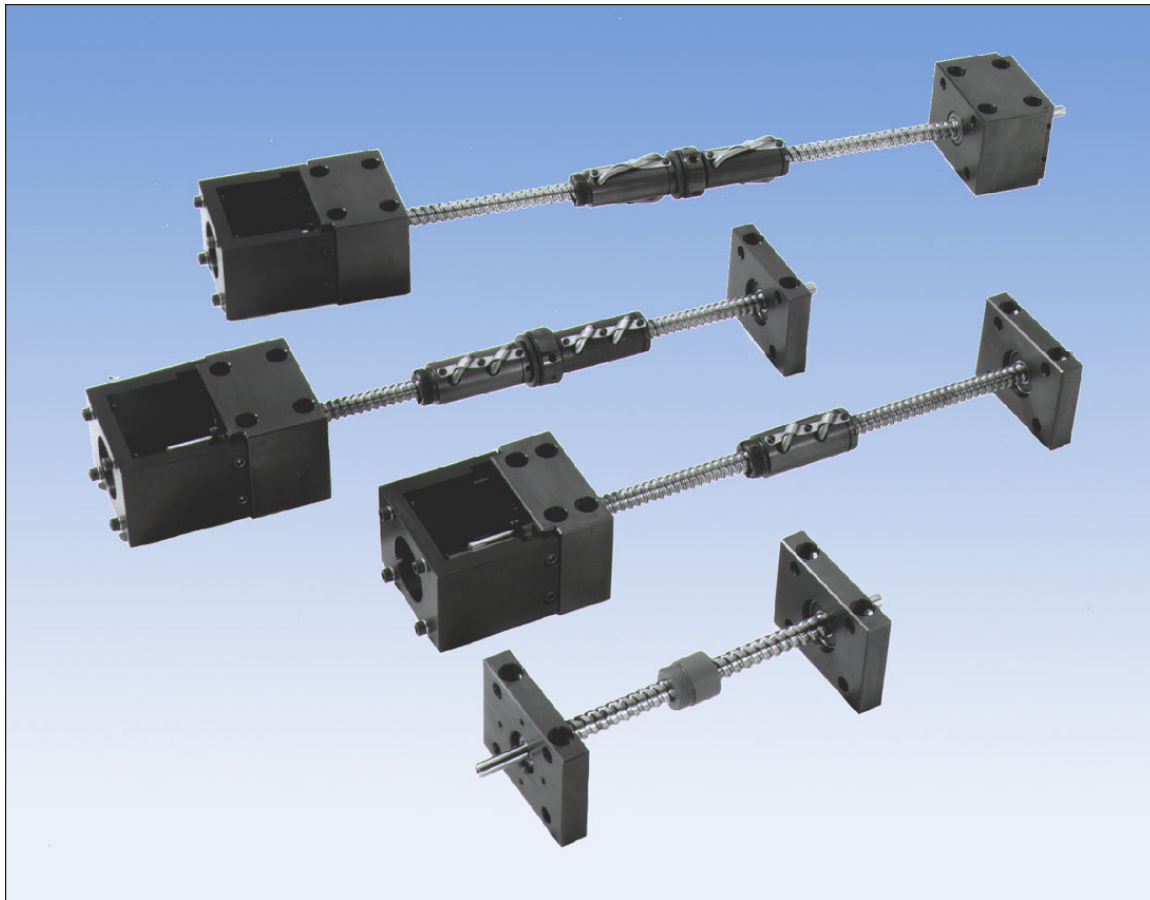

Registered by UL to ISO 9001:2000



Certificate No. A6916

WELCOME to *LINTECH*



For over 35 years *LINTECH* has designed, engineered, and manufactured linear positioning components for use in a wide range of applications. Whether it is a standard positioning component, or a custom positioning assembly, *LINTECH* takes great pride in manufacturing a quality product.

At *LINTECH* we are proud to provide the motion control user with this product guide. It was established to assist you with the design, selection, and implementation of mechanical positioning components.

Depending on the requirements, standard positioning components can often be assembled and shipped in less than 2 weeks. Custom positioning assemblies require a different approach. We evaluate your special application, use our many years of experience to guide you, and then manufacture a quality product designed to meet your performance specifications.

LINTECH's technical support consists of a well trained inside customer service & application engineering staff, a team of experienced design engineers, a modernized CAD system, full functional CNC machines, and a versatile machining facility that is ISO 9001:2000 certified.

Our local technical support group consists of Automation Specialists located throughout the World. These Automation Specialists are experienced in the use of electronic and mechanical motion control products. They are well trained on the performance capabilities of *LINTECH* positioning components.

LINTECH is constantly designing new products and improving upon the many options available with our standard products. Whether it is a standard or custom positioning assembly you need, please write or call us. We look forward to hearing from you.

For the nearest Automation Specialist in your area call:

LINTECH[®]

1845 Enterprise Way
Monrovia, CA. 91016

Toll Free: (800) 435 - 7494
Phone: (626) 358 - 0110
Fax: (626) 303 - 2035

Web Site: www.LintechMotion.com
E-Mail: Lintech@LintechMotion.com

Registered by UL to ISO 9001:2000



Certificate No. A6916



version: 02/2006

TABLE of CONTENTS

	Pages
TECHNICAL REFERENCE	2 - 18
□ Product Comparisons	2 - 4
□ How to Select an Assembly	5 - 8
□ Application Guide	9
□ Screw Travel Life	10
□ Maximum Speed	11
□ Maximum Compression Load	12
□ Motor Sizing	13
□ Part Number Description	14
□ Definitions	15 - 18
INTRODUCTION of RS, PS and GS	19 - 21
□ Introduction	19 - 21
RS Series	22 - 61
□ 0.500 inch Diameter Screws	22 - 29
□ 0.625 inch Diameter Screws	30 - 37
□ 0.750 inch Diameter Screws	38 - 45
□ 1.000 inch Diameter Screws	46 - 53
□ 1.500 inch Diameter Screws	54 - 61
PS Series	62 - 77
□ 0.625 inch & 16 mm Diameter Screws	62 - 69
□ 0.750 inch & 20 mm Diameter Screws	70 - 77
GS Series	78 - 93
□ 0.625 inch & 16 mm Diameter Screws	78 - 85
□ 0.750 inch & 20 mm Diameter Screws	86 - 93
TABLE OPTIONS	94 - 99
□ Motor Couplings	94 - 95
□ Hand Crank, Other Motor Mounts, Wiper Kits, Bellows, and Chrome Plating	96
□ Motor Wrap Packages	97
□ Rotary Incremental Encoders	98
□ Power-off Electric Brakes	99
TERMS of SALE	101

RS Series

- * Rolled Ball Screw
- * Tapped Ball Nut
- * English Leads
- * English Diameters
- * Pre-loaded & Non-preloaded Nuts
- * Simple, Fixed and Rigid Housings
- * Available Sizes
 - 0.500 inch dia., 0.200 inch lead
 - 0.500 inch dia., 0.500 inch lead
 - 0.625 inch dia., 0.200 inch lead
 - 0.625 inch dia., 1.000 inch lead
 - 0.750 inch dia., 0.200 inch lead
 - 0.750 inch dia., 0.500 inch lead
 - 1.000 inch dia., 0.250 inch lead
 - 1.000 inch dia., 0.500 inch lead
 - 1.000 inch dia., 1.000 inch lead
 - 1.500 inch dia., 0.250 inch lead
 - 1.500 inch dia., 0.500 inch lead
 - 1.500 inch dia., 1.000 inch lead
 - 1.500 inch dia., 2.000 inch lead

PS Series

- * Precision Rolled Ball Screw
- * Ground Ball Nut
- * English & Metric Leads
- * English & Metric Diameters
- * Pre-loaded & Non-preloaded Nuts
- * Simple, Fixed and Rigid Housings
- * Available Sizes
 - 0.625 inch dia., 0.200 inch lead
 - 0.750 inch dia., 0.200 inch lead
 - 16 mm diameter, 5 mm lead
 - 16 mm diameter, 10 mm lead
 - 16 mm diameter, 16 mm lead
 - 20 mm diameter, 5 mm lead
 - 20 mm diameter, 20 mm lead

GS Series

- * Precision Ground Ball Screw
- * Ground Ball Nut
- * English & Metric Leads
- * English & Metric Diameters
- * Pre-loaded Nuts Only
- * Simple, Fixed and Rigid Housings
- * Available Sizes
 - 0.625 inch dia., 0.200 inch lead
 - 0.750 inch dia., 0.200 inch lead
 - 16 mm diameter, 5 mm lead
 - 16 mm diameter, 16 mm lead
 - 20 mm diameter, 5 mm lead
 - 20 mm diameter, 20 mm lead

Ball Screw Series	Bidirectional Repeatability Preloaded Nut inches (mm)	Backlash Non-preloaded Nut inches (mm)	Lead Error inch/ft (mm/300 mm)	Maximum Travel Length inches (mm)	Turcite Nut Option	Smoothness with Ball Nut	Audible Noise	Screw Cost
RS Series 0.500 - 0.750 inch diameters	+/- 0.0002 (0,0050)	< 0.008 (0,203)	< 0.003 (0,075)	67 (1702)	Yes	Good	Loudest	Lowest
RS Series 1.000 inch diameters	+/- 0.0002 (0,0050)	< 0.009 (0,229)	< 0.009 (0,229)	137 (3480)	Yes	Good	Loudest	Medium
RS Series 1.500 inch diameters	+/- 0.0002 (0,0050)	< 0.013 (0,330)	< 0.009 (0,229)	134 (3404)	No	Good	Loudest	Medium
PS Series 0.625 inch & 16 mm diameters	+/- 0.0002 (0,0050)	< 0.003 (0,075)	< 0.002 (0,050)	73 (1854)	No	Very Good	Quiet	Low
PS Series 0.750 inch & 20 mm diameters	+/- 0.0002 (0,0050)	< 0.003 (0,075)	< 0.002 (0,050)	112 (2845)	No	Very Good	Quiet	Low
GS Series 0.625 inch & 16 mm diameters	+/- 0.0001 (0,0025)	No option for Non-preloaded Nut	< 0.0005 (0,012)	40 (1016)	No	The Best	Quietest	High
GS Series 0.750 inch & 20 mm diameters	+/- 0.0001 (0,0025)	No option for Non-preloaded Nut	< 0.0005 (0,012)	59 (1499)	No	The Best	Quietest	High

Specifications subject to change without notice

Ball screws are the lead screw of choice for high duty cycle, high speed, and long life applications. The ball screw nut uses one or more circuits of recirculating steel balls which roll between the nut and ball screw threads (grooves), providing an efficient low friction system. Using a higher lead ball screw (a 0.500 inch lead instead of a 0.200 inch lead) will offer greater carriage speed for applications requiring rapid traverse or fast, short incremental moves. Low wear and long life are key features of a ball screw system.

Ball screws from *LINTECH* are available in three different versions. The rolled ball screw system (RS series) utilizes a tapped nut with a standard accuracy rolled ball screw thread. The precision ball screw system (PS series) utilizes a ground nut with a higher accuracy rolled ball screw thread. The ground ball screw system (GS series) utilizes a ground nut with a high accuracy ground ball screw thread.

A ground ball screw will offer better open loop (no encoder feedback) position accuracy versus a rolled or precision rolled ball screw. Some of the screws are available with preloaded nuts. The preloaded nut assembly offers high *bidirectional* repeatability by eliminating backlash.

The Turcite nut option is only available on the RS series and it operates similar to an acme screw. The Turcite nut grooves ride in the matching ball screw grooves, much like the ordinary nut and bolt system. This produces a higher friction system than a ball screw, since there are no rolling elements between the Turcite nut and the ball screw threads. For applications requiring low speeds, low audible noise, very good smoothness, and have a low duty cycle, the Turcite nut works fine. Also, in vertical applications with light loads, the Turcite nut may prevent the back driving of the attached load.

Consideration	Turcite Nut	Ball Screw Nut			Comments
		Rolled (RS)	Precision (PS)	Ground (GS)	
Audible noise	least audible noise	most audible noise	less audible noise than the RS series	less audible noise than the PS series	Turcite: no rolling elements provide for quiet operation. Ball: recirculating balls in nut assembly transmit audible noise during motion; due to more accurate machining procedures - precision & ground ball screws are quieter than rolled ball screws.
Back Driving Loads	may prevent back driving	can easily back drive a load	can easily back drive a load	can easily back drive a load	Turcite: good for light load, vertical applications. Ball: recirculating balls in nut assembly produce a low friction system; vertical applications may require a brake to hold the load when no power is applied to the motor.
Backlash non-preloaded nut	will increase with wear	constant	constant	constant	Turcite: no preloaded nut assembly available. Ball: preloaded nut assembly eliminates backlash.
Duty Cycle	low to medium (< 50 %)	high (100 %)	high (100 %)	high (100 %)	Turcite: low duty cycle due to high sliding friction. Ball: high duty cycle due to recirculating balls in nut assembly - high efficiency & low friction system.
Life	shorter due to higher friction	longest	longest	longest	Turcite: mechanical wear related to duty cycle, load & speed. Ball: minimal wear if operated in proper environment, within load specifications, and periodically lubricated.
Relative - Cost	least expensive	least expensive ball nut	slightly more than RS series	most expensive	Turcite: inexpensive nut. Ball: due to more accurate manufacturing procedures precision rolled & ground ball screws are more expensive.
Screw Efficiency	medium (60 %)	high (90 %)	high (90 %)	high (90 %)	Turcite: low efficiency due to higher sliding friction. Ball: high efficiency due to recirculating balls in nut assembly - low friction system.
Smoothness	smoothest	least smooth	medium smoothness	smoothest	Turcite: very smooth at very low speeds. Ball: smoothness is constant through a wide speed range; due to more accurate manufacturing procedures precision rolled & ground ball screws are smoother than rolled ball screws.
Speeds	low	high	high	high	Turcite: high friction can causes excess heat & wear at high speeds. Ball: recirculating balls in nut provide for a high speed system due to low friction & high efficiency.

Simple Support Housing

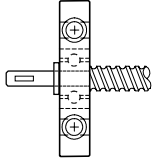

- * All Steel Construction
- * Black Oxide Finish
- * 1 Sealed Radial Bearing
- * No Lubrication Required
- * Base or Face Mounted

Fixed (LT) Support Housing

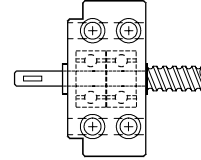

- * All Steel Construction
- * Black Oxide Finish
- * 2 Back to Back Sealed Radial Bearings
- * No Lubrication Required
- * Lip Seals
- * Base or Face Mounted
- * Motor Mount Options

Fixed (HT) Support Housing

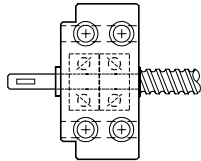

- * All Steel Construction
- * Black Oxide Finish
- * 2 Back to Back Angular Contact Bearings
- * No Lubrication Required
- * Lip Seals
- * Base or Face Mounted
- * Motor Mount Options

Rigid Support Housing

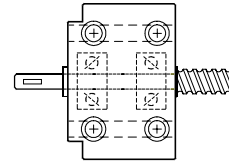

- * All Steel Construction
- * Black Oxide Finish
- * 2 Spaced Apart Angular Contact Bearings
- * No Lubrication Required
- * Lip Seals
- * Base or Face Mounted
- * Motor Mount Options

Possible Configurations	Maximum Speed (rpm)	Thrust Load	Compression Load versus Screw Length	Breakaway Torque	Screw End Play (Backlash)	Support Housing Cost
Simple-Simple	Low	Low	Low	Lowest	Some	Lowest
Fixed(LT)-Simple	Low	Medium	Low	Low	None	Low
Fixed(HT)-Simple	Low	High	Low	Medium	None	Medium
Rigid-Simple	Medium	High	Medium	Medium	None	High
Rigid-Rigid	High	High	High	Highest	None	Highest

Overview

LINTECH's ball screw assemblies can be used in a wide variety of Motion Control applications. Proper selection of an assembly will yield a system that meets the performance requirements with trouble free long term operation. The following steps should be used as a guide to aid in the selection process.

- Step 1** - Initial system requirements
- Step 2** - Determine the desired travel life
- Step 3** - Determine the effect of the load
- Step 4** - Determine the maximum safe speed
- Step 5** - Determine the safe compression load
- Step 6** - Check the Support Configuration
- Step 7** - Applying safety factors
- Step 8** - Review other issues

Step 1 - Initial System Requirements

Several important items should be identified initially. They are: plane of operation, total load weight, system maximum speed, desired travel length, and system repeatability. Answers to these items are required as we move onto the next steps.

Example #1:

- Plane of Operation = Vertical
- Load Weight = 200 lbs plus (+)
 - * 100 pound force required to drill through a material the last 3 inches of a 32 inch downward move
- System Speed = 5 inches / second
- Travel Length = 32 inches
 - * 29 inches of travel is required for part loading
- System Repeatability = 0.001 inches (bidirectional)

Step 2 - Determine the Desired Travel Life

Life consists of the number of inches traveled by the ball screw nut versus the applied load. A simple calculation for required ball screw life is the starting point to aid in selecting the correct ball screw assembly.

Example #1 Continued:

assembly needs to last 6 years
with
a 32 inch move down, then up 32 inches every 90 seconds
for
9 hours per day
for
5 days per week
and
50 weeks per year

$$\frac{(32 \times 2) \text{ inches}}{90 \text{ sec}} \times \frac{60 \text{ sec}}{1 \text{ min}} \times \frac{60 \text{ min}}{1 \text{ hr}} \times \frac{9 \text{ hr}}{1 \text{ day}} \times \frac{5 \text{ days}}{1 \text{ week}} \times \frac{50 \text{ weeks}}{1 \text{ yr}} \times 6 \text{ years} = \mathbf{34,600,000} \text{ inches of travel}$$

Step 3 - Determine the Effect of the Load

Will the ball screw assembly be mounted in a horizontal or vertical plane? We need to determine the load as seen by the "ball screw nut" and as seen by the "support housings". In a horizontal application, the screw and support housing only see the load times the coefficient of friction for the linear bearing structure. Coefficient of friction for various linear bearing surfaces differ, however for recirculating ball bearing style a 0.01 value can be used. In a vertical application, the ball screw nut and the support housing see the entire load as an axial force. Whenever possible, it is best to set-up the ball screw assembly in "Tension Loading" versus "Compression Loading" for vertical applications. This can be done by mounting the "Fixed" or "Rigid" motor mount housing above the screw.

Example #1 Continued:

Vertical Application

Operating Load (as seen by lead screw)	=	Load Weight
	=	200 lbs for 29 inches 300 lbs for 3 inches

We decide to be on the safe side. So we anticipate the entire 300 pounds is seen by the nut all the time and we want a safety margin of 2 times. Therefore we look for a screw that can handle 600 pounds for 34.6 million inches of travel (from step 2).

Example #1 Continued (from page 10):

From the graph we determine the RS075020 suites our needs as it has a life of 40 million inches of travel with a load of 600 pounds.

Step 4 - Determine the Maximum Safe Speed

This is a mechanical limitation defined as the top speed which, if exceeded, has the potential to cause excessive vibration, and damage to the screw, or support bearings. Screw charts are provided for all screws in RPM of the screw. To convert to inches/second, multiply by the desired screw lead.

Example #1 Continued:

Maximum linear speed = 5 inches / second
 Selected screw = RS075020

$$\frac{5 \text{ inches}}{\text{sec}} \times \frac{\text{rev}}{.200 \text{ inch}} \times \frac{60 \text{ sec}}{\text{min}} = 1500 \text{ RPM}$$

Example #1 Continued (from pages 38-45):

Maximum travel length = 32 inches
 Selected screw = RS075020
 Repeatability = 0.001 inches
 (use Preloaded nut)
 Nut length = 6.080 inches

32 inches + 6.080 inches = 38 inches

Example #1 Continued (from page 43):

From the maximum speed graph we determine a Fixed-Simple (Simple-Simple) support configuration would give us 1640 screw RPM with 40 inches between support housings. Because we want a safety margin (in case our linear speed requirement goes up) we select a Rigid-Simple configuration which will give us 2410 screw RPM with 40 inches between support housings.

Step 5 - Determine the Safe Compression Load

A compression load tends to compress or buckle a ball screw shaft. If a sufficiently heavy load is applied to a nut with a long ball screw in a horizontal application, the ball screw could buckle. In a vertical application, if a Fixed or Rigid motor driven housing is mounted below the ball screw, the ball screw weight & load weight could buckle the screw. Therefore, in a vertical application, installing the motor driven support housing above the ball screw puts the ball screw assembly in a tension mode.

Example #1 Continued:

In this vertical application, the ball screw assembly will have the motor driven Rigid support housing mounted above the screw. This puts the ball screw assembly in a Tension mode. Therefore, we do not need to be concerned about a safe Compression load.

Step 6 - Check the Support Configuration

Every support housing on a ball screw assembly has a life based upon the thrust load applied versus the number of screw revolutions. Typically, the motor driven support housing will experience most of the thrust load exerted in a ball screw assembly. First calculate the torques required to move the load, and then calculate the forces exerted on the support housing.

Example #1 Continued (from page 13):

Acceleration Torque = 250 oz-in
 Constant Speed Torque = 230 oz-in
 Deceleration Torque = 175 oz-in

Using the worst case scenario:

$$C_T = \frac{2 \pi e (T_{\text{Total}})}{d} \frac{\text{lb}}{(16 \text{ oz})} \text{ lbs}$$

$$C_T = \frac{2 \pi .90 (250)}{.200} \frac{\text{lb}}{(16 \text{ oz})} \text{ lbs}$$

$$C_T = 442 \text{ lbs}$$

Example #1 Continued (from page 41):

At 442 pounds of thrust load the Rigid support housing has 350 million screw revolutions or 70 million inches of travel life. Our 2 times safety margin is still in effect.

$$\frac{350,000,000 \text{ revs}}{\text{rev}} \times \frac{.200 \text{ inch}}{\text{rev}} = 70,000,000 \text{ inches of travel}$$

Step 7 - Applying Safety Factors

The steel balls of a ball screw nut, or the materials of a Turcite nut, are always subject to repeated stresses in a ball screw application. A key element in the selection process is to determine an adequate safety margin for load/life of a ball screw and support housings.

Static Loads

These loads can exert an extreme force upon the screw & nut in a non-moving state. If a static load rating of a particular ball screw assembly is exceeded, a localized permanent deflection between the recirculating steel balls of a ball nut and the screw, could cause the system to not operate smoothly, or fail outright. To ensure proper life, external forces should never come close to the static rating. Repeated forces at or near the maximum rating can fatigue the elements causing premature failure.

Some static forces will be known and can be accounted for (i.e. drilling, insertion, stamping, engraving, etc.). Other unexpected forces that are difficult to determine could come from vibrations, impacts, or inertial forces. Thus, a safety factor should be considered to account for these forces. This factor represents the ratio of the components load capability versus the applied load.

Operation Conditions	Loading Type	Min. Safety Factor
Stationary	No applied impact or vibration loads.	1.0 - 2.0
	High impact, vibration or thrust loads are present.	2.0 - 6.0

Dynamic Loads

These loads exert a force upon the screw & nut while the screw is in motion. If the rated load of a particular ball screw assembly is exceeded, there is a resultant reduction in the overall travel life. Safety factors are important for these ratings as well. They can help to account for vibration, impact, backdriving, and starting/stopping loads which can reduce the overall life.

As a ball screw driven system moves, there are usually resultant vibrations & impact loads as a by-product. The rate at which the ball screw nut begins to move a load, can have a large impact on the life of a ball screw assembly. The nut sees this start/stop rate as a shock load each time. These and other variable loads cannot be calculated precisely. Thus, a safety factor should be applied to account for these loads which could fatigue the system into premature failure. A safety margin also helps to compensate for changing loads, changing speeds, changing acceleration rates, and lack of lubrication.

Impacts or Vibration	Speed (in/sec)	Acceleration (G's)	Min. Safety Factor
None	< 5	< 0.25	1.0 - 2.0
Small	5.0 - 9.9	0.25 - 0.49	2.0 - 3.0
Medium	10.0 - 20.0	0.50 - 0.99	3.0 - 4.0
Large	> 20	> 1	4.0 - 8.0

Step 8 - Review Other Issues

Audible Noise

As the steel balls of a ball nut circulate through the nut, audible noise is created. The level of this audible noise is determined by the ball screw type, nut design, screw lead, screw rotational speed, coupling style, and motor type used to rotate the screw. Generally speaking, a GS series operates quieter than a PS series, and a PS series operates quieter than a RS series. Because there are no rolling elements in a Turcite nut, this nut option can operate very quietly.

Couplings

The coupling selected can have a major influence on the overall performance of a ball screw assembly. Couplings have a price versus performance relationship. Generally speaking, the C type coupling works fine for stepper driven applications with speeds below 3 inches per second & acceleration rates below .5 g's. The H type coupling works fine for all stepper driven applications, and also works with servo driven applications with speeds below 20 inches per second and acceleration rates below 1 g. The G type coupling will work fine in all applications. Also, for vertical applications, a H type or G type coupling should be used to minimize windup.

Duty Cycle

Duty cycle consists of distance of movement, speed, acceleration rate, and dwell time between moves. In high duty cycle applications, the use of a ball nut is typically a better choice than a Turcite nut. Frequency of lubrication can also become a factor in the overall life of a ball screw assembly in a high duty cycle application. Regularly scheduled lubrication, or an automatic lubrication system, should be considered.

Maintenance/Service Issues

Regular lubrication of a ball screw for most applications is always required. If regular lubrication is impossible, then using a larger safety margin for selecting a ball screw assembly, or the use of an automatic lubrication system, is recommended. The support housings are sealed and require no lubrication or other maintenance.

Motor Control System

The motor control system selected can have a profound effect on the life of a ball screw assembly. Servo motor systems and their peak torque availability can produce high thrust loads to a ball screw assembly. Having too high an acceleration rate, or slamming a nut against a support housing, can cause large thrust forces. These forces can cause a coupling to break, a nut to be damaged, a ball screw to be bent, or a support housing to be damaged. Care should be taken in selecting the correct motor control system to operate a particular ball screw assembly.

Mounting

The ball screw assembly life, and operation, is highly dependent upon how it is mounted. A ball screw assembly should only see straight axial loads (thrust loads), and never should experience side loads or moment loads. In order to obtain optimum results, the ball screw assembly should be used with a linear bearing system. The linear bearing system therefore supports all the system load forces directly and not the ball screw assembly. The ball screw assembly must also be mounted parallel to the linear rails.

Operational Environment

The environment that a ball screw assembly is used in can greatly influence its life. Bellows, chrome plating, or other special requirements may be needed for high temperature, high humidity/moisture, vacuum rated, clean room, cutting, machining (chip/particulates), cutting fluids or chemical compound applications.

Repeatability versus Accuracy

Repeatability is defined as the ability of a ball screw assembly to go back to a set and known position, over and over again. Accuracy is defined as the ability of a ball screw assembly to move from one location to another and the actual exact distance to get there. Repeatability is noncumulative, while accuracy is cumulative.

Name _____ Date _____

Company _____

Address _____

City _____ State _____ Zip _____

Phone (____) _____ Fax (____) _____

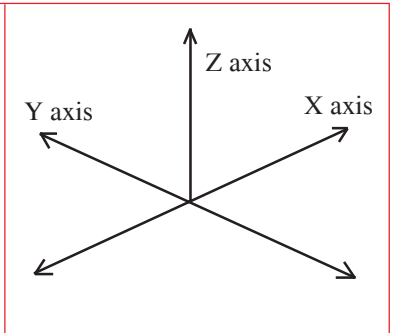

Positioning System Specifications

Axis	X	Y	Z	Axis	X	Y	Z
Ball Screw Type (rolled, precision, ground)				Duty Cycle (%)			
English or Metric (E or M)				Travel Length (L-N) (inches or mm)			
Shock/Impact Loads (none, low, medium, high)				Repeatability (inches or mm)			
Overall Travel Life (millions of inches or Km)				Lead Error (inch/ft or mm/300mm)			
Maximum Accel (inches/sec ² or m/sec ²)				Nut Flange Type (round, vertical, "L")			
Maximum Speed (inches/sec or m/sec)				Motor Frame Size (NEMA 23, 34, 42, other)			
Most Difficult Move Profile	Distance (in or mm)			Encoder (Resolution)			
	Time (sec)			Power-off Brake (Yes or No)			

Special Requirements

- High Temperature Clean Room Maximum Smoothness Motor Wrap
 Vacuum Rated High Moisture Low Audible Noise Other (explain below)

Screw & Support Housing Loads

Load Weight as Seen by the Ball Screw (pounds)

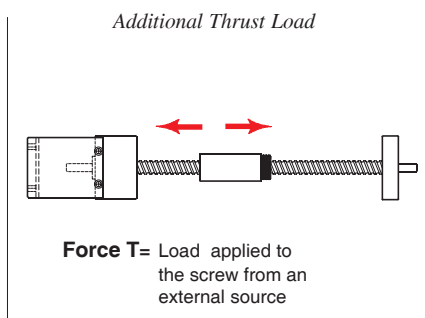
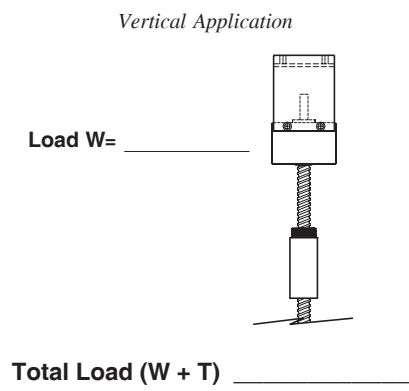
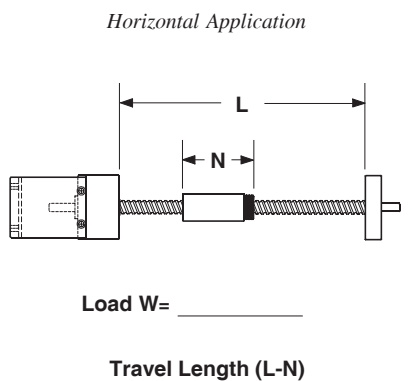

Application Details

(please describe and attach separate sketch if required)

Screw Travel Life

The life of a ball screw is determined by the load applied to the nut, and the number of inches (mm) traveled by the nut. The load weight "as seen by the ball screw" depends upon screw orientation. Any side, or moment, loads that the screw sees, will reduce life. These forces should be eliminated by using a linear bearing system.

$$L = \left[\frac{R}{F} \right]^3 \times B$$

- L** = normal travel life (millions of inches or Km).
- R** = rated dynamic load capacity of nut at 1 million inches of travel or 25 Km.
- F** = user applied axial load.
- B** = either 1 (for millions of inches) or 25 (for Km).

Horizontal Application

$$\text{Applied Axial Load (as seen by lead screw)} = \frac{\text{Load Weight}}{\mu} \times \mu$$

μ = coefficient of friction for linear bearing system (0.01 for typical linear rail & bearing systems)

Vertical Application

$$\text{Applied Axial Load (as seen by lead screw)} = \text{Load Weight}$$

Note: See the individual ball screw sections for exact Screw Travel Life information

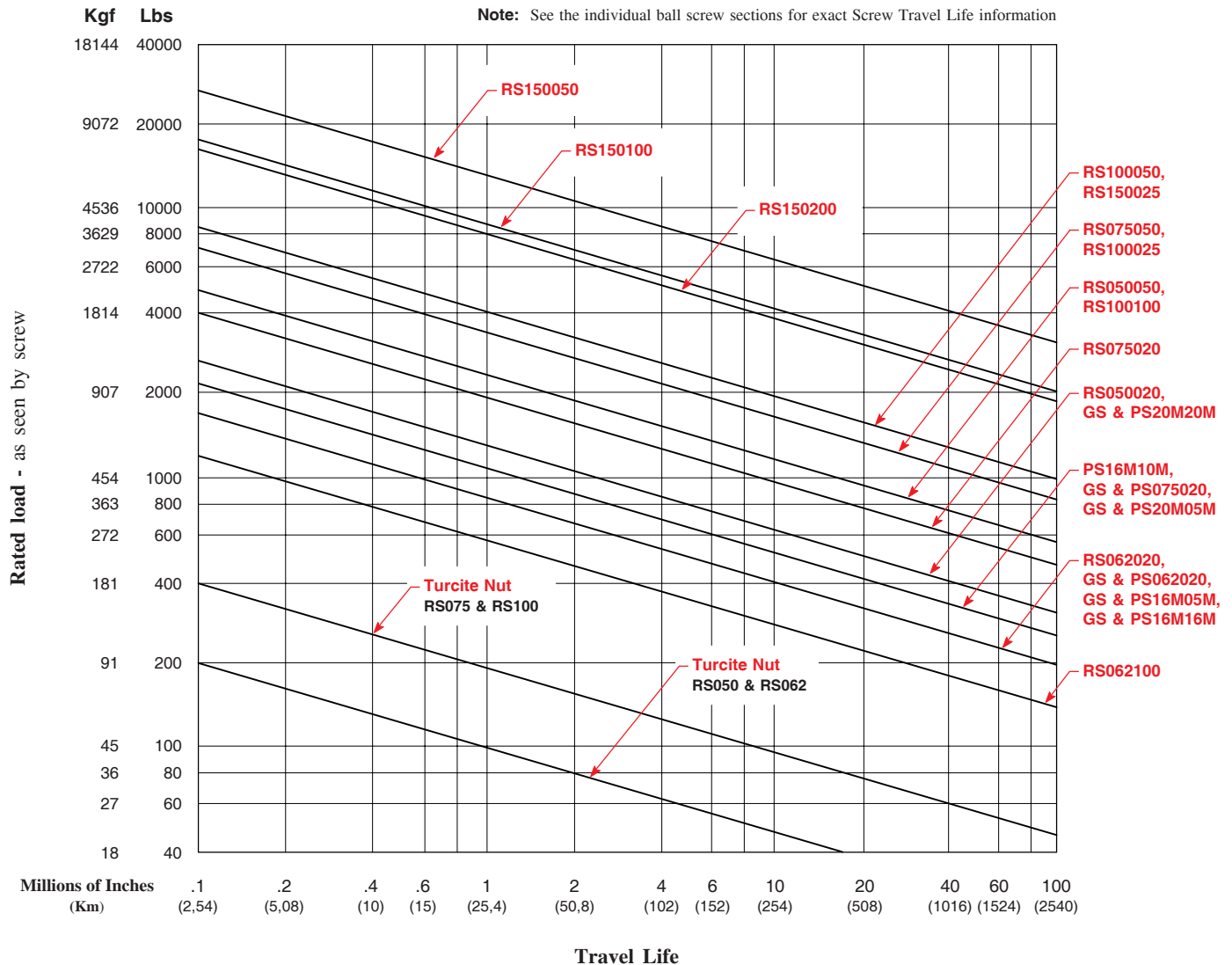

Maximum Speed (Critical Speed)

The maximum rotational speed of a ball screw assembly (RPM's) depends on the diameter of the screw, the length of the screw, and the support housing configuration. This is the point at which the rotational speed of the ball screw sets up excessive vibration within the assembly. The maximum speed should never be exceeded since it could cause immediate, or premature failure of a ball screw assembly.

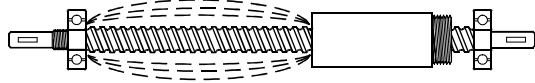

$$MS = S_F \times 3,808,000 \times \frac{d_F}{D^2}$$

- MS** = Maximum screw speed (revolutions per minute).
- S_F** = Screw support factor (rigidity of support housing).
- d_F** = Diameter factor. $d_F = \frac{\text{screw diameter} + \text{root diameter}}{2}$
- D** = Unsupported screw length ("D" distance between bearing supports).

Available Configurations

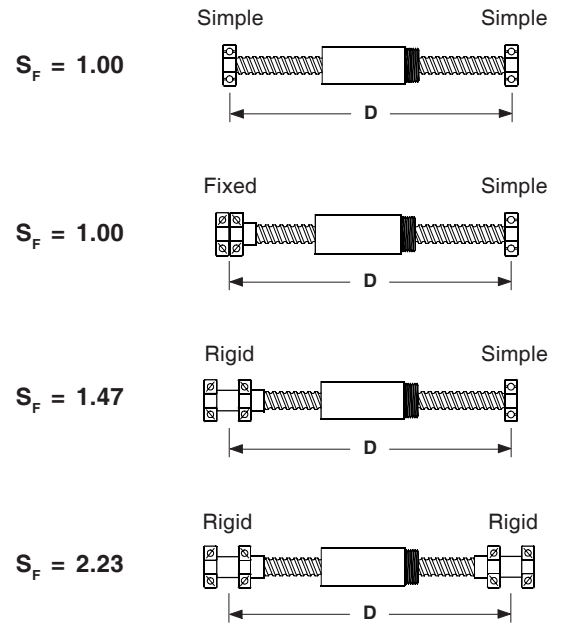

Note: See the individual ball screw sections for exact Maximum Speed information

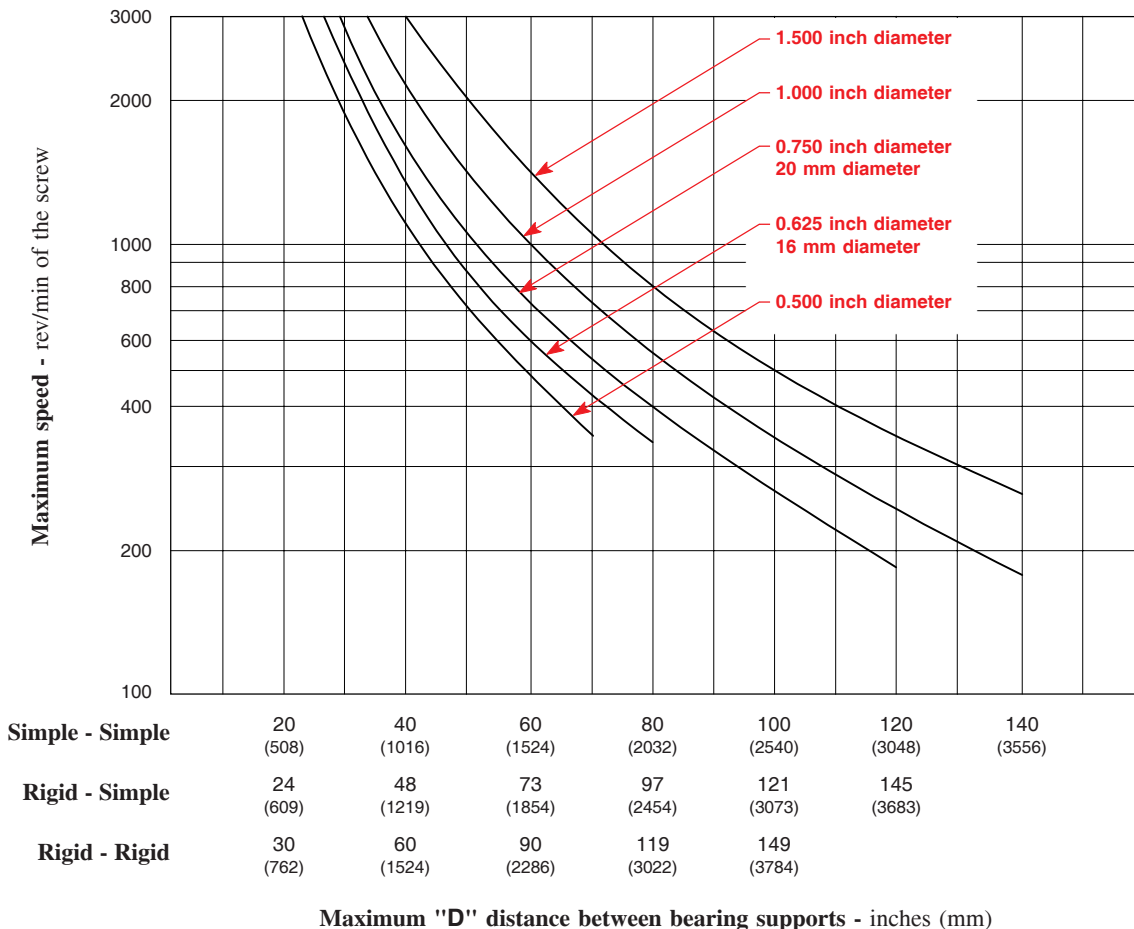

Maximum Compression Load

The load acting upon a nut that would tend to compress or buckle the ball screw shaft. Also referred to as column loading, this rating is effected by the load, support type, screw diameter, and length between the load point and support housing. Normally, a screw shaft also experiences a tension load (a force which attempts to stretch the screw). The maximum tension load of a ball screw assembly is the load rating of the nut. For vertical applications, it is better to configure the ball screw assembly so that the screw is in tension, and not in compression.

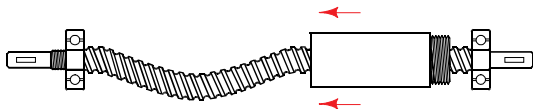

$$MC = C_F \times 11,240,000 \times \frac{d^4}{X^2}$$

- MC** = Maximum Compression Load.
- C_F** = Screw support factor (rigidity of support housing).
- d** = Root diameter.
- X** = Distance between bearing support and load

Available Configurations

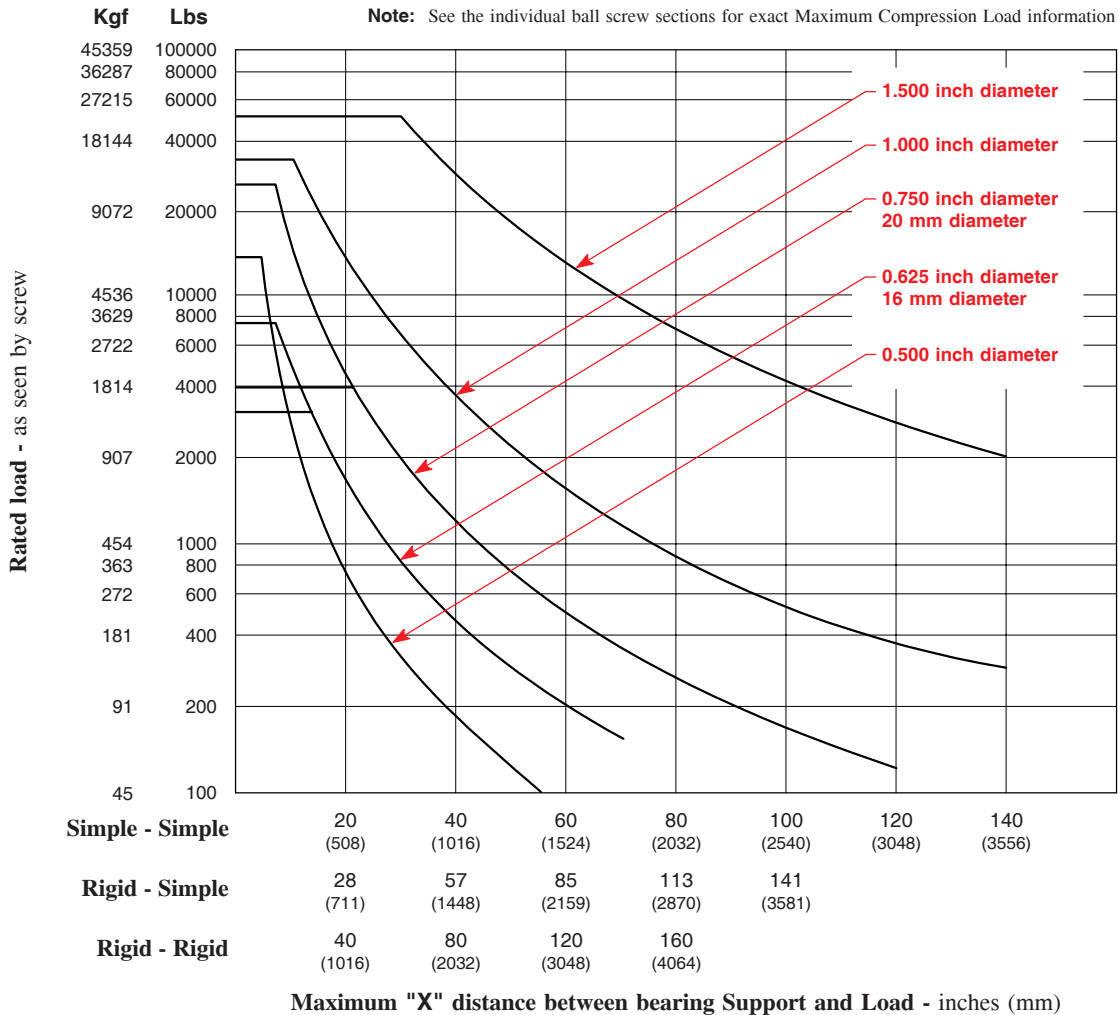
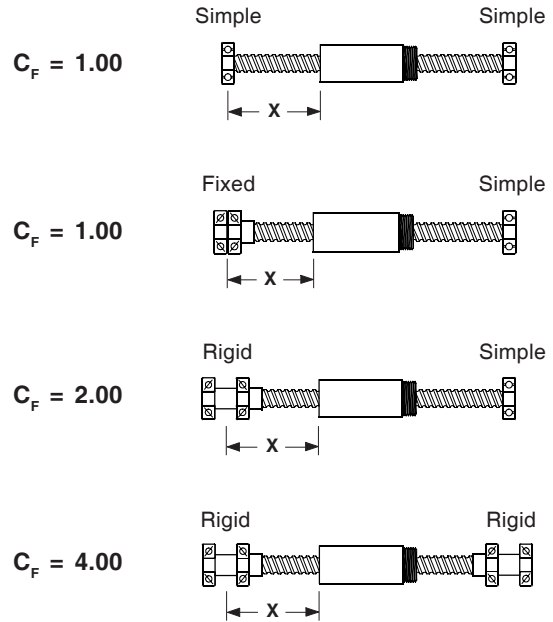

Specifications subject to change without notice

Torque Equations - Lead Screws (Linear Motion)

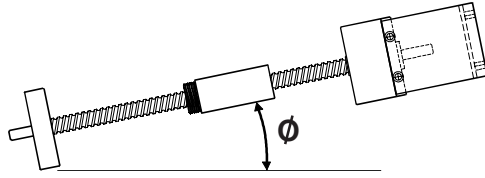

$$T_{\text{Total}} = \left[T_{\text{Acc}} + T_{\text{Breakaway}} + T_{\text{Friction}} + T_{\text{Gravity}} \right] \text{SF} \quad (\text{oz-in})$$

$$T_{\text{Acc}} = \frac{1}{386} \left[\frac{J_{\text{Load}}}{e} + J_{\text{LS}} + J_{\text{Motor}} \right] \frac{\omega}{t_a} \quad (\text{oz-in})$$

$$J_{\text{Load}} = \frac{d^2 (W_{\text{Load}} + W_{\text{Other}})}{(2\pi)^2} \frac{(16 \text{ oz})}{\text{lb}} \quad (\text{oz-in}^2)$$

$$J_{\text{LS}} = \frac{\pi \rho L R^4}{2} \quad (\text{oz-in}^2)$$

$$J_{\text{Motor}} = \text{See Motor Data (not included in this catalog)} \quad (\text{oz-in}^2)$$

$$\omega = \frac{2\pi V_M}{d} \quad (\text{rad/sec})$$

$$T_{\text{Breakaway}} = \text{See values in individual screw technical sections} \quad (\text{oz-in})$$

$$T_{\text{Friction}} = \frac{d F_T \cos \phi}{2\pi e} \frac{(16 \text{ oz})}{\text{lb}} \quad (\text{oz-in})$$

$$F_T = \mu (W_{\text{Load}} + W_{\text{Other}}) \quad (\text{lbs})$$

$$T_{\text{Gravity}} = \frac{d (W_{\text{Load}} + W_{\text{Other}}) \sin \phi}{2\pi e} \frac{(16 \text{ oz})}{\text{lb}} \quad (\text{oz-in})$$

Notes:

1) T_{Total} is the maximum torque required from a motor during a move. This usually occurs during the acceleration portion of a move profile for horizontal applications and an upward move for vertical applications. During the deceleration portion of a move profile, T_{Friction} and $T_{\text{Breakaway}}$ are subtractions from T_{Total} . For horizontal applications T_{Gravity} has a zero value.

2) The factor 386 in the denominator for the T_{Acc} equation represents acceleration due to gravity (386 in/sec^2 or 32.2 ft/sec^2) and converts inertia from units of oz-in^2 to oz-in-sec^2 .

3) The safety factor (SF) should be between 1.4 to 1.6 for step motor systems and between 1.1 to 1.2 for servo motor systems.

Thrust Force Equation

$$C_T = \frac{2\pi e (T_{\text{Total}})}{d} \frac{\text{lb}}{(16 \text{ oz})} \quad (\text{lbs})$$

Terms

C_T	= created thrust force (lbs)
d	= lead of screw (in/rev)
e	= screw efficiency (90% = .9)
F_T	= total frictional force (lbs)
J_{Load}	= load inertia (oz-in ²)
J_{LS}	= lead screw inertia (oz-in ²)
J_{Motor}	= motor inertia (oz-in ²)
L	= lead screw length (in)
ϕ	= angle of load from horizontal (degrees)
ρ	= density of steel screw (4.48 oz/in ³)
R	= radius of lead screw (in)
SF	= safety factor (see note #3)
t_a	= acceleration time (sec)
T_{Acc}	= required torque to accel the load (oz-in)
$T_{\text{Breakaway}}$	= breakaway torque (oz-in)
T_{Friction}	= required torque to overcome system friction (oz-in)
T_{Gravity}	= required torque to overcome gravity (oz-in)
T_{Total}	= required torque to move the load (oz-in)
μ	= coefficient of friction for linear bearing system (.01)
V_M	= max linear velocity (in/sec)
ω	= angular velocity (rad/sec)
W_{Load}	= weight of load (lbs)
W_{Other}	= weight of nut or weight of mounting hardware (lbs)
π	= 3.1416

xS 062 020 - x - Sx - Nx - Wx - Fx - Mxx - Cxxx - Exx - Bxx - Lxxx.xxx

Series - (xS)

There are three different ball screw types available. They are the Rolled Screw (RS), Precision Screw (PS), and the Ground Screw (GS).

Screw Diameter - (062)

These three digits define the diameter of the ball screw. For English screws, the number denotes the diameter in inches (x.xx). For Metric screws, the number denotes the diameter in millimeters (xxM).

Screw Lead - (020)

These three digits define the screw lead. For English screws, the number denotes the lead in inches (x.xx). For Metric screws, the number denotes the lead in millimeters (xxM).

Internal Order Code - (x)

This digit is only required for the ground ball screw series (GS). It denotes if the screw thread length is short (1) or long (2). The appropriate series will give the information that constitutes what is a short or long length.

Support Configurations - (Sx)

Five standard choices are available which define the type of ball screw support housings. They are Simple-Simple (S1), Fixed(LT)-Simple (S2), Fixed(HT)-Simple (S3), Rigid-Simple (S4), and Rigid-Rigid (S5). Each screw series and screw diameter lists the technical data for these support configurations.

Nut Type - (Nx)

Three different nut styles are available for a ball screw assembly. They are a non-preloaded ball nut, a preloaded ball nut, or a non-preloaded Turcite nut. The RS series has all three options available through the 1.000 inch diameter screw. The 1.500 inch diameter RS series and the PS series only have the non-preloaded ball nut and preloaded ball nut options. The GS series only has the preloaded ball nut options. Also, the threads on the ball nut can face to the right of the assembly, or to the left of the assembly with respect to the drive end housing.

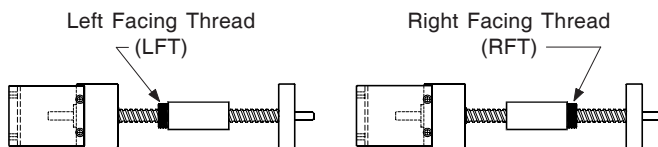

Nut Wipers - (Wx)

This indicates if the brush type wipers on the nut assembly are required (W1). This option is only available for the ball nut versions of the RS series.

Nut Flange Type - (Fx)

There are three available nut flanges. They are a round flange (F1), a vertical bracket (F2 or F3), and a "L" bracket (F4 or F5). If selected, these brackets are premounted to the nut on the ball screw assembly. The vertical bracket and "L" bracket options are available with either an English or Metric interface for mounting of the user load. Since the round flange has thru holes, the user can use either English or Metric nuts & bolts.

Motor Mount - (Mxx)

The Fixed and Rigid housings of each screw series are designed to accept NEMA 23, NEMA 34, or NEMA 42 motor mount brackets with either an English or Metric mounting interface for the user motor. These housings can also accept NEMA 23, NEMA 34, or NEMA 42 motor wrap packages. No Simple housing is designed to accept a motor mount option. Custom motor mount packages are available upon request. There is a Hand Crank option for the smaller diameter screws within each screw series.

Coupling Type - (Cxxx)

Three different styles of motor couplings are available. They are the C type, H type, and G type. Each of these styles have different diameters, lengths, torque ratings, and wind-up values. For a given screw series and screw diameter, only certain sizes within each coupling style is available. This is due to the diameter of the ball screw extension from the drive housing and the available motor mount bracket sizes.

Rotary Encoder - (Exx)

There are three different resolutions for the incremental rotary encoder which can be mounted to the support housing opposite the motor driven housing. They are a 500, 1000, and 1270 line per revolution encoders. These shaftless encoders are first mounted to an adapter plate, and then mounted to either the Simple, Fixed, or Rigid housing.

Power-off Brake - (Bxx)

There are two different input power requirements (24 or 90 VDC) for the power-off brake which can be mounted to the support housing that is opposite the motor driven housing. These shaftless brakes are first mounted to an adapter plate, and then mounted to either the Simple, Fixed, or Rigid housing.

Thread Length - (Lxxx.xxx)

This value specifies the length in inches (xxx.xxx) of the screw thread between the inside edges of the two support housings. Actual nut travel will be this value minus the overall nut length selected for the assembly.

Backlash

Preloaded and non-preloaded ball screw nut assemblies are available for use in the RS and PS series. The GS series is only available with a preloaded nut. A preloaded nut ensures there will be no ball screw movement, without nut movement, when the ball screw direction of rotation is changed. A non-preloaded nut will have some backlash, ball screw movement before nut movement, when the ball screw direction of rotation is changed in horizontal applications. In vertical applications (with no reversing load), a non-preloaded nut will not exhibit any backlash, as gravity is always producing a force in the downward direction against the ball screw nut. *Using a preloaded nut always eliminates backlash, therefore the unidirectional & bidirectional repeatability values will always be the same.*

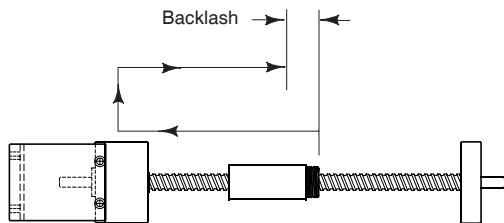

Backdriving

The ability of the ball nut to rotate the ball screw when an external force is applied to the nut. Typically happens in vertical applications where the applied load is great enough to overcome the ball nut's frictional forces.

Ball Diameter

The nominal outer diameter of the steel balls which circulate through the ball nut as it travels on the ball screw threads. These balls carry the load applied to the ball screw through the ball nut.

Base Mounting

Allows mounting of a support housing to a base plate.

Breakaway Torque

The torque required to start linear nut motion. It consists of the bearing support configuration, bearing support end seal friction, preload force of the support housing (if any), and the preload force of the ball screw nut assembly.

Diameter

(Screw diameter or major diameter) The nominal outer diameter of the ball screw thread. Measured in inches for English model screws, and millimeters for Metric model screws.

(Root diameter or minor diameter) The diameter of the screw measured at the bottom of the ball threads on the screw. Measured in inches for English model screws, and millimeters for Metric model screws.

Dynamic Load

The maximum load weight, as seen by the ball nut, which will give the rated life of the ball nut. The rated life of a ball screw assembly is measured in inches of travel under a specified load. Ball nut life is dependent upon preloaded force, load weight and load orientation.

Face Mounting

Allows mounting of a support housing to a wall, end plate, frame, or gusset and does not require a base surface.

Hardness

The property of a material which has the ability to abrade or indent one another. Ball screws are hardened to resist permanent indentation. Typically a Rockwell "C" measurement is used to obtain a numerical value based on a metals resistance to permanent indentation. The higher the value, the greater the materials resistance to indentation.

Lead

For a ball screw, the linear travel of the ball screw nut assembly, for every one full (360 degree) rotation of the screw. Not the same as pitch. Lead is the inverse of pitch (i.e. 0.200 inch lead = 5 pitch).

Lead Error

The error in lead length per foot, or 300 mm, as compared to the basic lead specified. Lead error is cumulative, and is based upon the manufacturing processes of the individual ball screw types.

Lubrication

Ball screw assemblies require a small amount of grease or oil for proper, long term operation. Lubrication will decrease system wear and the potential for oxidation of the ball screw surface. For most applications, a medium to heavy oil, light grease, or silicone based lubricant is recommended. The many built-in pockets within the ball screw nut allow the adhesive properties of these lubricants to be stored for extended periods of time.

For high speed applications, a light grease is recommended, while the ball screw should NEVER be operated dry for any length of time. For some low speed and lightly loaded applications, a ball screw assembly can typically be operated without lubrication, but for the most part, this is not recommended. Use of WD-40, or other cleaning solvents, should strictly be avoided, as they can cause damage to the ball screw nut.

All ball screw assemblies are shipped with grease applied to the ball screw & ball nut. It is recommended that lubricant be applied to the ball screw and linear rails prior to operation. Also, periodic re-lubrication helps assure that the rated life of the ball screw assembly is attained.

All support housings do NOT require lubrication. The housings or bearings are internally lubricated for life, and sealed to prevent outside contamination from getting in.

Maximum Acceleration Rate

This rating is the maximum acceleration that a ball nut or support housing can handle on a regular basis. It is also limited by the maximum thrust force a particular nut or support housing can sustain. For example, if the maximum acceleration for a ball screw assembly is 772 inches/sec², but a specific load accelerated at 100 inches/sec² produces the maximum thrust force for the ball screw or support housing - then the maximum acceleration rate for that load is 100 inches/sec². ($F = MA$).

Maximum Speed

The maximum rotational speed of a ball screw assembly (RPM's) depends on the diameter of the screw, the length of the screw, and the support housing configuration. This is the point at which the rotational speed of the ball screw sets up excessive vibration within the assembly. The maximum speed should never be exceeded since it could cause immediate, or premature failure of a ball screw assembly.

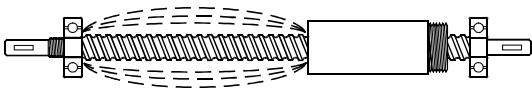

Maximum Compression Load

The load acting upon a nut that would tend to compress or buckle the ball screw shaft. Also referred to as column loading. This rating is effected by the load, support type, screw diameter, and length between the load point and support housing.

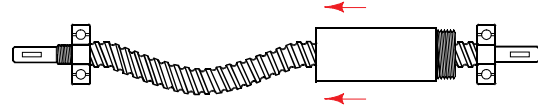

Number of Circuits

The circuit or "return tube" on a ball nut provides for distributing the load carrying balls onto the screw thread as they recirculate through the ball nut. The return tubes can be either external or internal.

Non-preloaded Nut

A single ball nut, or Turcite nut, that produces backlash when the screw is rotated back and forth.

Preloaded Nut

A single, or double, ball nut that eliminates backlash when the screw is rotated back and forth. The preloading can be accomplished internally, or externally. The internal method uses oversized load carrying balls in the nut and also requires that the nut be "matched" to an individual screw. The external method loads two single nuts against each other with a locking spanner nut and belville spring.

Repeatability

How accurate a ball screw's nut can (via either unidirectional or bidirectional moves) return to a known, previously traveled location for a given load weight, load speed, and load acceleration. The ball screw nut type (preloaded or non-preloaded) directly affects this value. Other factors besides the ball screw assembly, that contribute to the overall repeatability are the linear bearing system, mounting surface, and overall alignment of the bearings, rails, and screw assembly.

For horizontal applications, the bidirectional repeatability value is determined by adding the backlash in the lead screw nut assembly to the unidirectional repeatability value. For vertical applications (with no reverse load), the bidirectional and unidirectional repeatability will be the same, as gravity eliminates backlash in non-preloaded nut assemblies. Using a preloaded nut assembly always eliminates backlash. Therefore, the unidirectional & bidirectional repeatability values will always be the same.

Horizontal Applications - Unidirectional Repeatability

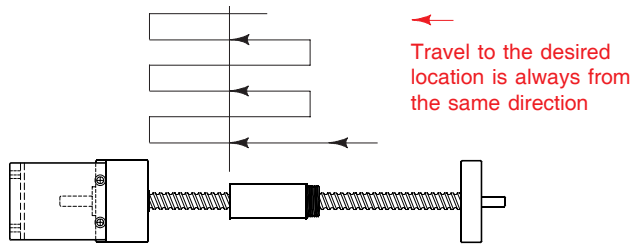

Horizontal Applications - Bidirectional Repeatability

(Unidirectional Repeatability + Backlash)

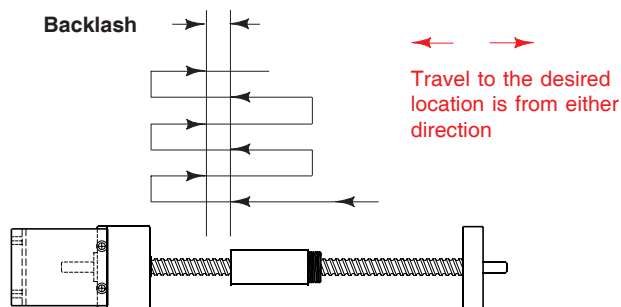

Repeatability - continued

Vertical Applications (No reverse load)

Bidirectional Repeatability = Unidirectional Repeatability

Reverse Load

An upward force acting on a nut; such as when inserting a part (moving in a downward direction) into another part.

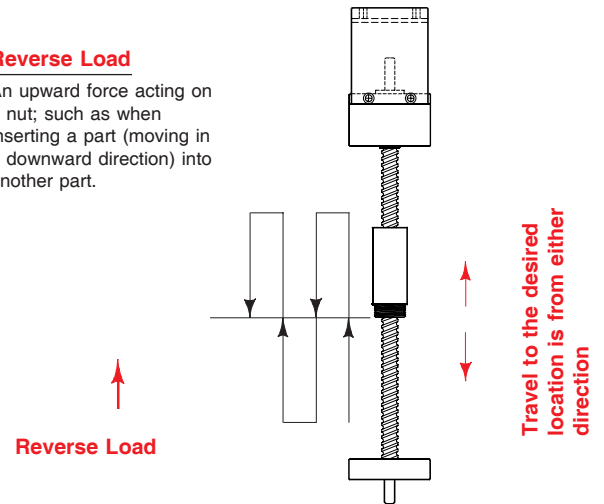

Right Hand Thread

The direction of the threads on the screw, which cause the nut to travel away from the end viewed, when the screw is rotated in a clockwise direction.

Screw Efficiency

This defines the "loss of energy" when attempting to move the ball nut by rotating the ball screw. Used for calculating torques required to move a specified load weight. Ball nuts typically have an efficiency of 90%, while Turcite nuts typically have an efficiency of 60%.

Screw Maximum Length

This is the overall length "end to end" of the screw stock available for each screw series and screw diameter. Does not specify what the maximum travel, or thread length is.

Static Load

The maximum permissible load weight, or external force, which can be applied to the nut of the ball screw assembly, with the ball screw at rest.

Support Housings

Simple - A single bearing used to support the end of a ball screw.

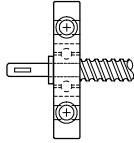

Fixed - Two (2) back to back bearings used to eliminate end play when supporting the end of a ball screw.

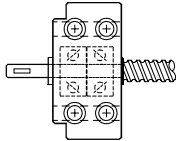

Rigid - Two (2) spaced apart bearings used to eliminate end play and to provide added rigidity when supporting the end of a ball screw.

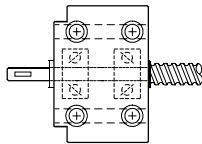

Support Housing Thrust Load Capacity

The maximum permissible axial force which can be applied to the end bearing support housing. The axial force is generated by the movement of the ball screw. The support housing life is dependent upon the number of screw revolutions and axial force applied.

Tension Loading

The load acting upon a nut that would tend to stretch the ball screw shaft. The maximum tension load of a ball screw assembly is the load rating of the nut. For vertical applications, it is better to configure the ball screw assembly so that the screw is in tension and not in compression.

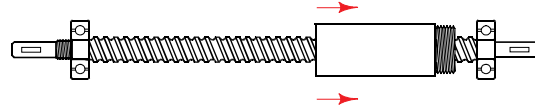

Vertical Applications

Compression

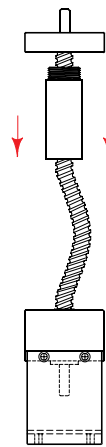

Tension

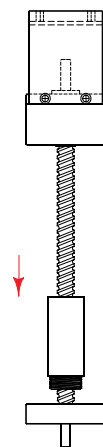

Travel Length

The total possible travel of the nut for a given ball screw configuration. The ball screw assembly thread length minus the nut length will determine the possible nut travel length.

Thread Length

The total length of the screw thread between the two support housings for a given configuration. The ball screw assembly thread length minus the nut length will determine the possible nut travel length.

Turcite Nut

This polymer material has characteristics similar to Teflon. There are no recirculating balls within the nut assembly. It is resistant to corrosion, but has higher friction than a ball nut, thus creating more heat and wear.



Ball Screw Assemblies

LINTECH's ball screw assembly products use precision machined components throughout their construction. Strict manufacturing policies and procedures ensure that every assembly meets, or in most cases, exceeds specifications. Built with exceptional quality, these positioning components offer years of reliability. Due to our unique manufacturing capabilities, LINTECH can usually deliver most ball screw assemblies in less than two weeks. With the many available options, LINTECH can manufacture a ball screw assembly capable of performing in a wide variety of applications.

Ball Screw Assemblies

LINTECH's ball screw assembly positioning components are utilized in a wide variety of Motion Control applications.

- ❑ *Welding*
- ❑ *Test Stands*
- ❑ *Part Insertion*
- ❑ *Laser Positioning*
- ❑ *Liquid Dispensing*
- ❑ *Semiconductor Processing*
- ❑ *Gluing*
- ❑ *Pick & Place*
- ❑ *Part Scanning*
- ❑ *Inspection Stations*
- ❑ *Medical Equipment*
- ❑ *General Automation*

Quality Construction

LINTECH's RS, PS, and GS series are designed to maximize performance, while providing design flexibility. These assemblies utilize a rolled, precision rolled, or ground ball screw with preloaded or non-preloaded nuts. These steel ball screws are provided with precision machined steel supports for end bearing housings. The support housings are available in three styles (simple, fixed, and rigid). The fixed and rigid housings have precision machined shoulders that allow for a NEMA motor mount to be factory or field installed.

Ball screw assemblies when used with ball nuts offer high efficiencies and long life, at an economical price. These ball screw assemblies are typically used when a complete positioning system is too costly, or does not fit the users exact positioning system requirements. When combined with linear bearings & rails, a custom positioning system can be created. These ball screw positioning components are designed to allow for numerous options: rotary encoders, different diameter and lead combinations, solid Turcite nuts, power-off electric brakes, and motor wrap packages.

Available Options

Simple, Fixed, Rigid Housings

These bearing support housings provide for different thrust and speed characteristics when combined with the numerous ball screw diameter and lead combinations.

NEMA Motor Mounts

NEMA motor mounts can be easily mounted to any fixed or rigid housing at the factory, or in the field. These motor mounts provide for a direct interface to a NEMA 23, 34, or 42 motor. Utilizing these motor mount options ensures correct centerline alignment of the motor shaft to the ball screw shaft.

Rotary Encoders

Incremental rotary encoders can be mounted to a bearing support housing in order to provide positional data back to either a motion controller, or a digital display.

Solid Turcite Nuts

Some of the RS series screws are available with a Turcite nut. This polymer nut can provide smoother motion and less audible noise than most ball nuts that use recirculating balls. It also is ideal for corrosive environments and vertical applications.

Nut Flanges

Three different nut flange styles (round, vertical, and "L" bracket) are available which allow for a direct interface of the user mounted load, or carriage assembly, to the nut. All three styles are precision machined from steel for high strength and rigidity.

English or Metric Versions

The PS and GS series offer both English and Metric screw options. Motor mounts and nut flanges can be ordered with either English or Metric mounting hardware. For convenience, all dimensions in this catalog are shown in both English and Metric.

Other

Each RS, PS, and GS series ball screw assembly can accommodate **power-off electric brakes** for static load locking applications, numerous **motor couplings** for non-NEMA motors, and **motor wrap packages** for space limited applications.

Standard Features

- Precision machined steel bearing housings with black oxide finish
- 0° F to +185° F (-18° C to +85° C) ball nut operating temperature
- Fixed and rigid housings have shoulder for NEMA motor mounts
- Base and face mount integral to each support housing
- Specify desired thread length for all sizes
- Ball and solid Turcite nuts available
- Four support configurations

Simple - Simple



Fixed - Simple



Rigid - Simple



Rigid - Rigid



Options

- AUTOCAD® drawings available upon request
- NEMA 23, 34, and 42 motor wrap packages
- NEMA 23, 34, and 42 motor mounts
- Preloaded and non-preloaded nuts
- Chrome plated screw and nut
- English and metric versions
- Non-NEMA motor mounts
- Power-off electric brakes
- Motor couplings
- Rotary encoders
- Nut Flanges
- Ball screws:

Rolled - Non-preloaded & Preloaded Nuts:

- 0.500 inch diameter, 0.200 inch lead
- 0.500 inch diameter, 0.500 inch lead
- 0.625 inch diameter, 0.200 inch lead
- 0.625 inch diameter, 1.000 inch lead
- 0.750 inch diameter, 0.200 inch lead
- 0.750 inch diameter, 0.500 inch lead
- 1.000 inch diameter, 0.250 inch lead
- 1.000 inch diameter, 0.500 inch lead
- 1.000 inch diameter, 1.000 inch lead
- 1.500 inch diameter, 0.250 inch lead
- 1.500 inch diameter, 0.500 inch lead
- 1.500 inch diameter, 1.000 inch lead
- 1.500 inch diameter, 2.000 inch lead

Precision - Non-preloaded & Preloaded Nuts:

- 0.625 inch diameter, 0.200 inch lead
- 0.750 inch diameter, 0.200 inch lead
- 16 mm diameter, 5 mm lead
- 16 mm diameter, 10 mm lead
- 16 mm diameter, 16 mm lead
- 20 mm diameter, 5 mm lead
- 20 mm diameter, 20 mm lead

Ground - Preloaded Nuts Only:

- 0.625 inch diameter, 0.200 inch lead
- 0.750 inch diameter, 0.200 inch lead
- 16 mm diameter, 5 mm lead
- 16 mm diameter, 16 mm lead
- 20 mm diameter, 5 mm lead
- 20 mm diameter, 20 mm lead

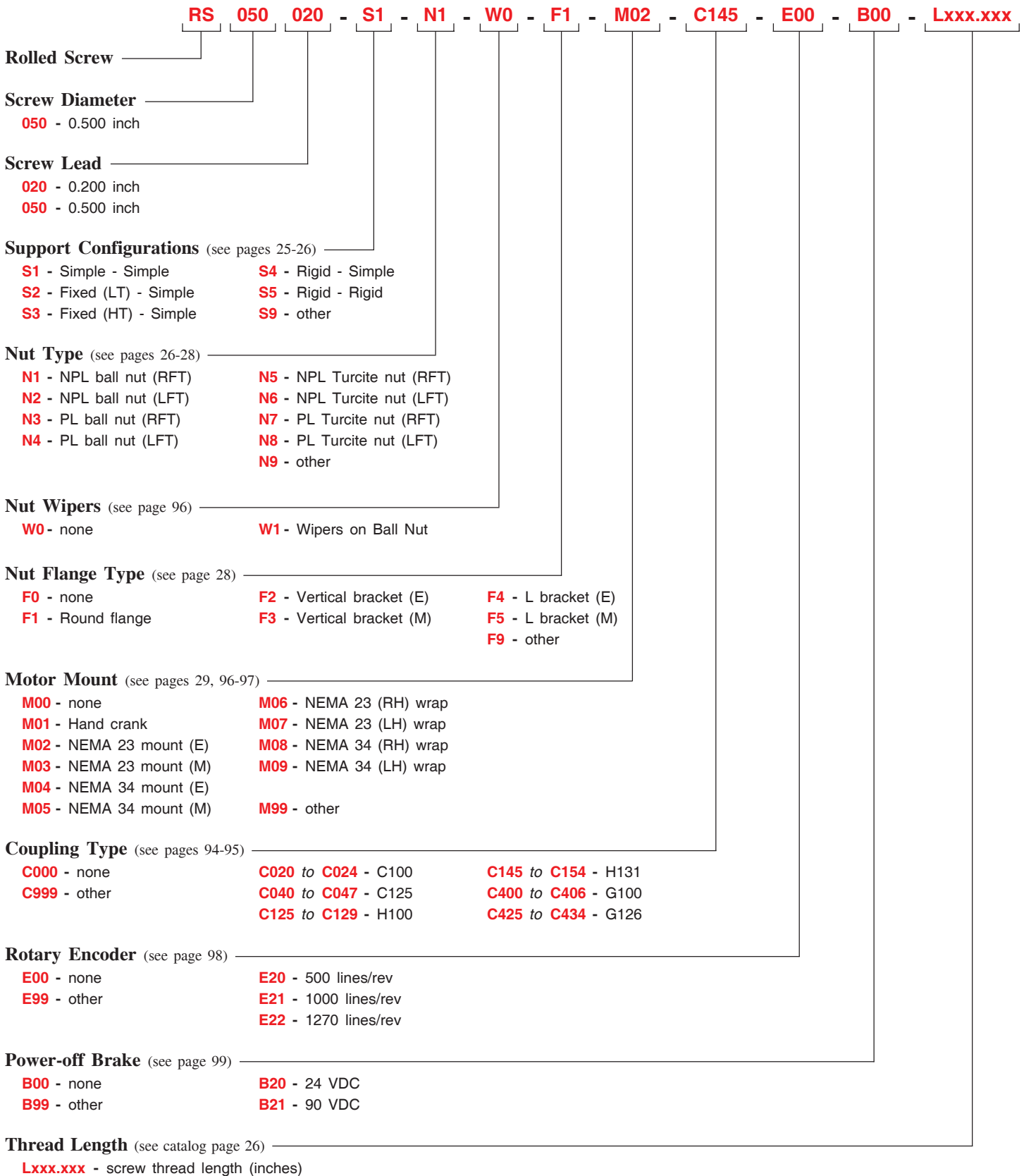

Note: See page 14 for a complete description of the above part number system.

- | | |
|----------------------------|-----------------------------|
| (E) - English Interface | (M) - Metric Interface |
| (LFT) - Left Facing Thread | (NPL) - Non Preloaded |
| (LH) - Left Hand | (PL) - Preloaded |
| (LT) - Low Thrust | (RFT) - Right Facing Thread |
| (HT) - High Thrust | (RH) - Right Hand |

Specifications subject to change without notice

Screw & Nut Specifications

Made in the U.S.A.

Model Number	Nut Type	Diameter inches (mm)	Lead inches (mm)	Root Diameter inches (mm)	Ball Diameter inches (mm)	Number of Circuits	Static Load lbs (kgf)	Dynamic Load ⁽¹⁾ lbs (kgf)
RS050020 0.500 inch dia. 0.200 inch lead	<i>Non-preloaded Ball (N1/N2)</i>	0.500 (12,70)	0.200 (5,08)	0.405 (10,28)	0.125 (3,17)	2	9,400 (4263)	1,200 (544)
	<i>Preloaded Ball (N3/N4)</i>						9,280 (4209)	1,080 (489)
	<i>Non-preloaded Turcite (N5/N6)</i>				n/a	n/a	800 (362)	100 (45)
	<i>Preloaded Turcite (N7/N8)</i>				n/a	n/a	800 (362)	90 (41)
RS050050 0.500 inch dia. 0.500 inch lead	<i>Non-preloaded Ball (N1/N2)</i>	0.500 (12,70)	0.500 (12,70)	0.405 (10,28)	0.125 (3,17)	2	13,350 (6055)	2,200 (997)
	<i>Preloaded Ball (N3/N4)</i>						13,130 (5955)	1,980 (898)
	<i>Non-preloaded Turcite (N5/N6)</i>				n/a	n/a	800 (362)	100 (45)
	<i>Preloaded Turcite (N7/N8)</i>				n/a	n/a	800 (362)	90 (41)

Other Specifications

Maximum Acceleration Rate	Ball nut: 772 inches/sec ² (19.6 m/sec ²) Turcite nut: 193 inches/sec ² (4.9 m/sec ²)
Maximum Speed	Ball nut: 3000 rpm Turcite nut: 1500 rpm
Screw Material Screw Extensions	Right Hand Thread, Case Hardened Rc 58 Steel Rolled Ball Screw 303 Woodruff Keyways on Extensions from Support Housings
Screw Maximum Length ⁽²⁾ Screw Weight	72 inches (1828 mm) 0.66 lbs/ft (9,1 kg/cm)
Support Housings Support Housing Features	Steel with Black Oxide Finish, 45° Chamfer x .02 inch (0,50) all Straight Edges Base or Face Mount with Integral Seals
Nut Flanges Nut Flange Features	Steel with Black Oxide Finish English or Metric Load Mounting Interface

Footnotes:

(1) Load based upon 1 million inches (25 Km) of travel life. See page 27 for further travel life ratings.

(2) Maximum stock length (not the maximum thread length with bearing housings). See page 26 for maximum thread lengths for each configuration.

Screw Specifications

Made in the U.S.A.

Model Number	Nut Type	Screw Efficiency %	Lead Error inch/ft (mm/300 mm)	Backlash inches (mm)	Unidirectional Repeatability inches (mm)	Bidirectional Repeatability inches (mm)
RS050020 0.500 inch dia. 0.200 inch lead	<i>Non-preloaded Ball (N1/N2)</i>	90	< 0.003 (0,075)	0	+/- 0.0002 (0,0050)	+ 0.0002 to - 0.0082 (0,0050) (0,2082)
	<i>Preloaded Ball (N3/N4)</i>					+ 0.0002 to - 0.0002 (0,0050) (0,0050)
RS050050 0.500 inch dia. 0.500 inch lead	<i>Non-preloaded Turcite (N5/N6)</i>	60	< 0.003 (0,075)	0	+/- 0.0002 (0,0050)	+ 0.0002 to - 0.0082 (0,0050) (0,2082)
	<i>Preloaded Turcite (N7/N8)</i>					+ 0.0002 to - 0.0002 (0,0050) (0,0050)

Assembly Specifications

Model Number	Nut Type	Breakaway Torque oz-in (N-m)				
		Simple-Simple	Fixed(LT)-Simple	Fixed(HT)-Simple	Rigid-Simple	Rigid-Rigid
RS050020 0.500 inch dia. 0.200 inch lead	<i>Non-preloaded Ball (N1/N2)</i>	< 8 (0,06)	< 10 (0,07)	< 20 (0,14)	< 20 (0,14)	< 30 (0,21)
	<i>Preloaded Ball (N3/N4)</i>	< 15 (0,11)	< 20 (0,14)	< 30 (0,21)	< 30 (0,21)	< 40 (0,28)
	<i>Non-preloaded Turcite (N5/N6)</i>	< 10 (0,07)	< 15 (0,11)	< 30 (0,21)	< 30 (0,21)	< 40 (0,28)
	<i>Preloaded Turcite (N7/N8)</i>	< 25 (0,18)	< 30 (0,21)	< 45 (0,32)	< 45 (0,32)	< 55 (0,39)
RS050050 0.500 inch dia. 0.500 inch lead	<i>Non-preloaded Ball (N1/N2)</i>	< 10 (0,07)	< 15 (0,11)	< 25 (0,18)	< 25 (0,18)	< 35 (0,25)
	<i>Preloaded Ball (N3/N4)</i>	< 25 (0,18)	< 30 (0,21)	< 40 (0,28)	< 40 (0,28)	< 45 (0,32)
	<i>Non-preloaded Turcite (N5/N6)</i>	< 20 (0,14)	< 25 (0,18)	< 35 (0,25)	< 35 (0,25)	< 45 (0,32)
	<i>Preloaded Turcite (N7/N8)</i>	< 35 (0,25)	< 40 (0,28)	< 50 (0,35)	< 50 (0,35)	< 60 (0,42)

Support Housing Specifications

Made in the U.S.A.

Support Housing Life millions of screw revolutions	Support Housing Thrust Load Capacity - (Axial)			
	Simple	Fixed (LT)	Fixed (HT)	Rigid
Static	1,076 (488)	1,355 (615)	2,160 (980)	2,160 (980)
1	1,076 (488)	1,355 (615)	1,955 (887)	1,955 (887)
2	910 (413)	1,145 (519)	1,550 (703)	1,550 (703)
10	530 (240)	665 (302)	905 (410)	905 (410)
50	310 (141)	395 (179)	530 (240)	530 (240)
100	245 (111)	305 (138)	420 (190)	420 (190)
500	145 (66)	180 (82)	245 (111)	245 (111)

Thrust force applied in either direction

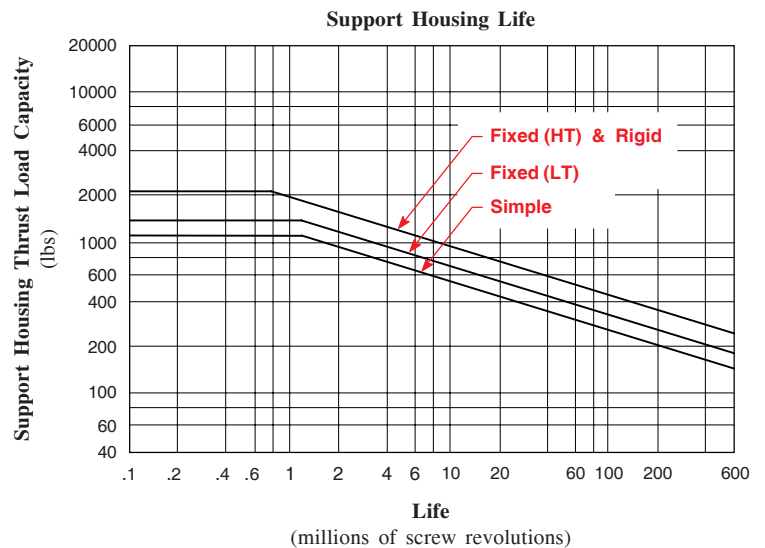
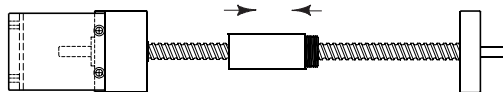

Note: Multiply screw revolutions by the screw lead in order to convert to inches (or mm) traveled by the nut.

Available Configurations

Made in the U.S.A.

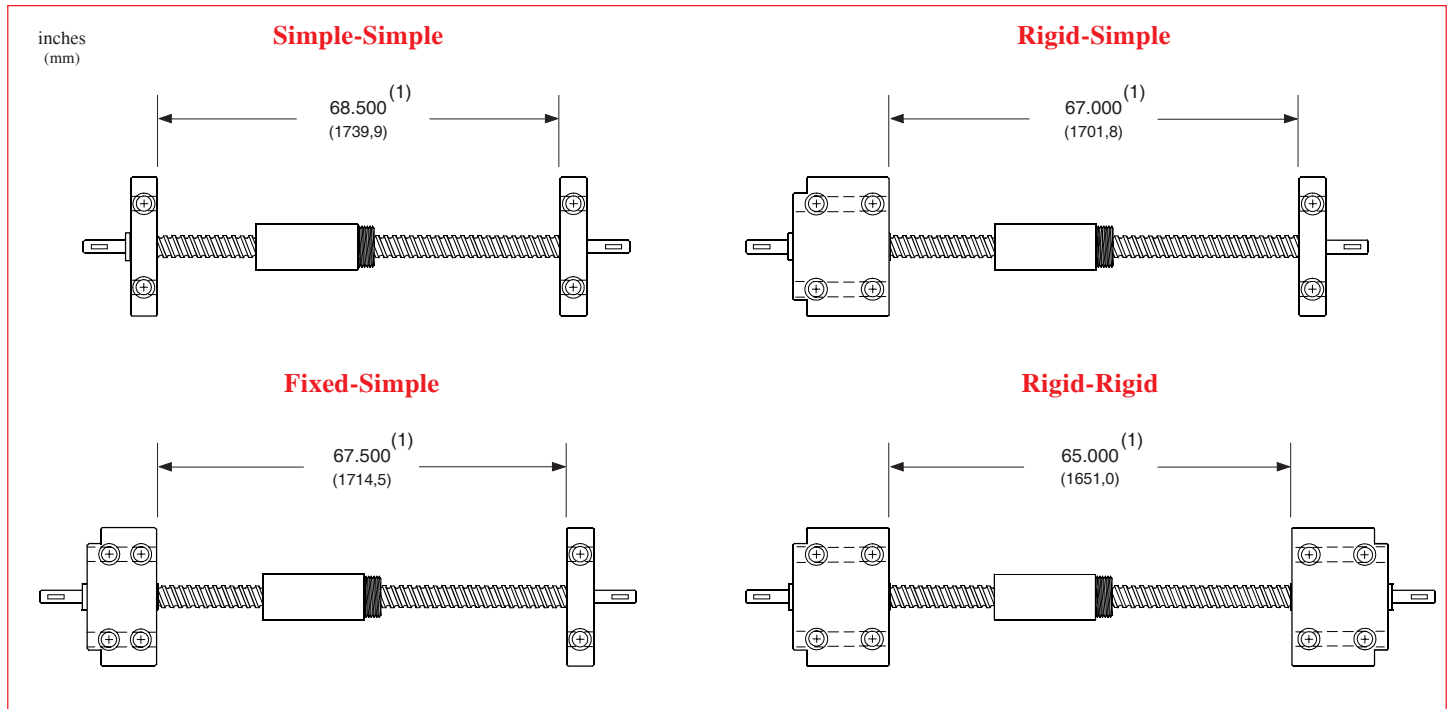

Overall Length Diagram

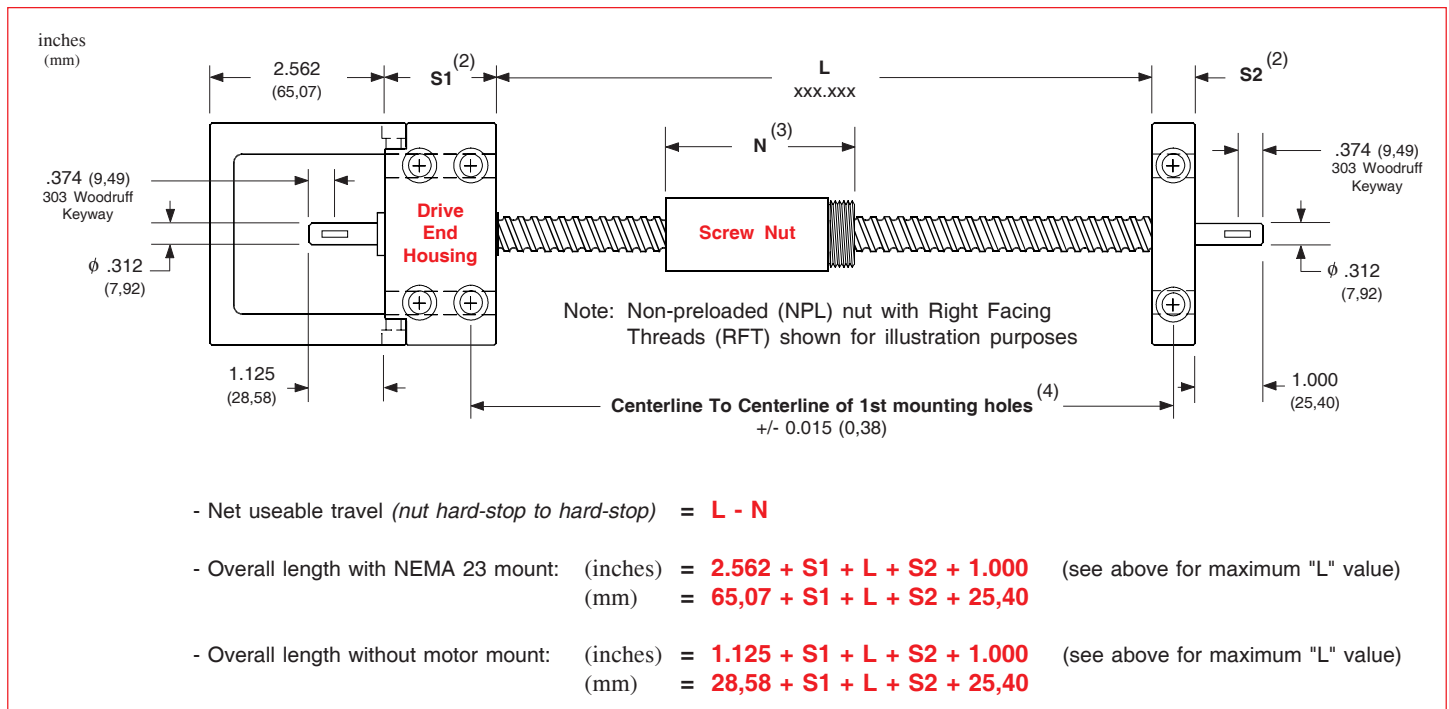

Footnotes:

- (1) Maximum available standard screw thread length for the bearing support housing configuration shown.
- (2) Fixed-simple support configuration shown for reference. See page 29 for length values for simple, fixed, and rigid housings.
- (3) See page 28 for available nut styles. Refer to A1 & A2 values for the nut length.
- (4) Tolerance shown is for base mounted support housings. Tolerance also applies to face mounted support housings.

Performance Charts

Made in the U.S.A.

Simple-Simple

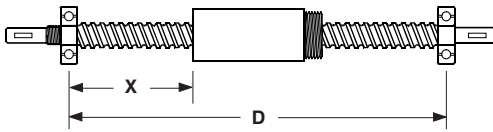

Rigid-Simple

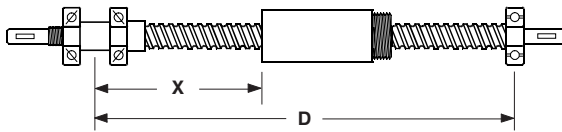

Rigid-Rigid

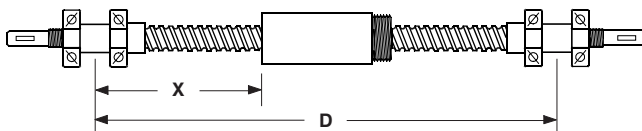

Maximum Compression Load ⁽¹⁾

X inches (mm)	simple-simple		rigid-simple		rigid-rigid	
	lbs	(kgf)	lbs	(kgf)	lbs	(kgf)
20 (508)	756	(343)	1512	(686)	3024	(1372)
40 (1016)	189	(86)	378	(171)	756	(343)
60 (1524)	84	(38)	168	(76)	336	(152)

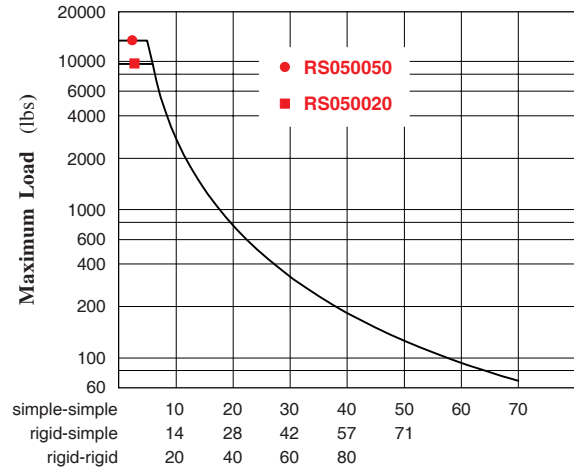

Maximum "X" distance between bearing support and Load (inches)

Maximum Speed ⁽¹⁾

D inches (mm)	simple-simple		rigid-simple		rigid-rigid	
	rpm	rpm	rpm	rpm	rpm	rpm
23 (584)	3000	3000	3000	3000	3000	3000
40 (1016)	1075	1580	1580	2395	2395	2395
60 (1524)	475	700	700	1060	1060	1060
70 (1778)	340	510	510	775	775	775

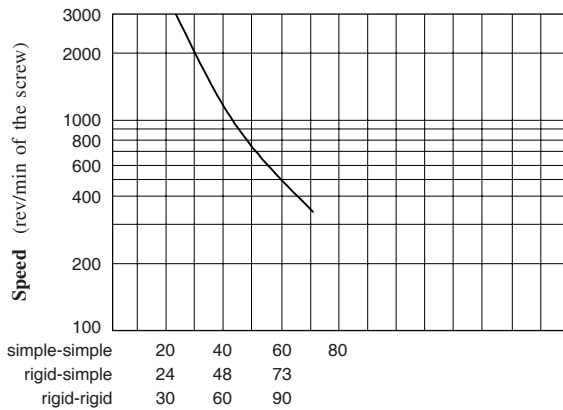

Maximum "D" distance between bearing supports (inches)

Screw Travel Life ⁽²⁾

Life millions of inches (km)	050020		050050		Turcite Nut	
	lbs	(kgf)	lbs	(kgf)	lbs	(kgf)
1 (25)	1200	(544)	2200	(997)	100	(45)
2 (50)	970	(440)	1780	(807)	80	(36)
50 (1270)	350	(158)	640	(290)	29	(13)
100 (2540)	290	(131)	530	(240)	24	(11)

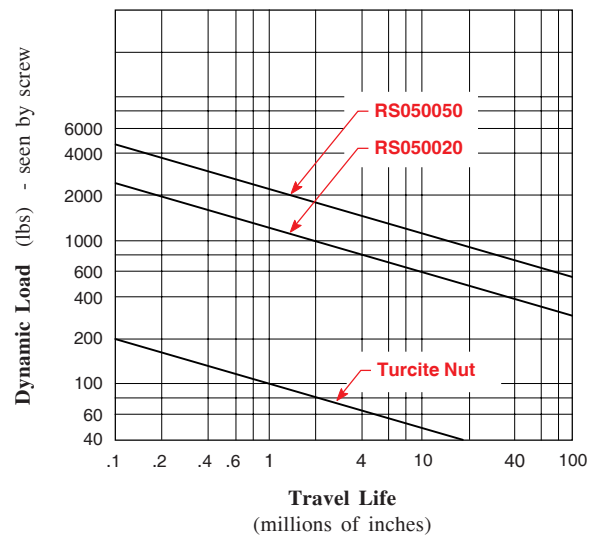

Footnotes:

- Refer to the simple-simple support lengths for fixed-simple configurations. A fixed housing performs like a simple housing for critical speed and compression load specifications. Maximum speeds may not be reached using a Turcite nut due to system friction.
- Multiply life value from chart (or graph) by 0.90 to obtain the life for a preloaded ball nut.

Specifications subject to change without notice

Nut Dimensions

Made in the U.S.A.

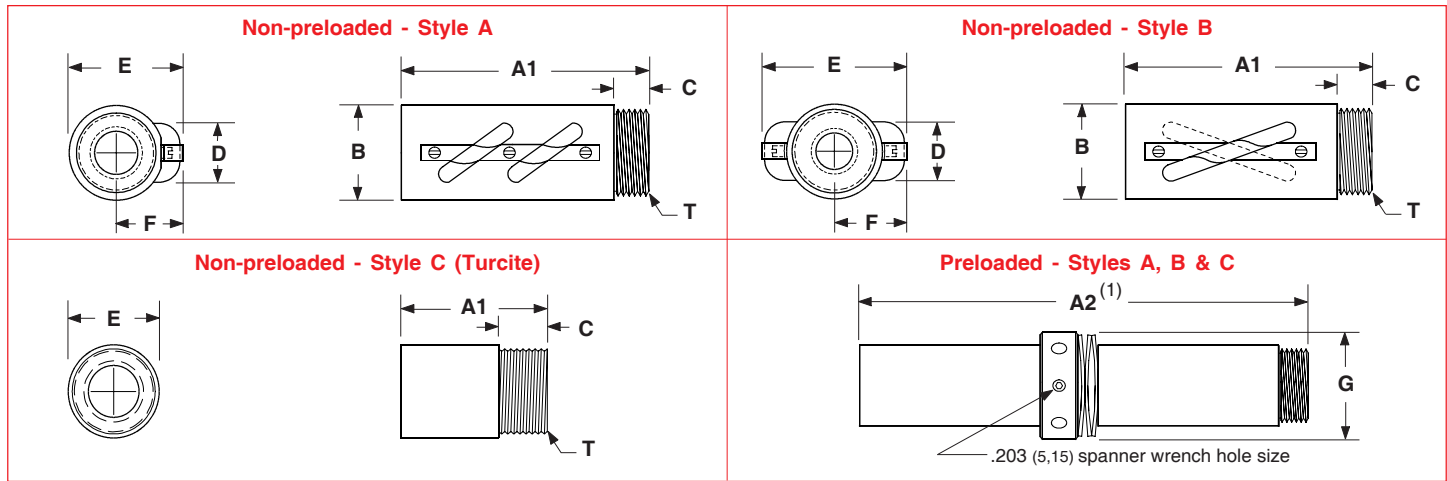

Nut Flange Dimensions

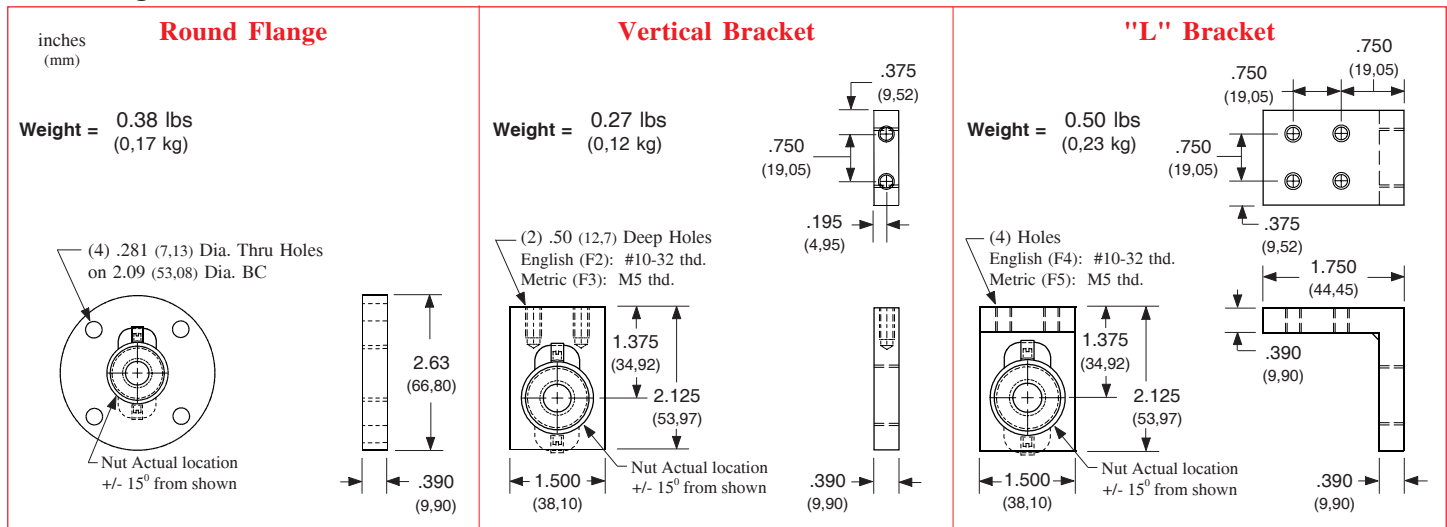

Model Number	Nut Style	Nut Dimensions inches (mm)									Nut Weight ⁽³⁾ lbs (kg)
		A1	A2 ⁽¹⁾	B	C	D	E	F	T - "V" Threads ⁽²⁾	G	
RS050020	A	2.760 (70,10)	6.050 (153,67)	1.067 (27,10)	0.390 (9,90)	0.665 (16,89)	1.339 (34,01)	0.850 (21,59)	15/16 - 16 UN-2A (23,81 - 16 UN-2A)	1.420 (36,07)	0.75 (0,34)
RS050050	B	2.760 (70,10)	6.050 (153,67)	1.070 (27,18)	0.390 (9,90)	0.667 (16,94)	1.630 (41,40)	0.860 (21,84)	15/16 - 16 UN-2A (23,81 - 16 UN-2A)	1.420 (36,07)	0.50 (0,22)
RS050020	C	1.020 (25,91)	2.550 (64,77)	n/a	0.390 (9,90)	n/a	1.000 (25,40)	n/a	15/16 - 16 UN-2A (23,81 - 16 UN-2A)	n/a	0.20 (0,09)
RS050050	C	1.020 (25,91)	2.550 (64,77)	n/a	0.390 (9,90)	n/a	1.000 (25,40)	n/a	15/16 - 16 UN-2A (23,81 - 16 UN-2A)	n/a	0.20 (0,09)

Footnotes:

- (1) This is the length for a preloaded nut. Preloaded nut consists of two (2) non-preloaded nuts with a locking spanner nut, and belville springs.
- (2) All flange threads are internal (Type 2B) to match the external nut threads.
- (3) Weight of the non-preloaded nut. Multiply value by 2.1 to obtain the weight for the preloaded nut assembly.

Specifications subject to change without notice

Support Housing Dimensions

Made in the U.S.A.

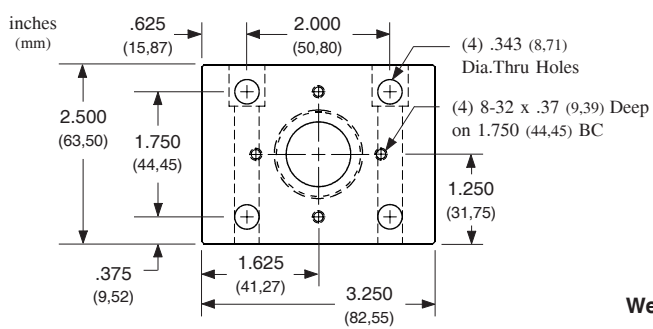

Simple

Weight = 1.1 lbs (0,50 kg)

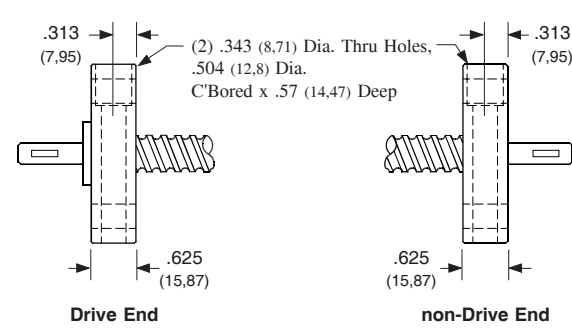

Weight = 1.1 lbs (0,50 kg)

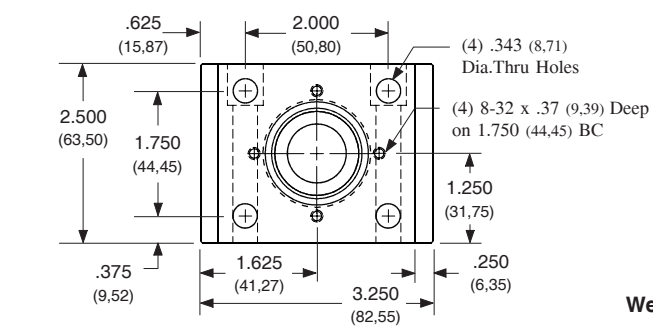

Fixed

Weight = 2.6 lbs (1,18 kg)

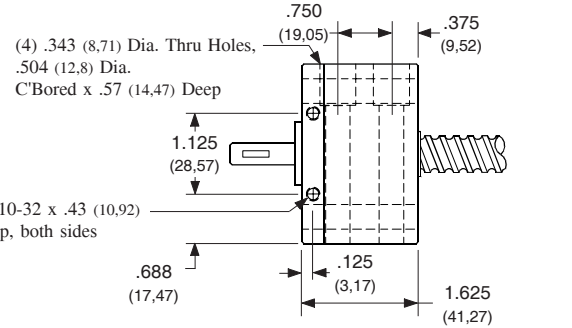

Weight = 2.6 lbs (1,18 kg)

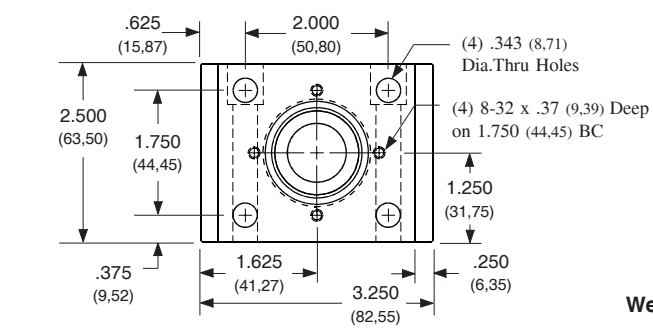

Rigid

Weight = 3.8 lbs (1,72 kg)

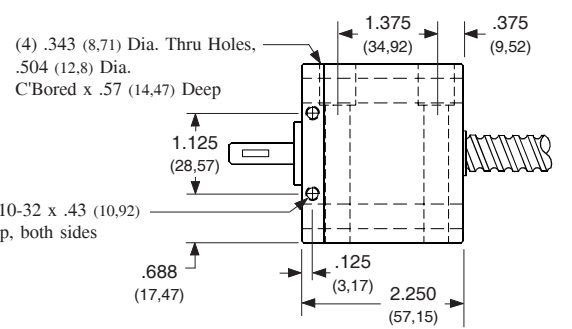

Weight = 3.8 lbs (1,72 kg)

NEMA 23 Motor Mount

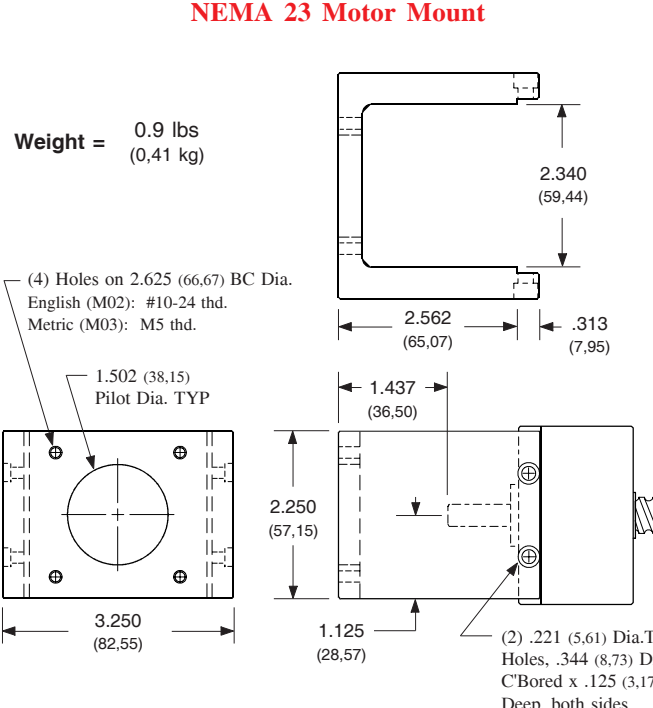

Weight = 0.9 lbs (0,41 kg)

NEMA 34 Motor Mount

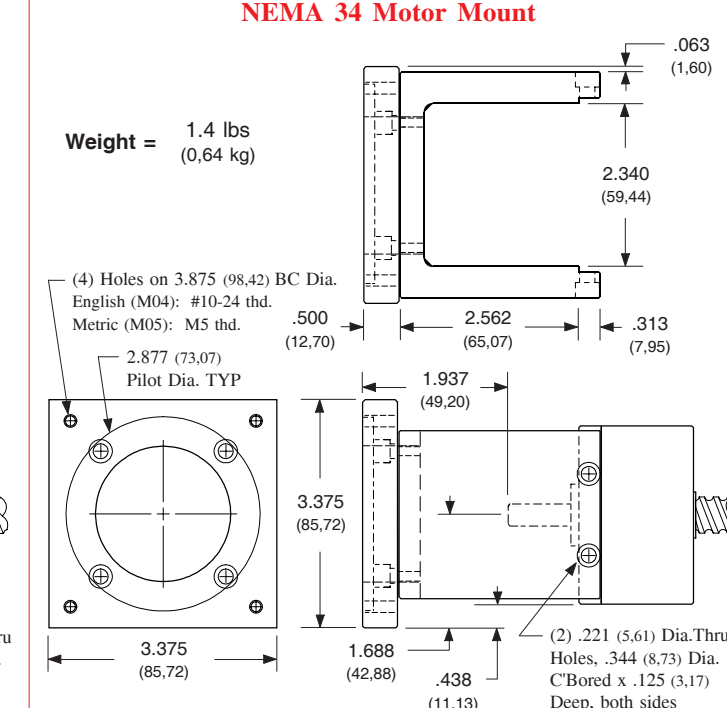

Weight = 1.4 lbs (0,64 kg)

Specifications subject to change without notice

LINTECH® Positioning Components

29

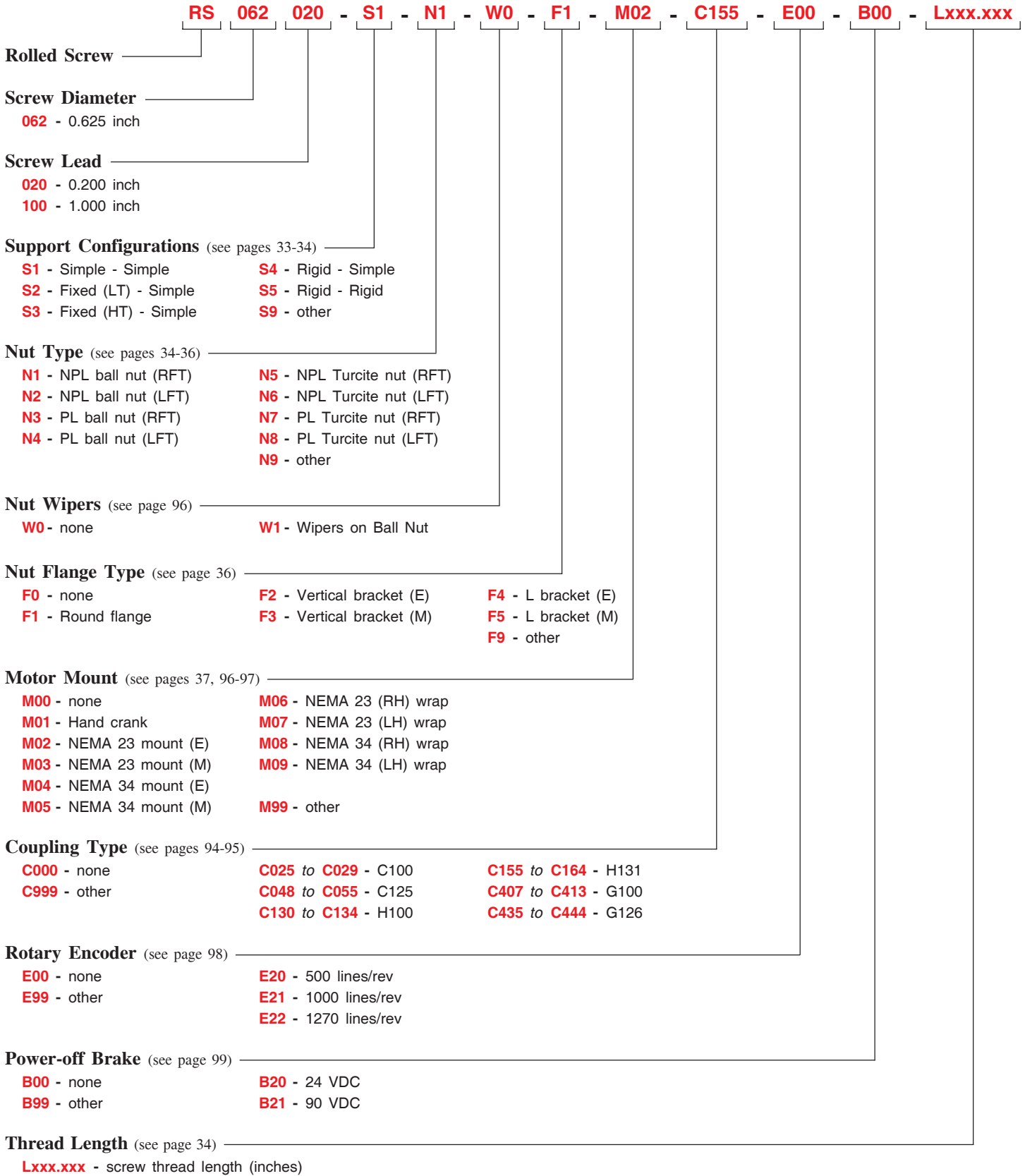

Note: See page 14 for a complete description of the above part number system.

- | | |
|----------------------------|-----------------------------|
| (E) - English Interface | (M) - Metric Interface |
| (LFT) - Left Facing Thread | (NPL) - Non Preloaded |
| (LH) - Left Hand | (PL) - Preloaded |
| (LT) - Low Thrust | (RFT) - Right Facing Thread |
| (HT) - High Thrust | (RH) - Right Hand |

Specifications subject to change without notice

Screw & Nut Specifications

Made in the U.S.A.

Model Number	Nut Type	Diameter inches (mm)	Lead inches (mm)	Root Diameter inches (mm)	Ball Diameter inches (mm)	Number of Circuits	Static Load lbs (kgf)	Dynamic Load ⁽¹⁾ lbs (kgf)
RS062020 0.625 inch dia. 0.200 inch lead	<i>Non-preloaded Ball (N1/N2)</i>	0.625 (15,87)	0.200 (5,08)	0.503 (12,77)	0.125 (3,17)	1	6,150 (2790)	800 (363)
	<i>Preloaded Ball (N3/N4)</i>						6,070 (2753)	720 (326)
	<i>Non-preloaded Turcite (N5/N6)</i>				800 (362)	100 (45)		
	<i>Preloaded Turcite (N7/N8)</i>				800 (362)	90 (41)		
RS062100 0.625 inch dia. 1.000 inch lead	<i>Non-preloaded Ball (N1/N2)</i>	0.625 (15,87)	1.000 (25,40)	0.505 (12,82)	0.125 (3,17)	2	2,425 (1100)	590 (267)
	<i>Preloaded Ball (N3/N4)</i>						2,390 (1084)	530 (240)
	<i>Non-preloaded Turcite (N5/N6)</i>				800 (362)	100 (45)		
	<i>Preloaded Turcite (N7/N8)</i>				800 (362)	90 (41)		

Other Specifications

Maximum Acceleration Rate	Ball nut: 772 inches/sec ² (19.6 m/sec ²) Turcite nut: 193 inches/sec ² (4.9 m/sec ²)
Maximum Speed	Ball nut: 3000 rpm Turcite nut: 1500 rpm
Screw Material Screw Extensions	Right Hand Thread, Case Hardened Rc 58 Steel Rolled Ball Screw 303 Woodruff Keyways on Extensions from Support Housings
Screw Maximum Length ⁽²⁾ Screw Weight	72 inches (1828 mm) 0.92 lbs/ft (12,7 kg/cm)
Support Housings Support Housing Features	Steel with Black Oxide Finish, 45° Chamfer x .02 inch (0,50) all Straight Edges Base or Face Mount with Integral Seals
Nut Flanges Nut Flange Features	Steel with Black Oxide Finish English or Metric Load Mounting Interface

Footnotes:

(1) Load based upon 1 million inches (25 Km) of travel life. See page 35 for further travel life ratings.

(2) Maximum stock length (not the maximum thread length with bearing housings). See page 34 for maximum thread lengths for each configuration.

Screw Specifications

Made in the U.S.A.

Model Number	Nut Type	Screw Efficiency %	Lead Error inch/ft (mm/300 mm)	Backlash inches (mm)	Unidirectional Repeatability inches (mm)	Bidirectional Repeatability inches (mm)
RS062020 0.625 inch dia. 0.200 inch lead	<i>Non-preloaded</i> Ball (N1/N2)	90	< 0.003 (0,075)	< 0.008 (0,203)	+/- 0.0002 (0,0050)	+ 0.0002 to - 0.0082 (0,0050) (0,2082)
	<i>Preloaded</i> Ball (N3/N4)					+ 0.0002 to - 0.0002 (0,0050) (0,0050)
	<i>Non-preloaded</i> Turcite (N5/N6)	60	< 0.003 (0,075)	< 0.008 (0,203)	+/- 0.0002 (0,0050)	+ 0.0002 to - 0.0082 (0,0050) (0,2082)
	<i>Preloaded</i> Turcite (N7/N8)					+ 0.0002 to - 0.0002 (0,0050) (0,0050)
RS062100 0.625 inch dia. 1.000 inch lead	<i>Non-preloaded</i> Ball (N1/N2)	90	< 0.004 (0,099)	< 0.008 (0,203)	+/- 0.0002 (0,0050)	+ 0.0002 to - 0.0082 (0,0050) (0,2082)
	<i>Preloaded</i> Ball (N3/N4)					+ 0.0002 to - 0.0002 (0,0050) (0,0050)
	<i>Non-preloaded</i> Turcite (N5/N6)	60	< 0.004 (0,099)	< 0.008 (0,203)	+/- 0.0002 (0,0050)	+ 0.0002 to - 0.0082 (0,0050) (0,2082)
	<i>Preloaded</i> Turcite (N7/N8)					+ 0.0002 to - 0.0002 (0,0050) (0,0050)

Assembly Specifications

Model Number	Nut Type	Breakaway Torque oz-in (N-m)				
		Simple-Simple	Fixed(LT)-Simple	Fixed(HT)-Simple	Rigid-Simple	Rigid-Rigid
RS062020 0.625 inch dia. 0.200 inch lead	<i>Non-preloaded</i> Ball (N1/N2)	< 8 (0,06)	< 10 (0,07)	< 20 (0,14)	< 20 (0,14)	< 30 (0,21)
	<i>Preloaded</i> Ball (N3/N4)	< 15 (0,11)	< 20 (0,14)	< 30 (0,21)	< 30 (0,21)	< 40 (0,28)
	<i>Non-preloaded</i> Turcite (N5/N6)	< 10 (0,07)	< 15 (0,11)	< 30 (0,21)	< 30 (0,21)	< 40 (0,28)
	<i>Preloaded</i> Turcite (N7/N8)	< 25 (0,18)	< 30 (0,21)	< 45 (0,32)	< 45 (0,32)	< 55 (0,39)
RS062100 0.625 inch dia. 1.000 inch lead	<i>Non-preloaded</i> Ball (N1/N2)	< 15 (0,11)	< 25 (0,18)	< 40 (0,28)	< 40 (0,28)	< 50 (0,35)
	<i>Preloaded</i> Ball (N3/N4)	< 30 (0,21)	< 40 (0,28)	< 55 (0,39)	< 55 (0,39)	< 65 (0,45)
	<i>Non-preloaded</i> Turcite (N5/N6)	< 25 (0,18)	< 35 (0,25)	< 50 (0,35)	< 50 (0,35)	< 60 (0,42)
	<i>Preloaded</i> Turcite (N7/N8)	< 50 (0,35)	< 60 (0,42)	< 75 (0,53)	< 75 (0,53)	< 85 (0,60)

Specifications subject to change without notice

Support Housing Specifications

Made in the U.S.A.

Support Housing Life millions of screw revolutions	Support Housing Thrust Load Capacity - (Axial)			
	Simple	Fixed (LT)	Fixed (HT)	Rigid
Static	1,370 (621)	1,725 (782)	3,105 (1408)	3,105 (1408)
1	1,370 (621)	1,725 (782)	2,875 (1304)	2,875 (1304)
2	1,215 (551)	1,530 (694)	2,195 (996)	2,195 (996)
10	710 (322)	895 (406)	1,295 (587)	1,295 (587)
50	410 (186)	525 (238)	790 (358)	790 (358)
100	330 (150)	415 (188)	630 (286)	630 (286)
500	195 (88)	240 (109)	365 (166)	365 (166)

Thrust force applied in either direction

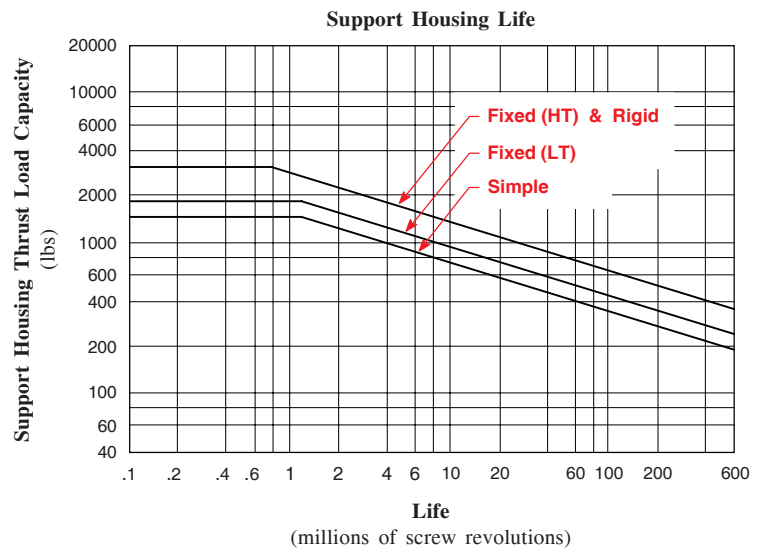
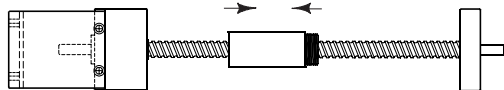

Note: Multiply screw revolutions by the screw lead in order to convert to inches (or mm) traveled by the nut.

Available Configurations

Made in the U.S.A.

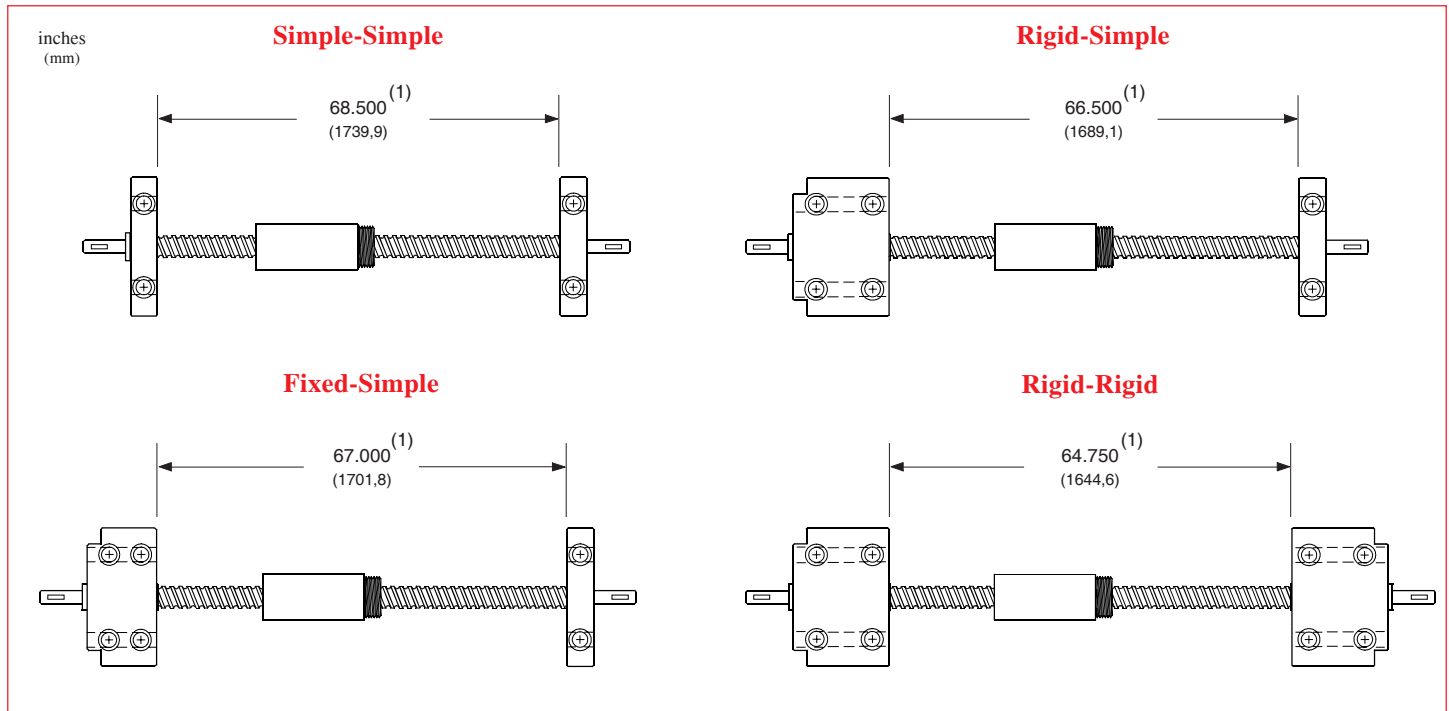

Overall Length Diagram

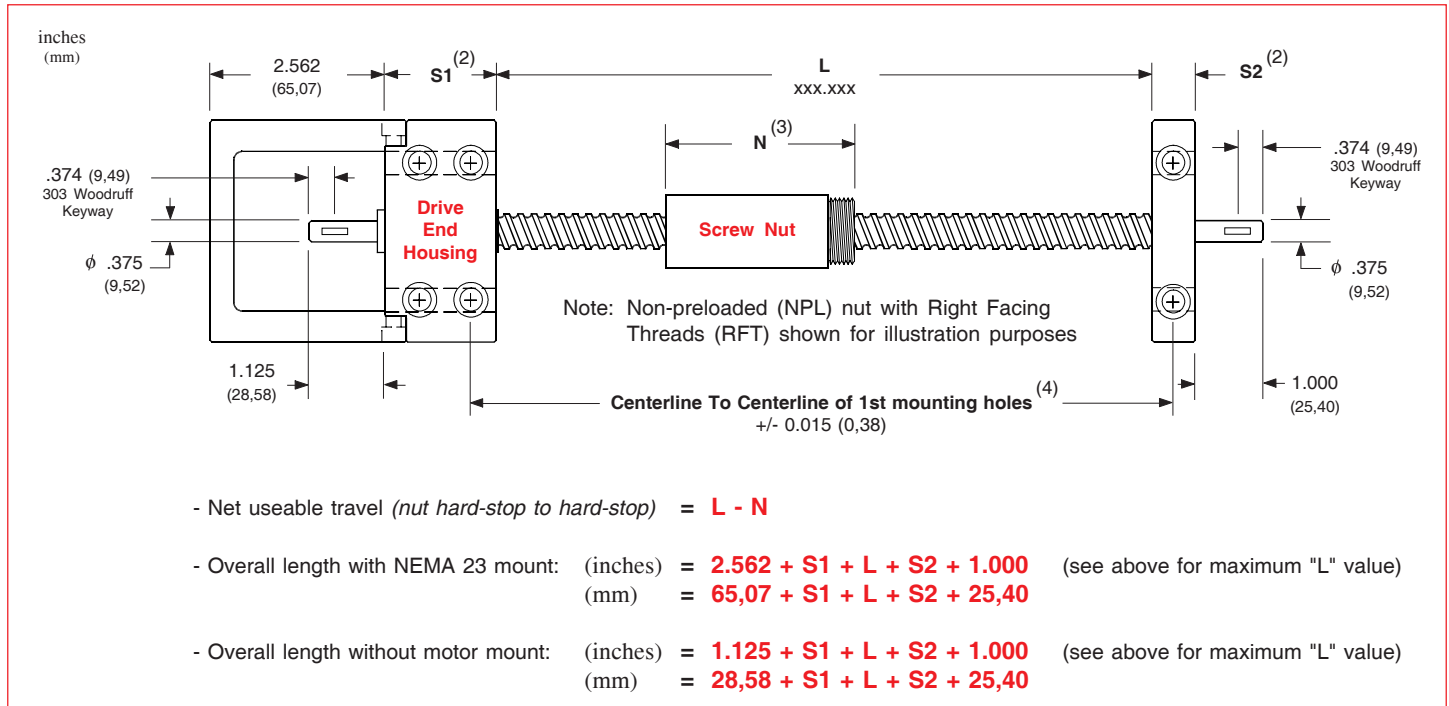

Footnotes:

- (1) Maximum available standard screw thread length for the bearing support housing configuration shown.
- (2) Fixed-simple support configuration shown for reference. See page 37 for length values for simple, fixed, and rigid housings.
- (3) See page 36 for available nut styles. Refer to A1 & A2 values for the nut length.
- (4) Tolerance shown is for base mounted support housings. Tolerance also applies to face mounted support housings.

Performance Charts

Made in the U.S.A.

Simple-Simple

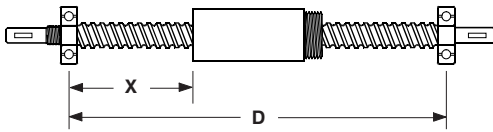

Rigid-Simple

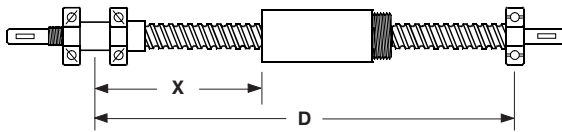

Rigid-Rigid

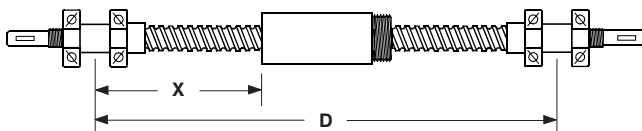

Maximum Compression Load ⁽¹⁾

X inches (mm)	simple-simple		rigid-simple		rigid-rigid	
	lbs	(kgf)	lbs	(kgf)	lbs	(kgf)
20 (508)	1799	(816)	2425	(1100)	2425	(1100)
40 (1016)	450	(204)	900	(408)	1800	(816)
60 (1524)	200	(91)	400	(181)	800	(363)

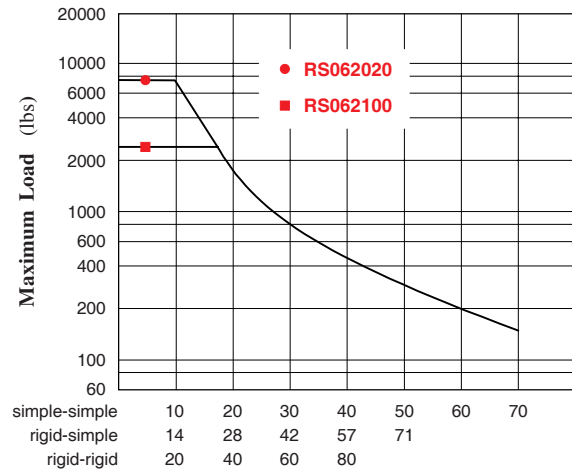

Maximum "X" distance between bearing support and Load (inches)

Maximum Speed ⁽¹⁾

D inches (mm)	simple-simple	rigid-simple	rigid-rigid
	rpm	rpm	rpm
27 (686)	2940	3000	3000
40 (1016)	1340	1970	2990
60 (1524)	595	870	1325
70 (1778)	435	640	970

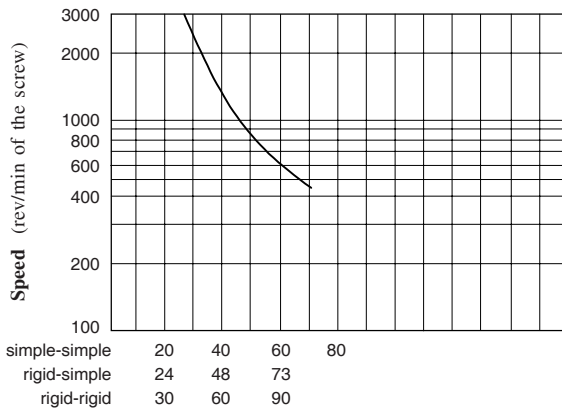

Maximum "D" distance between bearing supports (inches)

Screw Travel Life ⁽²⁾

Life millions of inches (km)	062020		062100		Turcite Nut	
	lbs	(kgf)	lbs	(kgf)	lbs	(kgf)
1 (25)	800	(363)	590	(268)	100	(45)
2 (50)	640	(290)	480	(218)	80	(36)
50 (1270)	230	(104)	170	(77)	29	(13)
100 (2540)	190	(86)	140	(64)	24	(11)

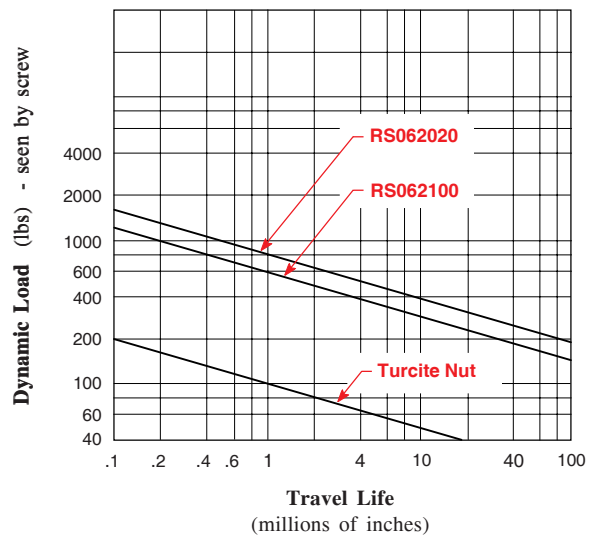

Footnotes:

- Refer to the simple-simple support lengths for fixed-simple configurations. A fixed housing performs like a simple housing for critical speed and compression load specifications. Maximum speeds may not be reached using a Turcite nut due to system friction.
- Multiply life value from chart (or graph) by 0.90 to obtain the life for a preloaded ball nut.

Specifications subject to change without notice

Nut Dimensions

Made in the U.S.A.

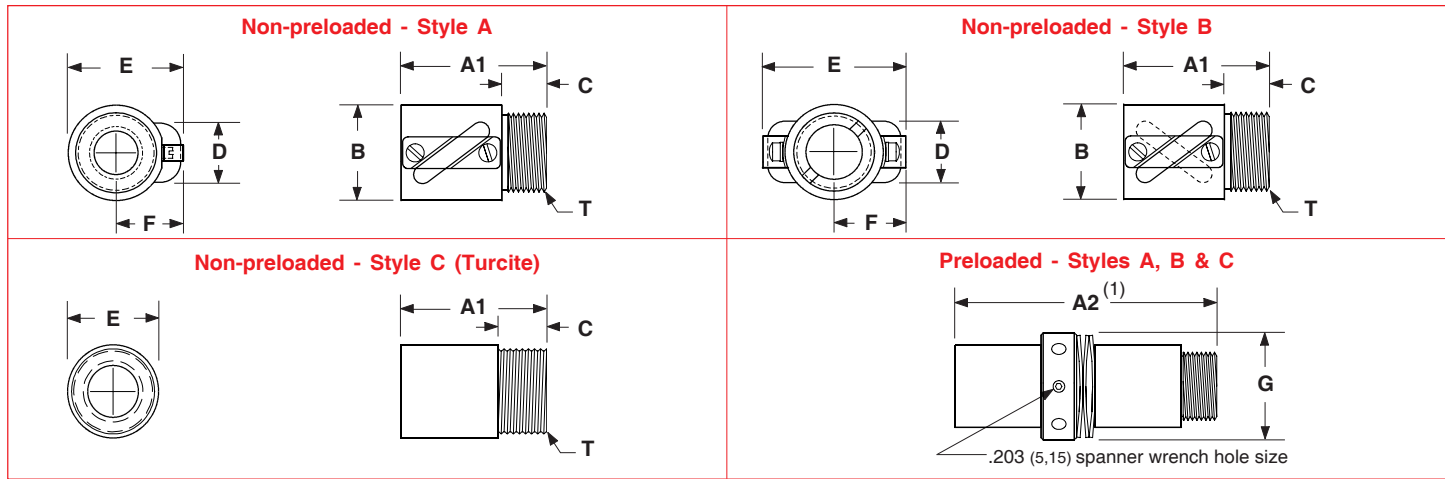

Nut Flange Dimensions

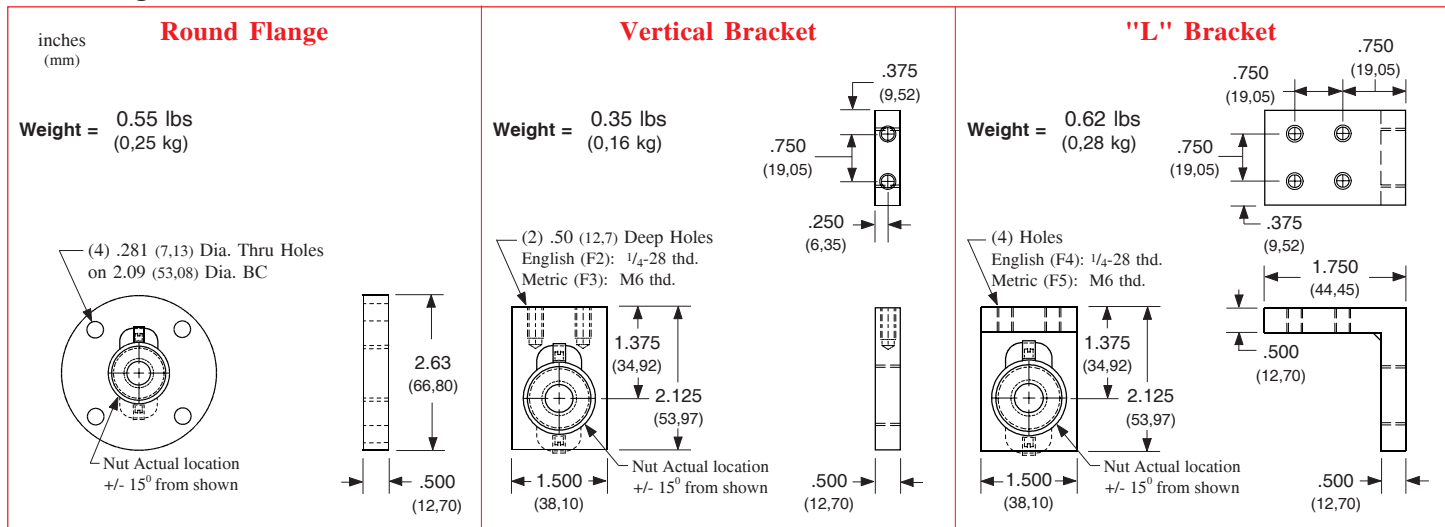

Model Number	Nut Style	Nut Dimensions inches (mm)									Nut Weight ⁽³⁾ lbs (kg)
		A1	A2 ⁽¹⁾	B	C	D	E	F	T - "V" Threads ⁽²⁾	G	
RS062020	A	1.720 (43,69)	3.750 (95,25)	1.130 (28,70)	0.505 (12,83)	0.787 (19,99)	1.360 (34,54)	0.800 (20,32)	15/16 - 16 UN-2A (23,81 - 16 UN-2A)	1.420 (36,07)	0.50 (0,22)
RS062100	B	1.720 (43,69)	3.750 (95,25)	1.125 (28,57)	0.500 (12,70)	0.760 (19,30)	1.654 (42,01)	0.827 (21,00)	15/16 - 16 UN-2A (23,81 - 16 UN-2A)	1.420 (36,07)	0.28 (0,13)
RS062020	C	1.130 (28,70)	2.850 (72,39)	n/a	0.505 (12,83)	n/a	1.000 (25,40)	n/a	15/16 - 16 UN-2A (23,81 - 16 UN-2A)	n/a	0.20 (0,09)
RS062100	C	1.130 (28,70)	2.850 (72,39)	n/a	0.500 (12,70)	n/a	1.000 (25,40)	n/a	15/16 - 16 UN-2A (23,81 - 16 UN-2A)	n/a	0.20 (0,09)

Footnotes:

- (1) This is the length for a preloaded nut. Preloaded nut consists of (2) non-preloaded nuts with a locking spanner nut, and belville springs.
- (2) All flange threads are internal (Type 2B) to match the external nut threads.
- (3) Weight of the non-preloaded nut. Multiply value by 2.1 to obtain the weight for the preloaded nut assembly.

Specifications subject to change without notice

Support Housing Dimensions

Made in the U.S.A.

Simple

Weight = 1.1 lbs (0,50 kg)

Weight = 1.1 lbs (0,50 kg)

Fixed

Weight = 2.7 lbs (1,22 kg)

Weight = 2.7 lbs (1,22 kg)

Rigid

Weight = 3.9 lbs (1,77 kg)

Weight = 3.9 lbs (1,77 kg)

NEMA 23 Motor Mount

Weight = 0.9 lbs (0,41 kg)

(4) Holes on 2.625 (66,67) BC Dia.
English (M02): #10-24 thd.
Metric (M03): M5 thd.

1.502 (38,15) Pilot Dia. TYP

(2) .221 (5,61) Dia.Thru Holes, .344 (8,73) Dia. C'Bored x .125 (3,17) Deep, both sides

NEMA 34 Motor Mount

Weight = 1.4 lbs (0,64 kg)

(4) Holes on 3.875 (98,42) BC Dia.
English (M04): #10-24 thd.
Metric (M05): M5 thd.

2.877 (73,07) Pilot Dia. TYP

(2) .221 (5,61) Dia.Thru Holes, .344 (8,73) Dia. C'Bored x .125 (3,17) Deep, both sides

Specifications subject to change without notice

LINTECH® Positioning Components

37

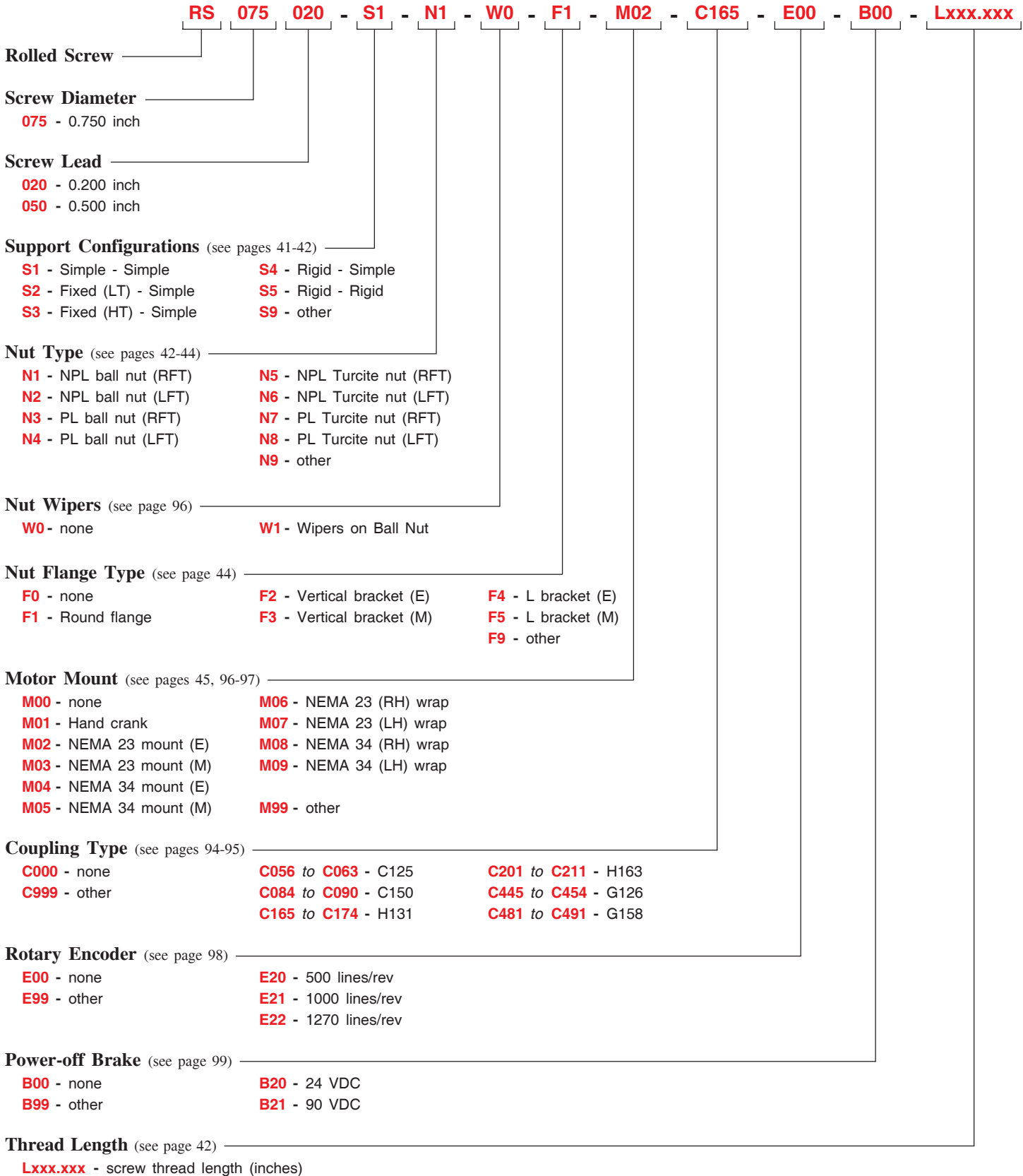

Note: See page 14 for a complete description of the above part number system.

- | | |
|----------------------------|-----------------------------|
| (E) - English Interface | (M) - Metric Interface |
| (LFT) - Left Facing Thread | (NPL) - Non Preloaded |
| (LH) - Left Hand | (PL) - Preloaded |
| (LT) - Low Thrust | (RFT) - Right Facing Thread |
| (HT) - High Thrust | (RH) - Right Hand |

Specifications subject to change without notice

Screw & Nut Specifications

Made in the U.S.A.

Model Number	Nut Type	Diameter inches (mm)	Lead inches (mm)	Root Diameter inches (mm)	Ball Diameter inches (mm)	Number of Circuits	Static Load lbs (kgf)	Dynamic Load ⁽¹⁾ lbs (kgf)
RS075020 0.750 inch dia. 0.200 inch lead	<i>Non-preloaded Ball (N1/N2)</i>	0.750 (19,05)	0.200 (5,08)	0.655 (16,63)	0.125 (3,17)	2	18,800 (8527)	1,900 (862)
	<i>Preloaded Ball (N3/N4)</i>						18,610 (8441)	1,710 (776)
	<i>Non-preloaded Turcite (N5/N6)</i>				n/a	n/a	1,500 (680)	195 (88)
	<i>Preloaded Turcite (N7/N8)</i>				n/a	n/a	1,500 (680)	175 (79)
RS075050 0.750 inch dia. 0.500 inch lead	<i>Non-preloaded Ball (N1/N2)</i>	0.750 (19,05)	0.500 (12,70)	0.629 (15,97)	0.156 (3,96)	2	24,200 (10977)	3,450 (1565)
	<i>Preloaded Ball (N3/N4)</i>						23,855 (10820)	3,105 (1408)
	<i>Non-preloaded Turcite (N5/N6)</i>				n/a	n/a	1,500 (680)	195 (88)
	<i>Preloaded Turcite (N7/N8)</i>				n/a	n/a	1,500 (680)	175 (79)

Other Specifications

Maximum Acceleration Rate	Ball nut: 772 inches/sec ² (19.6 m/sec ²) Turcite nut: 193 inches/sec ² (4.9 m/sec ²)
Maximum Speed	Ball nut: 3000 rpm Turcite nut: 1500 rpm
Screw Material	Right Hand Thread, Case Hardened Rc 58 Steel Rolled Ball Screw
Screw Extensions	Woodruff Keyways on Support Housings - 304 Drive End; 303 Opposite End
Screw Maximum Length ⁽²⁾	72 inches (1828 mm)
Screw Weight	1.42 lbs/ft (19,6 kg/cm)
Support Housings	Steel with Black Oxide Finish, 45° Chamfer x .02 inch (0,50) all Straight Edges
Support Housing Features	Base or Face Mount with Integral Seals
Nut Flanges	Steel with Black Oxide Finish
Nut Flange Features	English or Metric Load Mounting Interface

Footnotes:

(1) Load based upon 1 million inches (25 Km) of travel life. See page 43 for further travel life ratings.

(2) Maximum stock length (not the maximum thread length with bearing housings). See page 42 for maximum thread lengths for each configuration.

Screw Specifications

Made in the U.S.A.

Model Number	Nut Type	Screw Efficiency %	Lead Error inch/ft (mm/300 mm)	Backlash inches (mm)	Unidirectional Repeatability inches (mm)	Bidirectional Repeatability inches (mm)
RS075020 0.750 inch dia. 0.200 inch lead & RS075050 0.750 inch dia. 0.500 inch lead	<i>Non-preloaded Ball (N1/N2)</i>	90	< 0.003 (0,075)	< 0.008 (0,203)	+/- 0.0002 (0,0050)	+ 0.0002 to - 0.0082 (0,0050) (0,2082)
	<i>Preloaded Ball (N3/N4)</i>					+ 0.0002 to - 0.0002 (0,0050) (0,0050)
	<i>Non-preloaded Turcite (N5/N6)</i>	60	< 0.003 (0,075)	< 0.008 (0,203)	+/- 0.0002 (0,0050)	+ 0.0002 to - 0.0082 (0,0050) (0,2082)
	<i>Preloaded Turcite (N7/N8)</i>					+ 0.0002 to - 0.0002 (0,0050) (0,0050)

Assembly Specifications

Model Number	Nut Type	Breakaway Torque oz-in (N-m)				
		Simple-Simple	Fixed(LT)-Simple	Fixed(HT)-Simple	Rigid-Simple	Rigid-Rigid
RS075020 0.750 inch dia. 0.200 inch lead	<i>Non-preloaded Ball (N1/N2)</i>	< 10 (0,07)	< 20 (0,14)	< 30 (0,21)	< 30 (0,21)	< 45 (0,32)
	<i>Preloaded Ball (N3/N4)</i>	< 20 (0,14)	< 30 (0,21)	< 40 (0,28)	< 40 (0,28)	< 55 (0,39)
	<i>Non-preloaded Turcite (N5/N6)</i>	< 15 (0,11)	< 25 (0,18)	< 35 (0,25)	< 35 (0,25)	< 50 (0,35)
	<i>Preloaded Turcite (N7/N8)</i>	< 30 (0,21)	< 40 (0,28)	< 50 (0,35)	< 50 (0,35)	< 65 (0,45)
RS075050 0.750 inch dia. 0.500 inch lead	<i>Non-preloaded Ball (N1/N2)</i>	< 15 (0,11)	< 25 (0,18)	< 35 (0,25)	< 35 (0,25)	< 50 (0,35)
	<i>Preloaded Ball (N3/N4)</i>	< 30 (0,21)	< 40 (0,28)	< 50 (0,35)	< 50 (0,35)	< 65 (0,45)
	<i>Non-preloaded Turcite (N5/N6)</i>	< 25 (0,18)	< 35 (0,25)	< 45 (0,32)	< 45 (0,32)	< 60 (0,42)
	<i>Preloaded Turcite (N7/N8)</i>	< 50 (0,35)	< 60 (0,42)	< 70 (0,49)	< 70 (0,49)	< 85 (0,60)

Support Housing Specifications

Made in the U.S.A.

Support Housing Life millions of screw revolutions	Support Housing Thrust Load Capacity - (Axial)			
	Simple	Fixed (LT)	Fixed (HT)	Rigid
Static	1,675 (760)	2,110 (957)	3,350 (1520)	3,350 (1520)
1	1,675 (760)	2,110 (957)	3,035 (1377)	3,035 (1377)
2	1,365 (619)	1,720 (780)	2,275 (1032)	2,275 (1032)
10	795 (361)	1,050 (476)	1,375 (624)	1,375 (624)
50	465 (211)	585 (265)	820 (372)	820 (372)
100	370 (168)	465 (211)	650 (295)	650 (295)
500	215 (98)	270 (122)	390 (177)	390 (177)

Thrust force applied in either direction

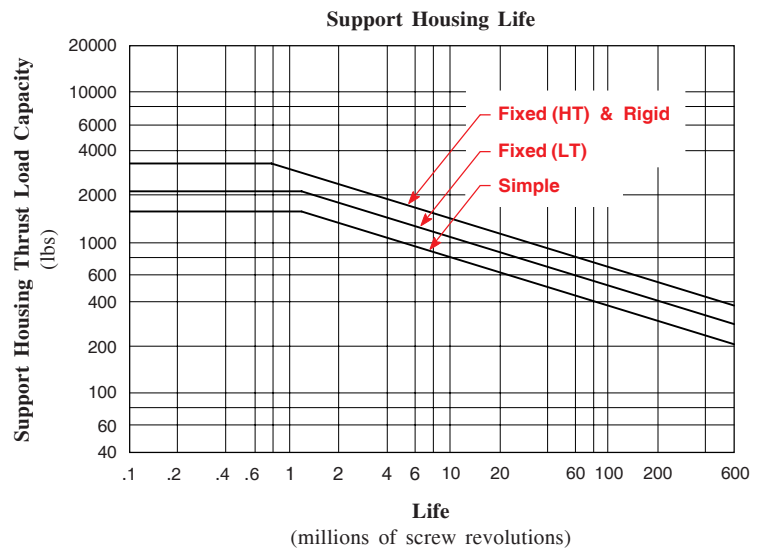
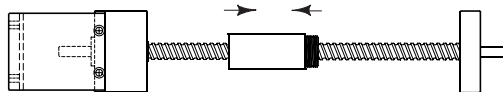

Note: Multiply screw revolutions by the screw lead in order to convert to inches (or mm) traveled by the nut.

Available Configurations

Made in the U.S.A.

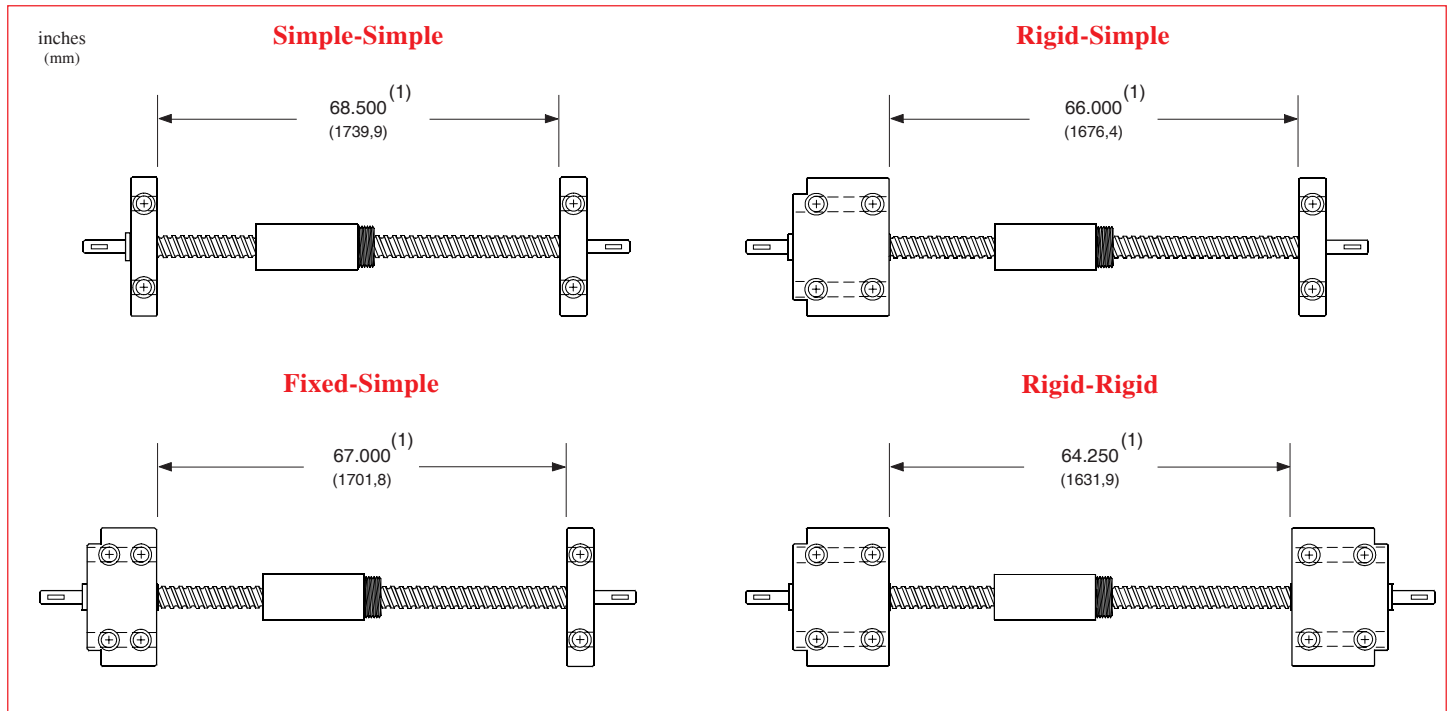

Overall Length Diagram

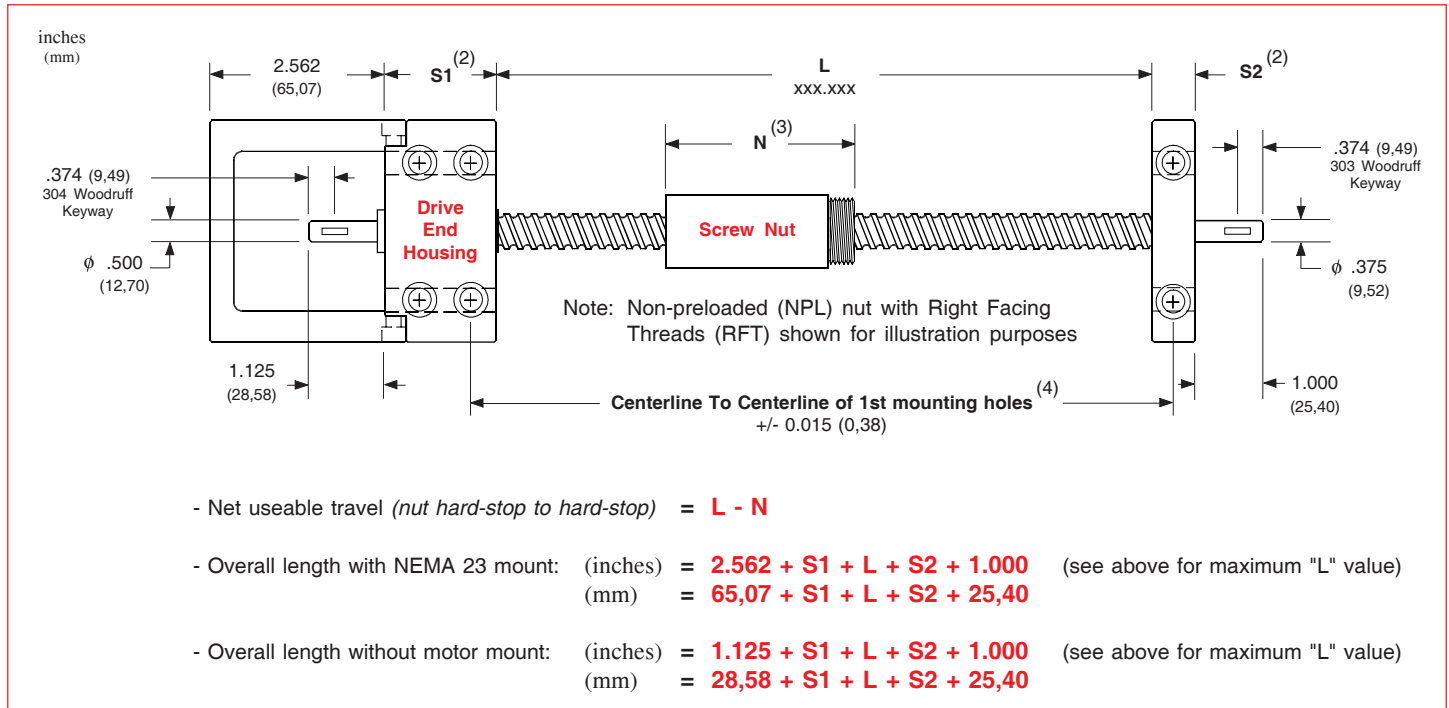

Footnotes:

- (1) Maximum available standard screw thread length for the bearing support housing configuration shown.
- (2) Fixed-simple support configuration shown for reference. See page 45 for length values for simple, fixed, and rigid housings.
- (3) See page 44 for available nut styles. Refer to A1 & A2 values for the nut length.
- (4) Tolerance shown is for base mounted support housings. Tolerance also applies to face mounted support housings.

Specifications subject to change without notice

Performance Charts

Made in the U.S.A.

Simple-Simple

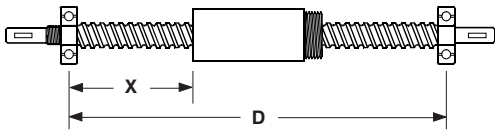

Rigid-Simple

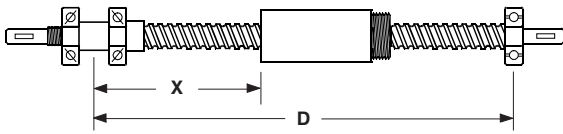

Rigid-Rigid

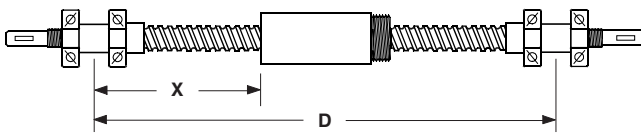

Maximum Compression Load ⁽¹⁾

X inches (mm)	simple-simple		rigid-simple		rigid-rigid	
	lbs	(kgf)	lbs	(kgf)	lbs	(kgf)
20 (508)	4398	(1995)	8796	(3990)	17598	(7982)
40 (1016)	1100	(499)	2200	(998)	4400	(1996)
60 (1524)	489	(222)	978	(444)	1956	(887)

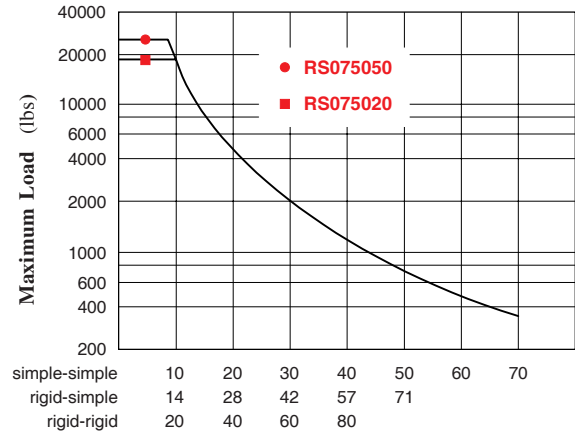

Maximum "X" distance between bearing support and Load (inches)

Maximum Speed ⁽¹⁾

D inches (mm)	simple-simple	rigid-simple	rigid-rigid
	rpm	rpm	rpm
29 (737)	3000	3000	3000
40 (1016)	1640	2410	3000
60 (1524)	725	1070	1625
70 (1778)	535	785	1195

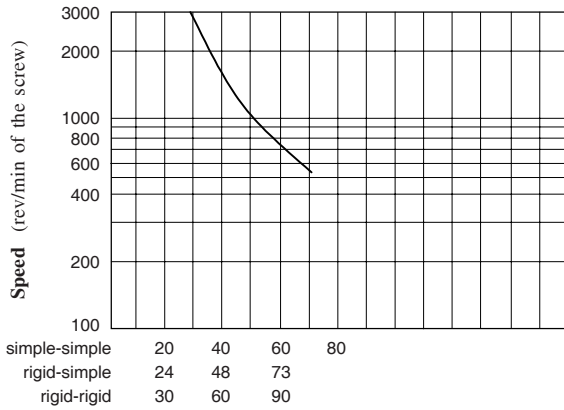

Maximum "D" distance between bearing supports (inches)

Screw Travel Life ⁽²⁾

Life millions of inches (km)	075020		075050		Turcite Nut	
	lbs	(kgf)	lbs	(kgf)	lbs	(kgf)
1 (25)	1900	(862)	3450	(1565)	195	(88)
2 (50)	1540	(698)	2790	(1265)	160	(72)
50 (1270)	540	(245)	990	(450)	55	(29)
100 (2540)	460	(208)	820	(372)	45	(20)

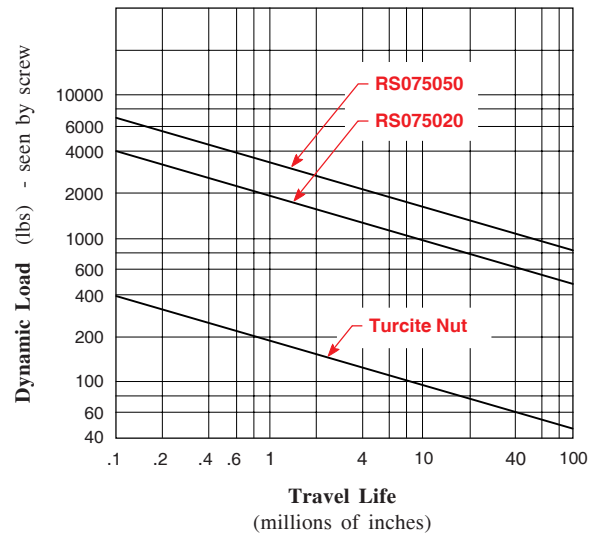

Footnotes:

- Refer to the simple-simple support lengths for fixed-simple configurations. A fixed housing performs like a simple housing for critical speed and compression load specifications. Maximum speeds may not be reached using a Turcite nut due to system friction.
- Multiply life value from chart (or graph) by 0.90 to obtain the life for a preloaded ball nut.

Specifications subject to change without notice

Nut Dimensions

Made in the U.S.A.

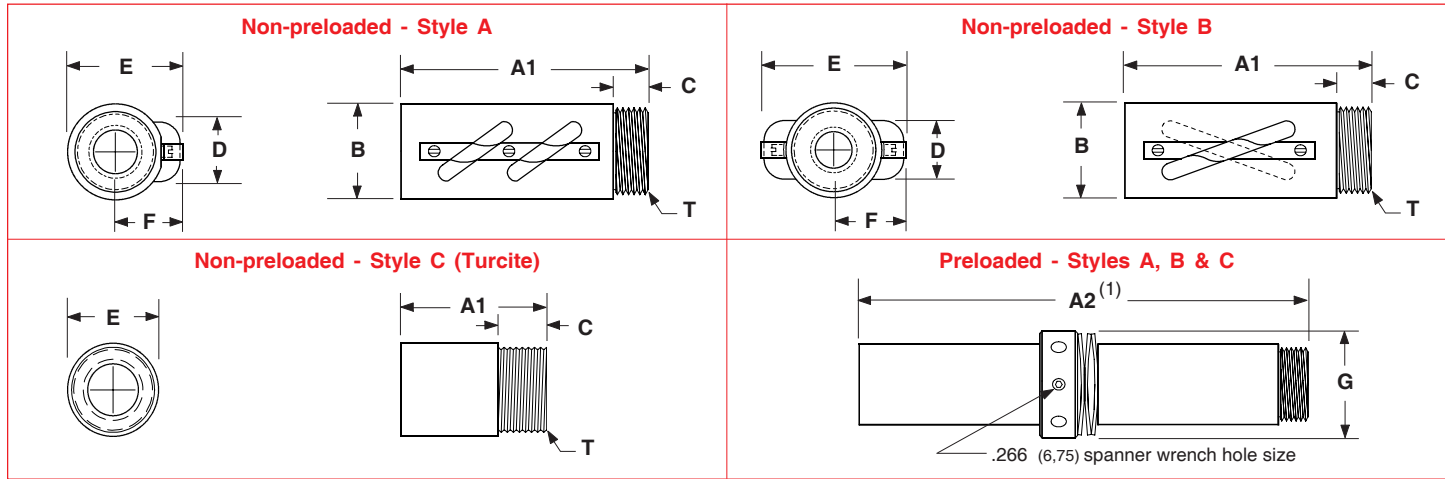

Nut Flange Dimensions

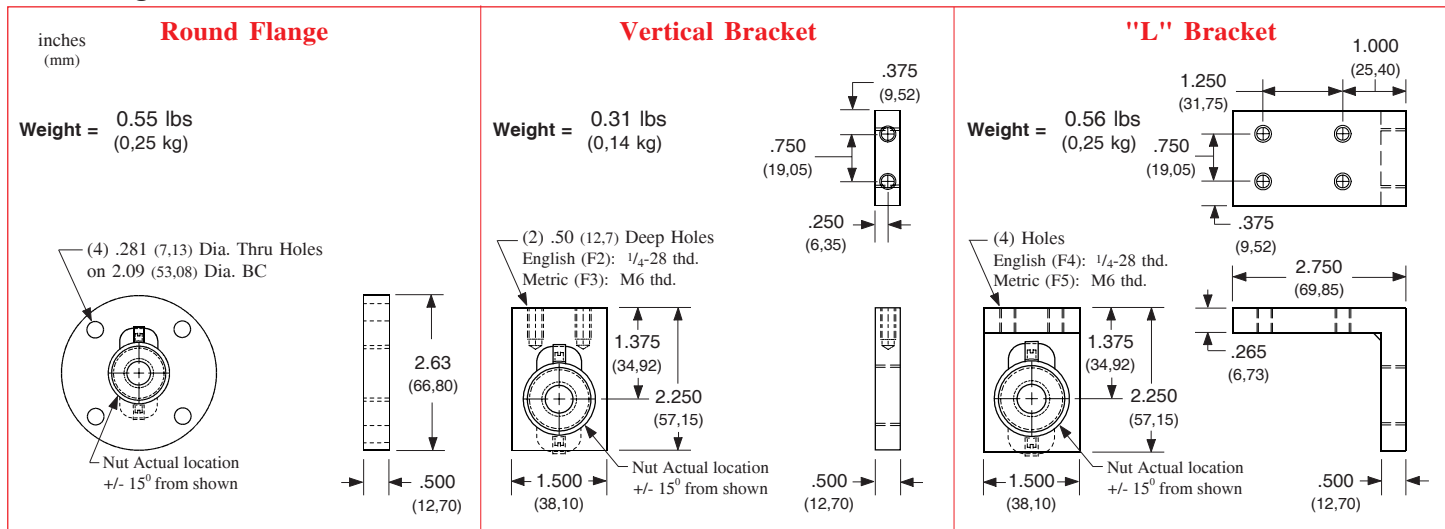

Model Number	Nut Style	Nut Dimensions inches (mm)									Nut Weight ⁽³⁾ lbs (kg)
		A1	A2 ⁽¹⁾	B	C	D	E	F	T - "V" Threads ⁽²⁾	G	
RS075020	A	2.890 (73,40)	6.080 (154,43)	1.317 (33,45)	0.505 (12,82)	0.917 (23,29)	1.521 (38,63)	0.940 (23,87)	1.173 - 18 UNS-2A (29,79 - 18 UNS-2A)	1.670 (42,41)	1.00 (0,45)
RS075050	B	2.940 (74,67)	6.180 (156,97)	1.317 (33,45)	0.505 (12,82)	0.983 (24,96)	1.984 (50,39)	1.060 (26,92)	1 1/4 - 16 UN-2A (31,75 - 16 UN-2A)	1.670 (42,41)	1.00 (0,45)
RS075020	C	1.510 (38,35)	3.520 (89,41)	n/a	0.505 (12,82)	n/a	1.500 (38,10)	n/a	1.173 - 18 UNS-2A (29,79 - 18 UNS-2A)	n/a	0.35 (0,15)
RS075050	C	1.510 (38,35)	3.520 (89,41)	n/a	0.505 (12,82)	n/a	1.500 (38,10)	n/a	1 1/4 - 16 UN-2A (31,75 - 16 UN-2A)	n/a	0.35 (0,15)

Footnotes:

- (1) This is the length for a preloaded nut. Preloaded nut consists of (2) non-preloaded nuts with a locking spanner nut, and belville springs.
- (2) All flange threads are internal (Type 2B) to match the external nut threads.
- (3) Weight of the non-preloaded nut. Multiply value by 2.1 to obtain the weight for the preloaded nut assembly.

Specifications subject to change without notice

Support Housing Dimensions

Made in the U.S.A.

Simple

inches (mm)

.625 (15,87) 2.000 (50,80) (4) .343 (8,71) Dia.Thru Holes

(4) 8-32 x .37 (9,39) Deep on 1.750 (44,45) BC

2.500 (63,50) 1.750 (44,45) 1.250 (31,75)

.375 (9,52) 1.625 (41,27) 3.250 (82,55)

Weight = 1.1 lbs (0,50 kg)

.313 (7,95) (2) .343 (8,71) Dia. Thru Holes, .504 (12,8) Dia. C'Bored x .57 (14,47) Deep

.625 (15,87) .625 (15,87)

Drive End non-Drive End

Fixed

.625 (15,87) 2.000 (50,80) (4) .343 (8,71) Dia.Thru Holes

(4) 8-32 x .37 (9,39) Deep on 1.750 (44,45) BC

2.500 (63,50) 1.750 (44,45) 1.250 (31,75)

.375 (9,52) 1.625 (41,27) 3.250 (82,55) .250 (6,35)

Weight = 2.7 lbs (1,22 kg)

.750 (19,05) .500 (12,70)

(4) .343 (8,71) Dia. Thru Holes, .504 (12,8) Dia. C'Bored x .57 (14,47) Deep

1.125 (28,57)

(2) 10-32 x .43 (10,92) Deep, both sides

.688 (17,47) .125 (3,17) 1.750 (44,45)

Rigid

.625 (15,87) 2.000 (50,80) (4) .343 (8,71) Dia.Thru Holes

(4) 8-32 x .37 (9,39) Deep on 1.750 (44,45) BC

2.500 (63,50) 1.750 (44,45) 1.250 (31,75)

.375 (9,52) 1.625 (41,27) 3.250 (82,55) .250 (6,35)

Weight = 4.0 lbs (1,81 kg)

(4) .343 (8,71) Dia. Thru Holes, .504 (12,8) Dia. C'Bored x .57 (14,47) Deep

1.125 (28,57)

(2) 10-32 x .43 (10,92) Deep, both sides

.688 (17,47) .125 (3,17) 1.750 (44,45) 2.750 (69,85)

NEMA 23 Motor Mount

Weight = 0.9 lbs (0,41 kg)

(4) Holes on 2.625 (66,67) BC Dia. English (M02): #10-24 thd. Metric (M03): M5 thd.

1.502 (38,15) Pilot Dia. TYP

2.340 (59,44)

2.562 (65,07) .313 (7,95)

1.437 (36,50)

2.250 (57,15)

1.125 (28,57)

(2) .221 (5,61) Dia.Thru Holes, .344 (8,73) Dia. C'Bored x .125 (3,17) Deep, both sides

NEMA 34 Motor Mount

Weight = 1.4 lbs (0,64 kg)

(4) Holes on 3.875 (98,42) BC Dia. English (M04): #10-24 thd. Metric (M05): M5 thd.

2.877 (73,07) Pilot Dia. TYP

.063 (1,60)

2.340 (59,44)

.500 (12,70) 2.562 (65,07) .313 (7,95)

1.937 (49,20)

3.375 (85,72)

1.688 (42,88) .438 (11,13)

(2) .221 (5,61) Dia.Thru Holes, .344 (8,73) Dia. C'Bored x .125 (3,17) Deep, both sides

Specifications subject to change without notice

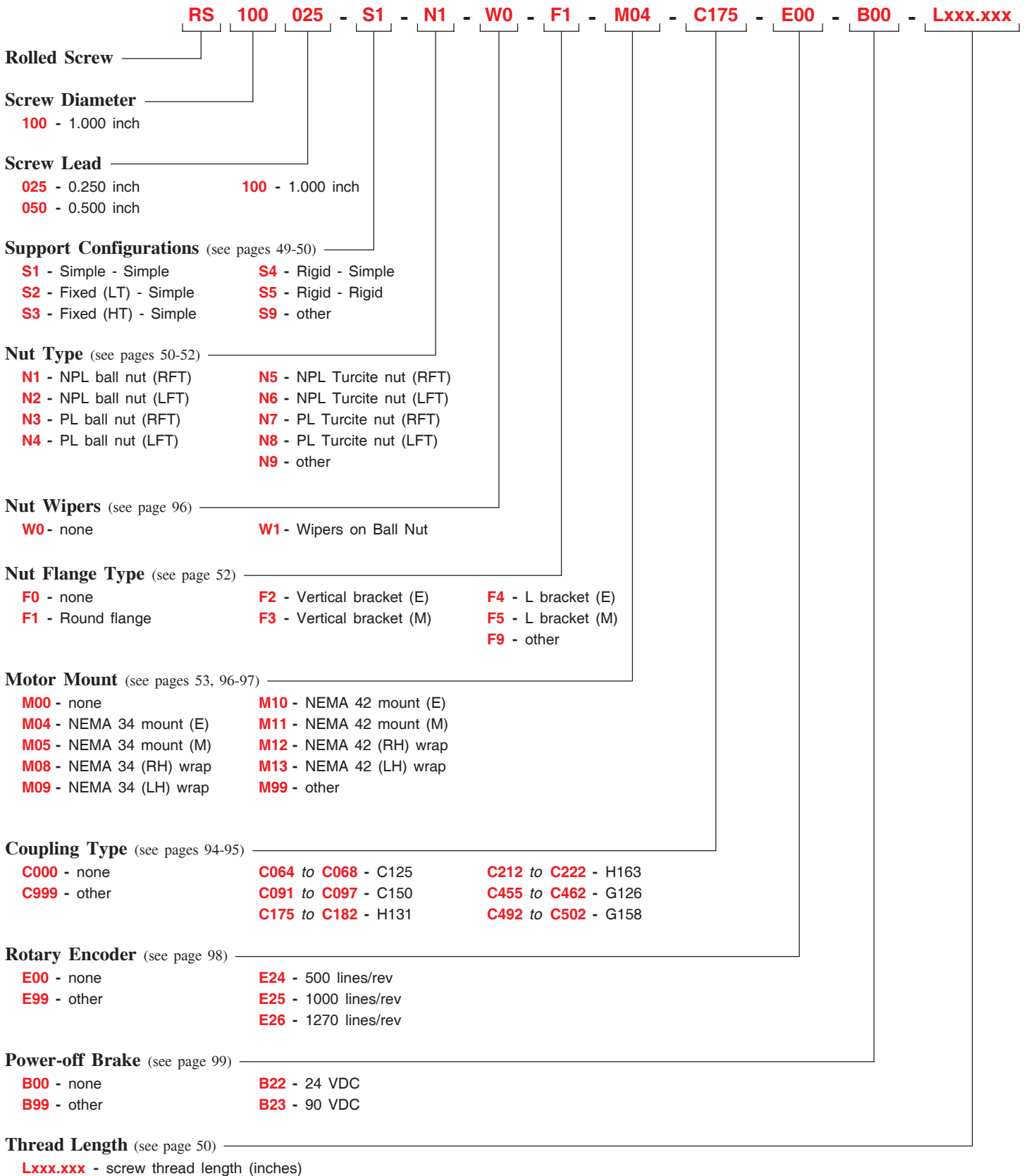

Note: See page 14 for a complete description of the above part number system.

- | | |
|----------------------------|-----------------------------|
| (E) - English Interface | (M) - Metric Interface |
| (LFT) - Left Facing Thread | (NPL) - Non Preloaded |
| (LH) - Left Hand | (PL) - Preloaded |
| (LT) - Low Thrust | (RFT) - Right Facing Thread |
| (HT) - High Thrust | (RH) - Right Hand |

Screw & Nut Specifications

Made in the U.S.A.

Model Number	Nut Type	Diameter inches (mm)	Lead inches (mm)	Root Diameter inches (mm)	Ball Diameter inches (mm)	Number of Circuits	Static Load lbs (kgf)	Dynamic Load ⁽¹⁾ lbs (kgf)
RS100025 1.000 inch dia. 0.250 inch lead	<i>Non-preloaded Ball (N1/N2)</i>	1.000 (25,40)	0.250 (6,35)	0.836 (21,23)	0.156 (3,96)	2	30,750 (13947)	3,350 (1519)
	<i>Preloaded Ball (N3/N4)</i>						30,415 (13796)	3,015 (1367)
	<i>Non-preloaded Turcite (N5/N6)</i>				n/a	n/a	1,500 (680)	195 (88)
	<i>Preloaded Turcite (N7/N8)</i>				n/a	n/a	1,500 (680)	175 (79)
RS100050 1.000 inch dia. 0.500 inch lead	<i>Non-preloaded Ball (N1/N2)</i>	1.000 (25,40)	0.500 (12,70)	0.879 (22,32)	0.156 (3,96)	2	32,300 (14650)	3,950 (1791)
	<i>Preloaded Ball (N3/N4)</i>						31,905 (14471)	3,555 (1612)
	<i>Non-preloaded Turcite (N5/N6)</i>				n/a	n/a	1,500 (680)	195 (88)
	<i>Preloaded Turcite (N7/N8)</i>				n/a	n/a	1,500 (680)	175 (79)
RS100100 1.000 inch dia. 1.000 inch lead	<i>Non-preloaded Ball (N1/N2)</i>	1.000 (25,40)	1.000 (25,40)	0.836 (21,23)	0.156 (3,96)	2	13,750 (6236)	2,250 (1020)
	<i>Preloaded Ball (N3/N4)</i>						13,525 (6134)	2,025 (918)
	<i>Non-preloaded Turcite (N5/N6)</i>				n/a	n/a	1,500 (680)	195 (88)
	<i>Preloaded Turcite (N7/N8)</i>				n/a	n/a	1,500 (680)	175 (79)

Other Specifications

Maximum Acceleration Rate	Ball nut: 772 inches/sec ² (19.6 m/sec ²) Turcite nut: 193 inches/sec ² (4.9 m/sec ²)
Maximum Speed	Ball nut: 3000 rpm Turcite nut: 1500 rpm
Screw Material Screw Extensions	Right Hand Thread, Case Hardened Rc 58 Steel Rolled Ball Screw 605 Woodruff Keyways on Extensions from Support Housings
Screw Maximum Length ⁽²⁾ Screw Weight	144 inches (3657 mm) 2.33 lbs/ft (32,2 kg/cm)
Support Housings Support Housing Features	Steel with Black Oxide Finish, 45° Chamfer x .03 inch (0,76) all Straight Edges Base or Face Mount with Integral Seals
Nut Flanges Nut Flange Features	Steel with Black Oxide Finish English or Metric Load Mounting Interface

Footnotes:

(1) Load based upon 1 million inches (25 Km) of travel life. See page 51 for further travel life ratings.

(2) Maximum stock length (not the maximum thread length with bearing housings). See page 50 for maximum thread lengths for each configuration.

Screw Specifications

Made in the U.S.A.

Model Number	Nut Type	Screw Efficiency %	Lead Error inch/ft (mm/300 mm)	Backlash inches (mm)	Unidirectional Repeatability inches (mm)	Bidirectional Repeatability inches (mm)
RS100025 1.000 inch dia. 0.250 inch lead & RS100050 1.000 inch dia. 0.500 inch lead & RS100100 1.000 inch dia. 1.000 inch lead	<i>Non-preloaded</i> Ball (N1/N2)	90	< 0.009 (0,229)	< 0.009 (0,229)	+/- 0.0002 (0,0050)	+ 0.0002 to - 0.0092 (0,0050) (0,2300)
	<i>Preloaded</i> Ball (N3/N4)					+ 0.0002 to - 0.0002 (0,0050) (0,0050)
	<i>Non-preloaded</i> Turcite (N5/N6)	60	< 0.009 (0,229)	< 0.009 (0,229)	+/- 0.0002 (0,0050)	+ 0.0002 to - 0.0092 (0,0050) (0,2300)
	<i>Preloaded</i> Turcite (N7/N8)					+ 0.0002 to - 0.0002 (0,0050) (0,0050)

Assembly Specifications

Model Number	Nut Type	Breakaway Torque oz-in (N-m)				
		Simple-Simple	Fixed(LT)-Simple	Fixed(HT)-Simple	Rigid-Simple	Rigid-Rigid
RS100025 1.000 inch dia. 0.250 inch lead	<i>Non-preloaded</i> Ball (N1/N2)	< 20 (0,14)	< 25 (0,18)	< 35 (0,25)	< 35 (0,25)	< 50 (0,35)
	<i>Preloaded</i> Ball (N3/N4)	< 35 (0,25)	< 40 (0,28)	< 50 (0,35)	< 50 (0,35)	< 65 (0,45)
	<i>Non-preloaded</i> Turcite (N5/N6)	< 30 (0,21)	< 35 (0,25)	< 45 (0,32)	< 45 (0,32)	< 60 (0,42)
	<i>Preloaded</i> Turcite (N7/N8)	< 55 (0,39)	< 60 (0,42)	< 70 (0,49)	< 70 (0,49)	< 85 (0,60)
RS100050 1.000 inch dia. 0.500 inch lead	<i>Non-preloaded</i> Ball (N1/N2)	< 25 (0,18)	< 30 (0,21)	< 50 (0,35)	< 50 (0,35)	< 65 (0,45)
	<i>Preloaded</i> Ball (N3/N4)	< 45 (0,32)	< 50 (0,35)	< 70 (0,49)	< 70 (0,49)	< 80 (0,56)
	<i>Non-preloaded</i> Turcite (N5/N6)	< 40 (0,28)	< 45 (0,32)	< 65 (0,45)	< 65 (0,45)	< 80 (0,56)
	<i>Preloaded</i> Turcite (N7/N8)	< 75 (0,53)	< 80 (0,56)	< 100 (0,70)	< 100 (0,70)	< 115 (0,81)
RS100100 1.000 inch dia. 1.000 inch lead	<i>Non-preloaded</i> Ball (N1/N2)	< 30 (0,21)	< 35 (0,25)	< 55 (0,39)	< 55 (0,39)	< 75 (0,53)
	<i>Preloaded</i> Ball (N3/N4)	< 55 (0,39)	< 60 (0,42)	< 80 (0,56)	< 80 (0,56)	< 100 (0,71)
	<i>Non-preloaded</i> Turcite (N5/N6)	< 45 (0,32)	< 50 (0,35)	< 70 (0,49)	< 70 (0,49)	< 90 (0,64)
	<i>Preloaded</i> Turcite (N7/N8)	< 85 (0,60)	< 90 (0,64)	< 110 (0,79)	< 110 (0,79)	< 130 (0,92)

Specifications subject to change without notice

Support Housing Specifications

Made in the U.S.A.

Support Housing Life millions of screw revolutions	Support Housing Thrust Load Capacity - (Axial)			
	Simple	Fixed (LT)	Fixed (HT)	Rigid
Static	2,880 (1306)	3,630 (1646)	6,615 (3000)	6,615 (3000)
1	2,880 (1306)	3,630 (1646)	5,240 (2377)	5,240 (2377)
2	2,285 (1036)	2,880 (1306)	4,160 (1887)	4,160 (1887)
10	1,335 (606)	1,685 (764)	2,430 (1102)	2,430 (1102)
50	805 (365)	990 (449)	1,420 (644)	1,420 (644)
100	620 (281)	795 (360)	1,130 (512)	1,130 (512)
500	375 (170)	455 (206)	660 (299)	660 (299)

Thrust force applied in either direction

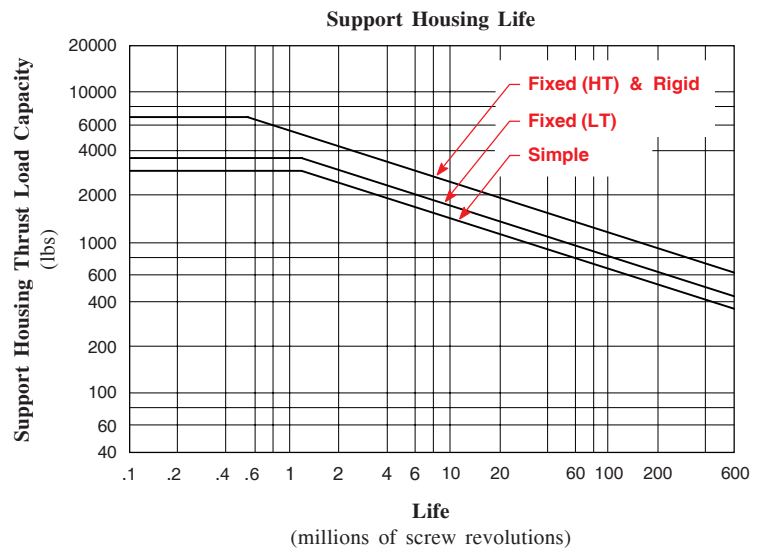
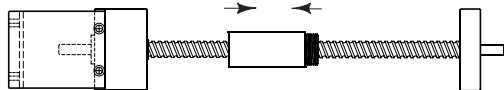

Note: Multiply screw revolutions by the screw lead in order to convert to inches (or mm) traveled by the nut.

Available Configurations

Made in the U.S.A.

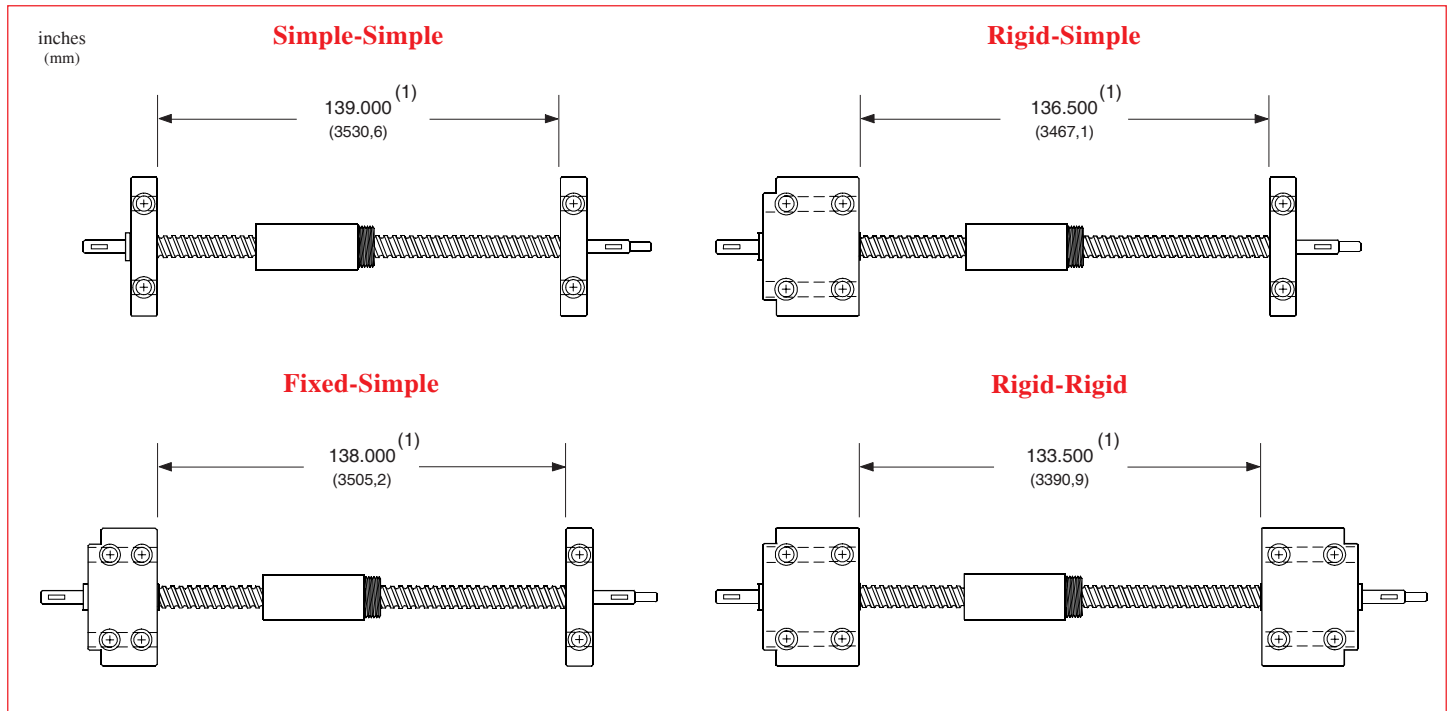

Overall Length Diagram

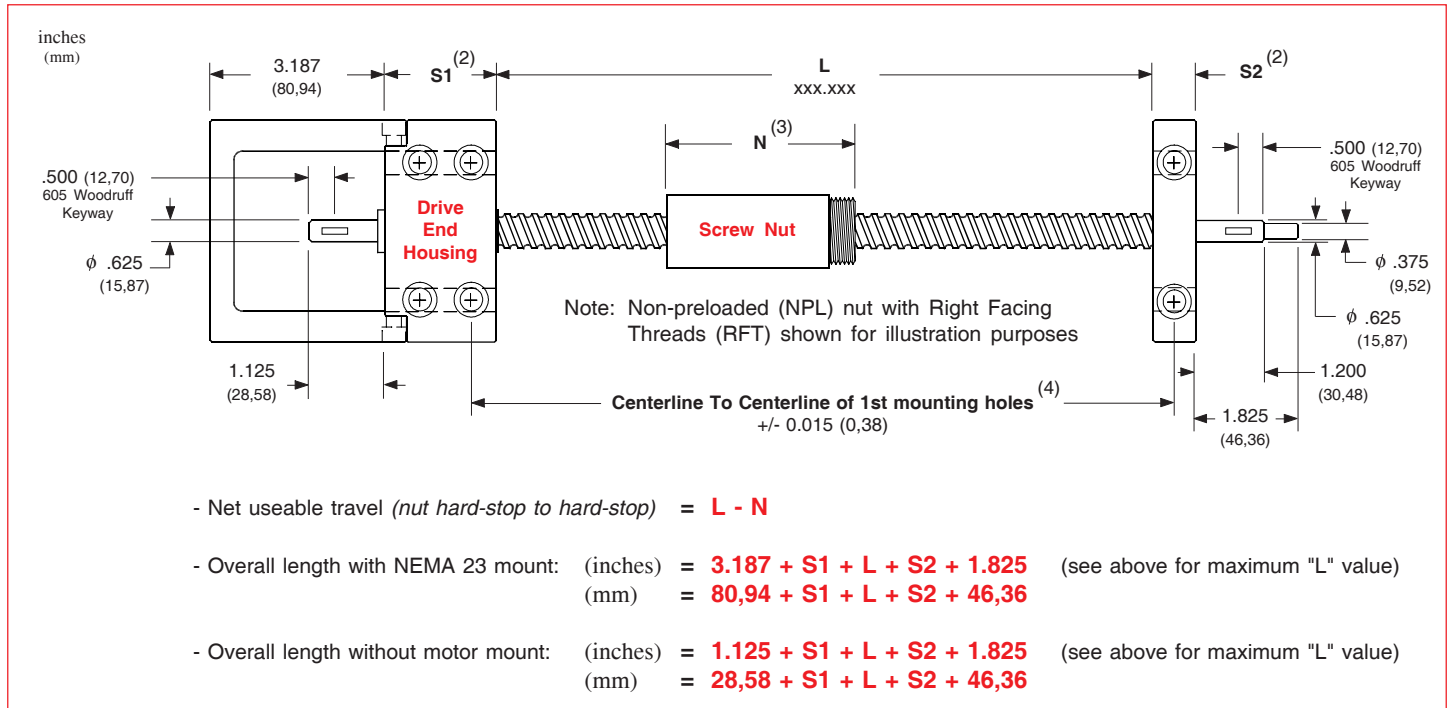

Footnotes:

- (1) Maximum available standard screw thread length for the bearing support housing configuration shown.
- (2) Fixed-simple support configuration shown for reference. See page 53 for length values for simple, fixed, and rigid housings.
- (3) See page 52 for available nut styles. Refer to A1 & A2 values for the nut length.
- (4) Tolerance shown is for base mounted support housings. Tolerance also applies to face mounted support housings.

Performance Charts

Made in the U.S.A.

Simple-Simple

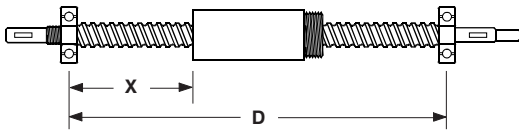

Rigid-Simple

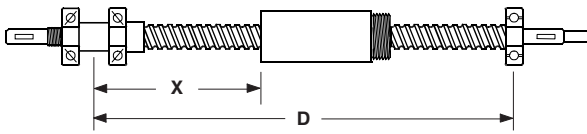

Rigid-Rigid

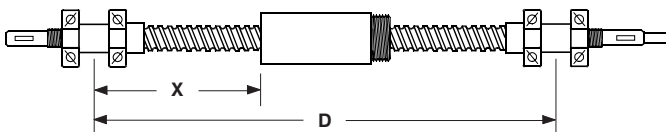

Maximum Compression Load ⁽¹⁾

X inches	(mm)	simple-simple		rigid-simple		rigid-rigid	
		lbs	(kgf)	lbs	(kgf)	lbs	(kgf)
40	(1016)	3430	(1556)	6860	(3112)	13720	(6223)
80	(2032)	855	(388)	1710	(776)	3420	(1551)
120	(3048)	380	(172)	760	(345)	1520	(690)

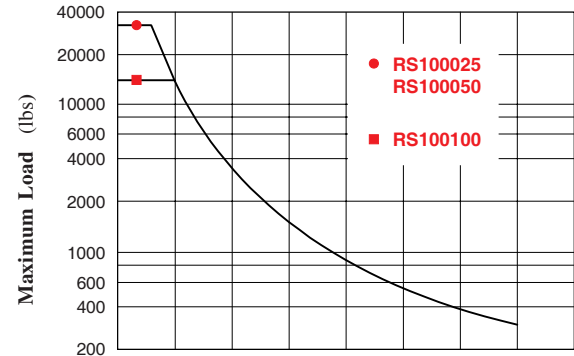

simple-simple	20	40	60	80	100	120	140
rigid-simple	28	57	85	113	141		
rigid-rigid	40	80	120	160			

Maximum "X" distance between bearing support and Load (inches)

Maximum Speed ⁽¹⁾

D inches	(mm)	simple-simple	rigid-simple	rigid-rigid
		rpm	rpm	rpm
34	(864)	3000	3000	3000
60	(1524)	970	1425	2160
100	(2540)	345	510	775
140	(3556)	175	260	395

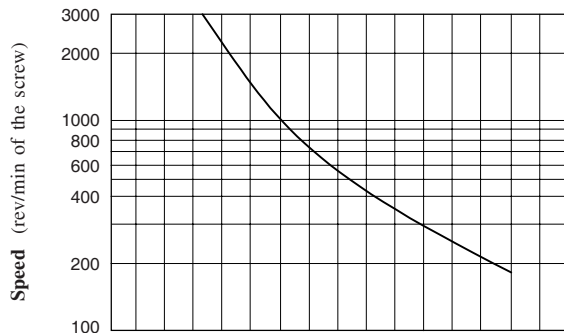

simple-simple	20	40	60	80	100	120	140
rigid-simple	24	48	73	97	121	145	
rigid-rigid	30	60	90	119	149		

Maximum "D" distance between bearing supports (inches)

Screw Travel Life ⁽²⁾

Life millions of inches (km)	100025		100050		100100		Turcite Nut	
	lbs	(kgf)	lbs	(kgf)	lbs	(kgf)	lbs	(kgf)
1	(25)	3350 (1520)	3950 (1792)	2250 (1020)	195	(88)		
2	(50)	2710 (1229)	3200 (1451)	1820 (825)	160	(72)		
50	(1270)	990 (449)	1100 (499)	670 (304)	55	(29)		
100	(2540)	810 (367)	970 (440)	560 (254)	45	(20)		

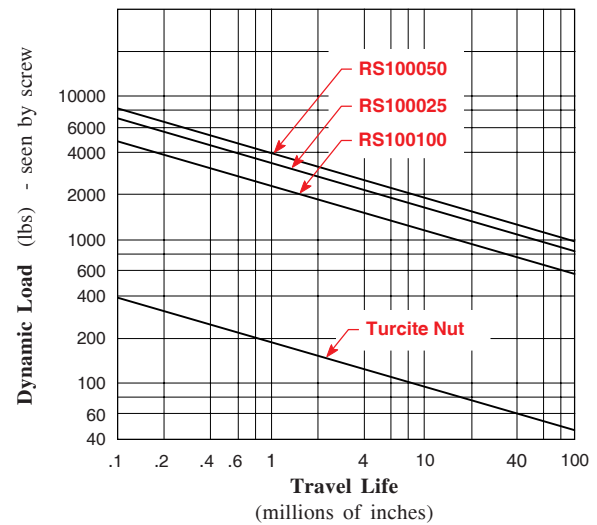

Footnotes:

- (1) Refer to the simple-simple support lengths for fixed-simple configurations. A fixed housing performs like a simple housing for critical speed and compression load specifications. Maximum speeds may not be reached using a Turcite nut due to system friction.
- (2) Multiply life value from chart (or graph) by 0.90 to obtain the life for a preloaded ball nut.

Nut Dimensions

Made in the U.S.A.

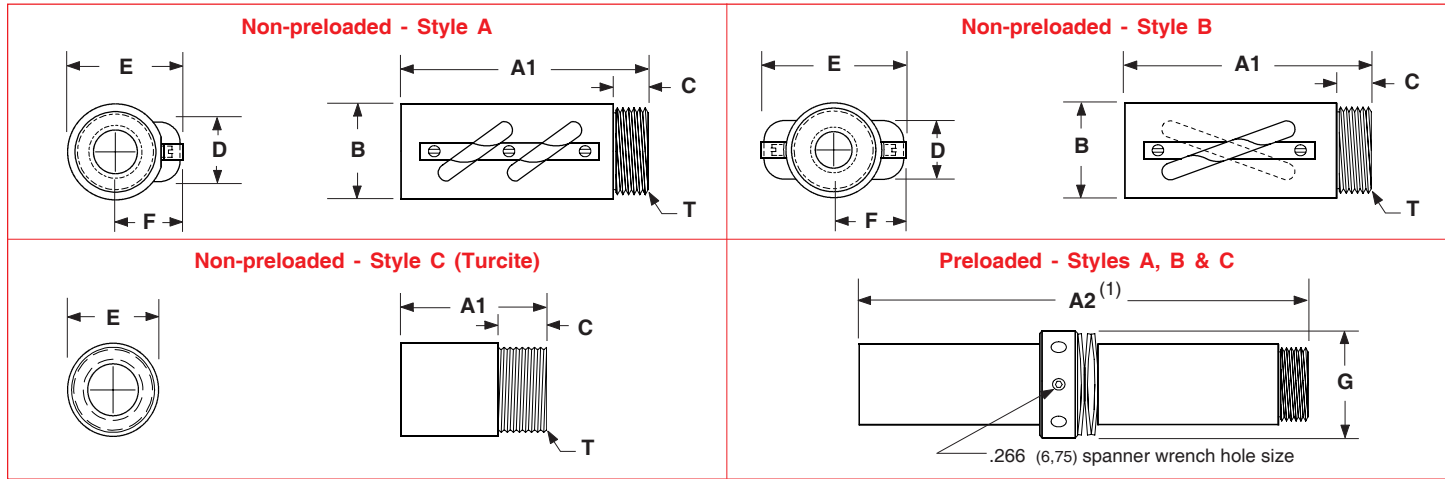

Nut Flange Dimensions

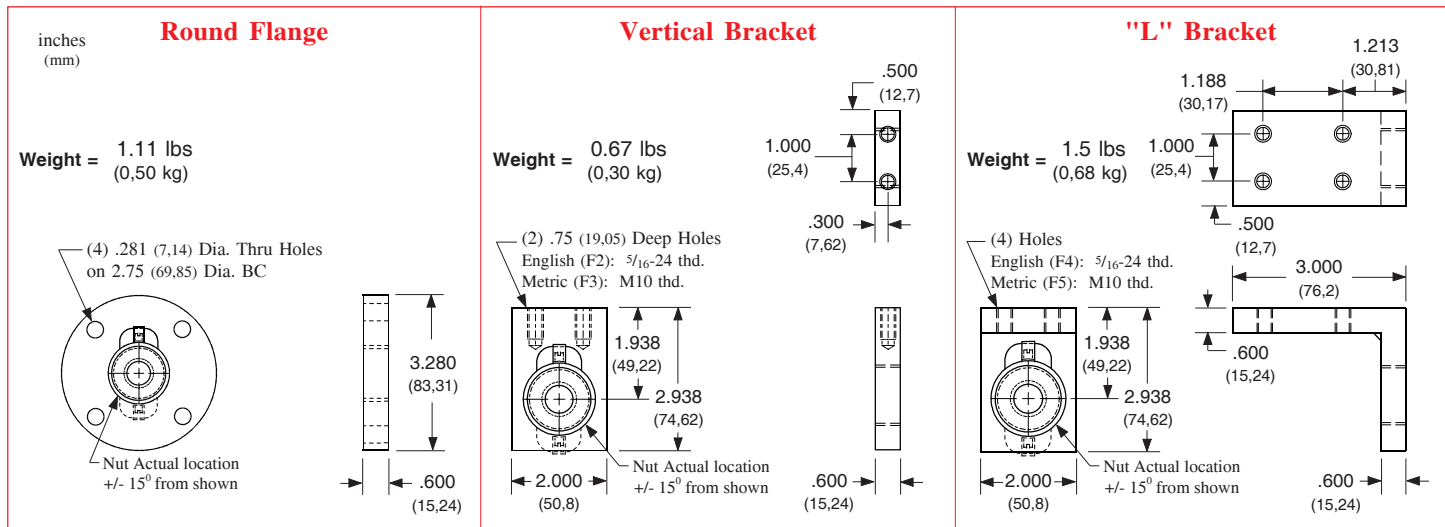

Model Number	Nut Style	Nut Dimensions inches (mm)									Nut ⁽³⁾ Weight lbs (kg)
		A1	A2 ⁽¹⁾	B	C	D	E	F	T - "V" Threads ⁽²⁾	G	
RS100025	A	3.140 (79,76)	6.640 (168,66)	1.692 (42,98)	0.630 (16,00)	1.191 (30,25)	1.882 (47,80)	1.120 (28,45)	1 9/16 - 18 UNEF-2A (39,68 - 18 UNEF-2A)	2.070 (52,57)	1.25 (0,56)
RS100050	B	3.130 (79,50)	6.640 (168,66)	1.692 (42,98)	0.630 (16,00)	1.191 (30,25)	1.882 (47,80)	1.120 (28,45)	1 9/16 - 18 UNEF-2A (39,68 - 18 UNEF-2A)	2.070 (52,57)	1.25 (0,56)
RS100100	B	3.100 (78,74)	6.520 (165,61)	1.692 (42,98)	0.605 (15,37)	1.200 (30,48)	2.172 (55,17)	1.170 (29,72)	1 9/16 - 18 UNEF-2A (39,68 - 18 UNEF-2A)	2.070 (52,57)	1.25 (0,56)
RS100025	C	1.500 (38,10)	3.500 (88,90)	n/a	0.600 (15,24)	n/a	1.750 (44,45)	n/a	1 9/16 - 18 UNEF-2A (39,68 - 18 UNEF-2A)	n/a	0.35 (0,15)
RS100050	C	1.500 (38,10)	3.500 (88,90)	n/a	0.600 (15,24)	n/a	1.750 (44,45)	n/a	1 9/16 - 18 UNEF-2A (39,68 - 18 UNEF-2A)	n/a	0.35 (0,15)
RS100100	C	1.500 (38,10)	3.500 (88,90)	n/a	0.600 (15,24)	n/a	1.750 (44,45)	n/a	1 9/16 - 18 UNEF-2A (39,68 - 18 UNEF-2A)	n/a	0.35 (0,15)

Footnotes:

- (1) This is the length for a preloaded nut. Preloaded nut consists of (2) non-preloaded nuts with a locking spanner nut, and belville springs.
- (2) All flange threads are internal (Type 2B) to match the external nut threads.
- (3) Weight of the non-preloaded nut. Multiply value by 2.1 to obtain the weight for the preloaded nut assembly.

Specifications subject to change without notice

Support Housing Dimensions

Made in the U.S.A.

Simple

Weight = 2.5 lbs (1,14 kg)

Drive End
non-Drive End

Fixed

Weight = 6.6 lbs (2,99 kg)

Rigid

Weight = 11.8 lbs (5,35 kg)

NEMA 34 Motor Mount

Weight = 2.0 lbs (0,91 kg)

NEMA 42 Motor Mount

Weight = 3.2 lbs (1,45 kg)

Specifications subject to change without notice

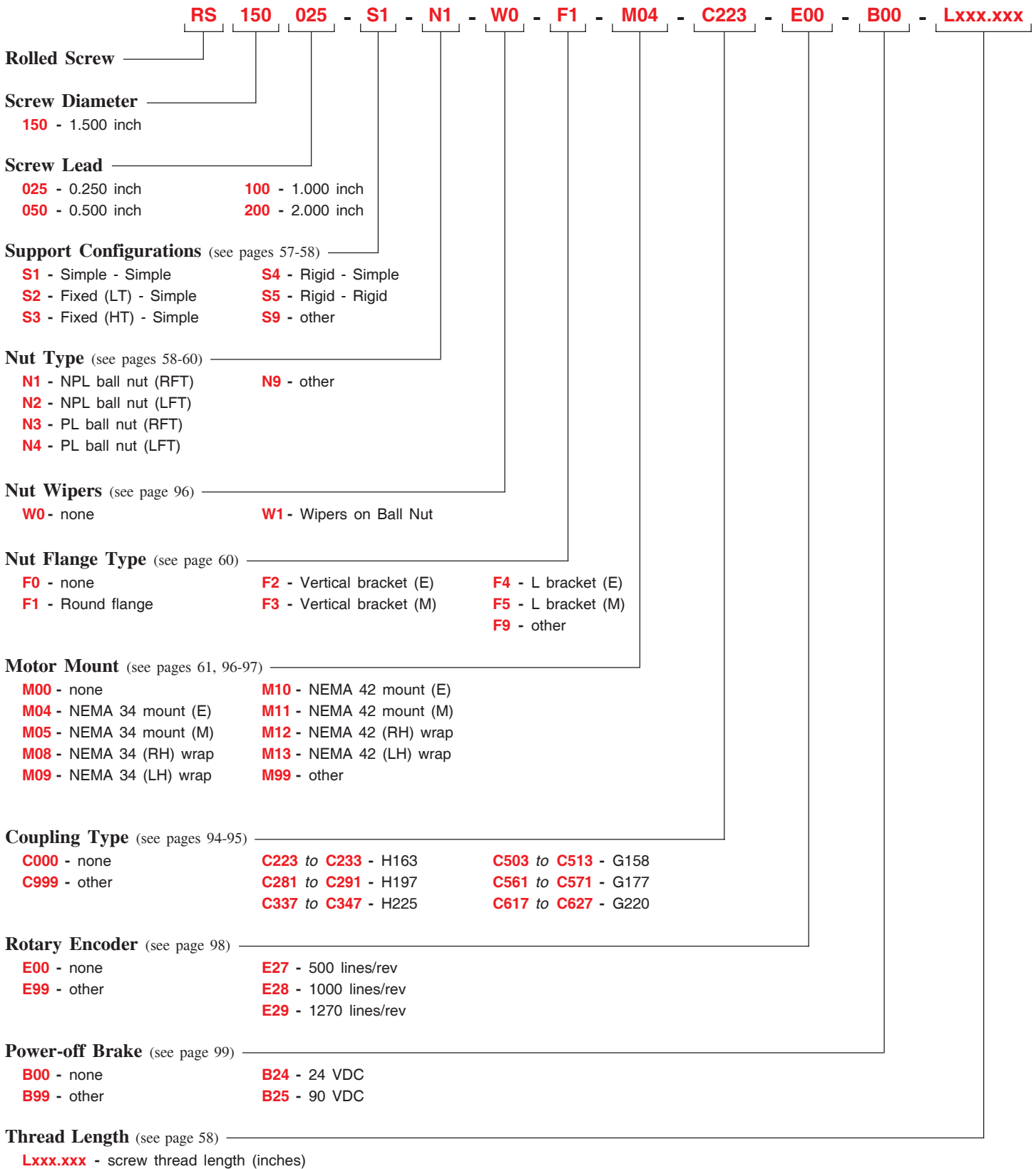

Note: See page 14 for a complete description of the above part number system.

- | | |
|----------------------------|-----------------------------|
| (E) - English Interface | (M) - Metric Interface |
| (LFT) - Left Facing Thread | (NPL) - Non Preloaded |
| (LH) - Left Hand | (PL) - Preloaded |
| (LT) - Low Thrust | (RFT) - Right Facing Thread |
| (HT) - High Thrust | (RH) - Right Hand |

Screw & Nut Specifications

Made in the U.S.A.

Model Number	Nut Type	Diameter inches (mm)	Lead inches (mm)	Root Diameter inches (mm)	Ball Diameter inches (mm)	Number of Circuits	Static Load lbs (kgf)	Dynamic Load ⁽¹⁾ lbs (kgf)
RS150025 1.500 inch dia. 0.250 inch lead	<i>Non-preloaded</i> Ball (N1/N2)	1.500 (38,10)	0.250 (6,35)	1.379 (35,03)	0.156 (3,96)	2	47,450 (21523)	4,050 (1837)
	<i>Preloaded</i> Ball (N3/N4)						47,045 (21339)	3,645 (1653)
RS150050 1.500 inch dia. 0.500 inch lead	<i>Non-preloaded</i> Ball (N1/N2)	1.500 (38,10)	0.500 (12,70)	1.265 (32,13)	0.312 (7,92)	2	102,300 (46402)	12,900 (5851)
	<i>Preloaded</i> Ball (N3/N4)						101,010 (45817)	11,610 (5266)
RS150100 1.500 inch dia. 1.000 inch lead	<i>Non-preloaded</i> Ball (N1/N2)	1.500 (38,10)	1.000 (25,40)	1.143 (29,03)	0.344 (8,73)	2	47,800 (21682)	8,250 (3742)
	<i>Preloaded</i> Ball (N3/N4)						46,975 (21307)	7,425 (3368)
RS150200 1.500 inch dia. 2.000 inch lead	<i>Non-preloaded</i> Ball (N1/N2)	1.500 (38,10)	2.000 (50,80)	1.210 (30,73)	0.281 (7,13)	2	31,250 (14175)	7,600 (3447)
	<i>Preloaded</i> Ball (N3/N4)						28,240 (12809)	6,840 (3103)

Other Specifications

Maximum Acceleration Rate	Ball nut: 772 inches/sec ² (19.6 m/sec ²)
Maximum Speed	Ball nut: 3000 rpm
Screw Material	Right Hand Thread, Case Hardened Rc 58 Steel Rolled Ball Screw
Screw Extensions	605 Woodruff Keyways on Extensions from Support Housings
Screw Maximum Length ⁽²⁾	144 inches (3657 mm)
Screw Weight	5.58 lbs/ft (77,1 kg/cm)
Support Housings	Steel with Black Oxide Finish, 45° Chamfer x .03 inch (0,76) all Straight Edges
Support Housing Features	Base or Face Mount with Integral Seals
Nut Flanges	Steel with Black Oxide Finish
Nut Flange Features	English or Metric Load Mounting Interface

Footnotes:

- (1) Load based upon 1 million inches (25 Km) of travel life. See page 59 for further travel life ratings.
 (2) Maximum stock length (not the maximum thread length with bearing housings). See page 58 for maximum thread lengths for each configuration.

Screw Specifications

Made in the U.S.A.

Model Number	Nut Type	Screw Efficiency %	Lead Error inch/ft (mm/300 mm)	Backlash inches (mm)	Unidirectional Repeatability inches (mm)	Bidirectional Repeatability inches (mm)
RS150025 1.500 inch dia. 0.250 inch lead & RS150050 1.500 inch dia. 0.500 inch lead & RS150100 1.500 inch dia. 1.000 inch lead & RS150200 1.500 inch dia. 2.000 inch lead	<i>Non-preloaded</i> Ball (N1/N2)	90	< 0.009 (0,229)	< 0.013 (0,330)	+/- 0.0002 (0,0050)	+ 0.0002 to - 0.0132 (0,0050) (0,3353)
	<i>Preloaded</i> Ball (N3/N4)	90	< 0.009 (0,229)	0	+/- 0.0002 (0,0050)	+ 0.0002 to - 0.0002 (0,0050) (0,0050)

Assembly Specifications

Model Number	Nut Type	Breakaway Torque oz-in (N-m)				
		Simple-Simple	Fixed(LT)-Simple	Fixed(HT)-Simple	Rigid-Simple	Rigid-Rigid
RS150025 1.500 inch dia. 0.250 inch lead	<i>Non-preloaded</i> Ball (N1/N2)	< 35 (0,25)	< 50 (0,35)	< 70 (0,49)	< 70 (0,49)	< 90 (0,64)
	<i>Preloaded</i> Ball (N3/N4)	< 70 (0,49)	< 85 (0,60)	< 105 (0,74)	< 105 (0,74)	< 125 (0,88)
RS150050 1.500 inch dia. 0.500 inch lead	<i>Non-preloaded</i> Ball (N1/N2)	< 40 (0,28)	< 55 (0,39)	< 75 (0,53)	< 75 (0,53)	< 95 (0,67)
	<i>Preloaded</i> Ball (N3/N4)	< 80 (0,56)	< 95 (0,67)	< 115 (0,81)	< 115 (0,81)	< 135 (0,95)
RS150100 1.500 inch dia. 1.000 inch lead	<i>Non-preloaded</i> Ball (N1/N2)	< 45 (0,32)	< 60 (0,42)	< 80 (0,56)	< 80 (0,56)	< 100 (0,71)
	<i>Preloaded</i> Ball (N3/N4)	< 90 (0,64)	< 105 (0,74)	< 125 (0,88)	< 125 (0,88)	< 145 (1,02)
RS150200 1.500 inch dia. 2.000 inch lead	<i>Non-preloaded</i> Ball (N1/N2)	< 60 (0,42)	< 75 (0,53)	< 95 (0,67)	< 95 (0,67)	< 115 (0,81)
	<i>Preloaded</i> Ball (N3/N4)	< 120 (0,85)	< 135 (0,95)	< 155 (1,09)	< 155 (1,09)	< 175 (1,24)

Support Housing Specifications

Made in the U.S.A.

Support Housing Life millions of screw revolutions	Support Housing Thrust Load Capacity - (Axial)			
	Simple	Fixed (LT)	Fixed (HT)	Rigid
Static	4,380 (1987)	5,520 (2504)	11,700 (5307)	11,700 (5307)
1	4,380 (1987)	5,520 (2504)	8,060 (3656)	8,060 (3656)
2	3,475 (1576)	4,380 (1987)	6,400 (2903)	6,400 (2903)
10	2,035 (923)	2,565 (1163)	3,740 (1696)	3,740 (1696)
50	1,190 (540)	1,500 (680)	2,185 (991)	2,185 (991)
100	945 (429)	1,190 (540)	1,735 (787)	1,735 (787)
500	550 (249)	695 (315)	1,015 (460)	1,015 (460)

Thrust force applied in either direction

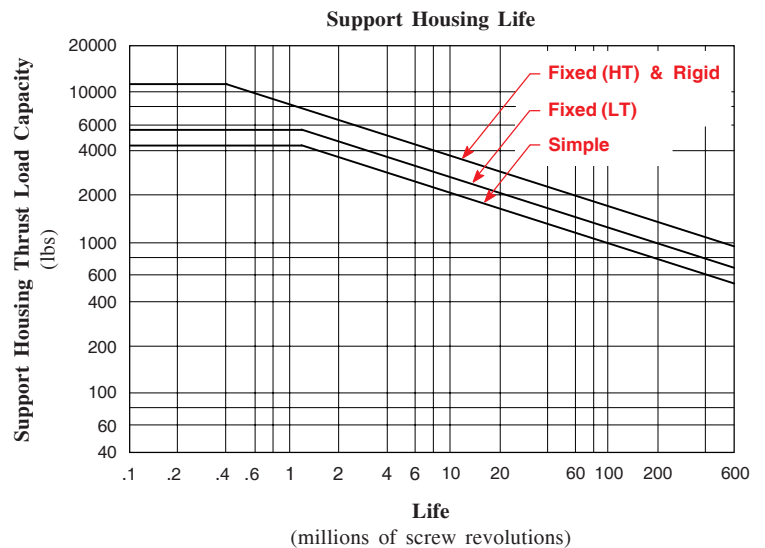
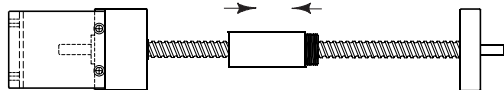

Note: Multiply screw revolutions by the screw lead in order to convert to inches (or mm) traveled by the nut.

Available Configurations

Made in the U.S.A.

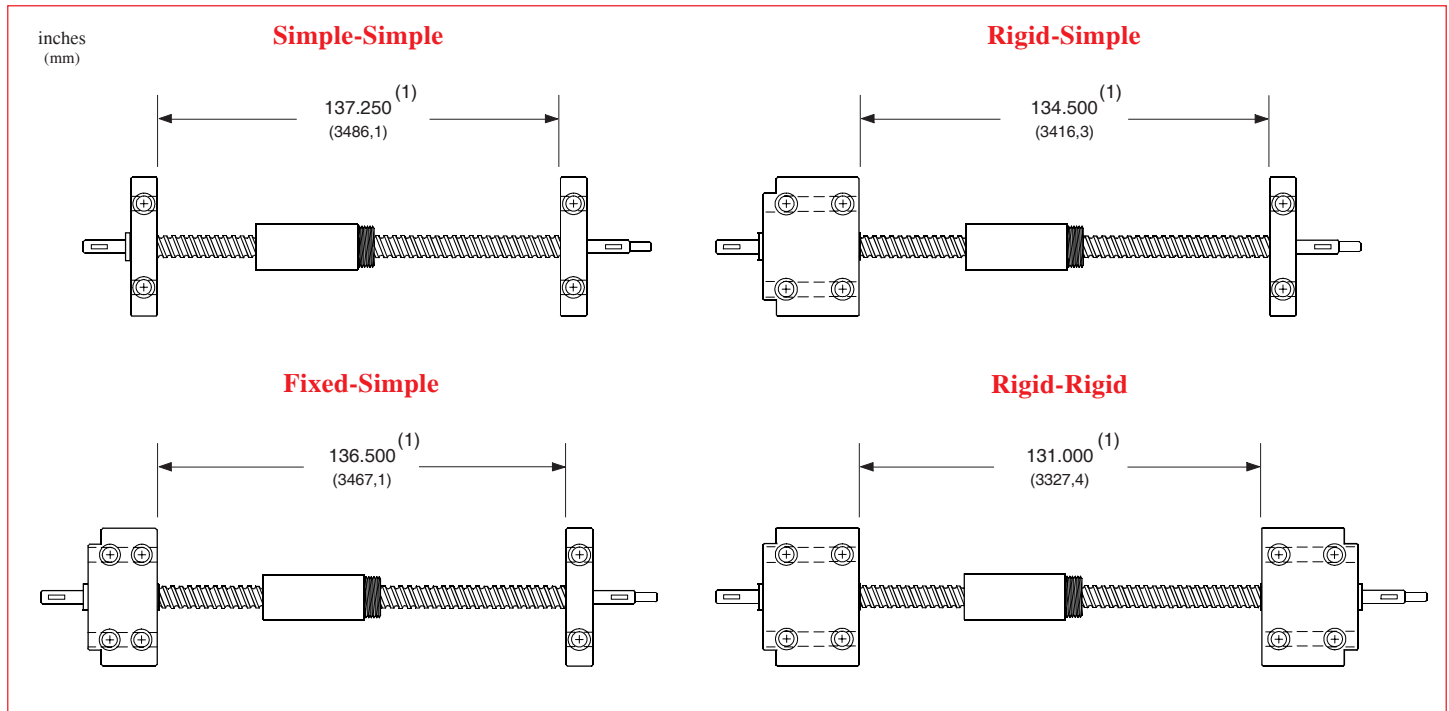

Overall Length Diagram

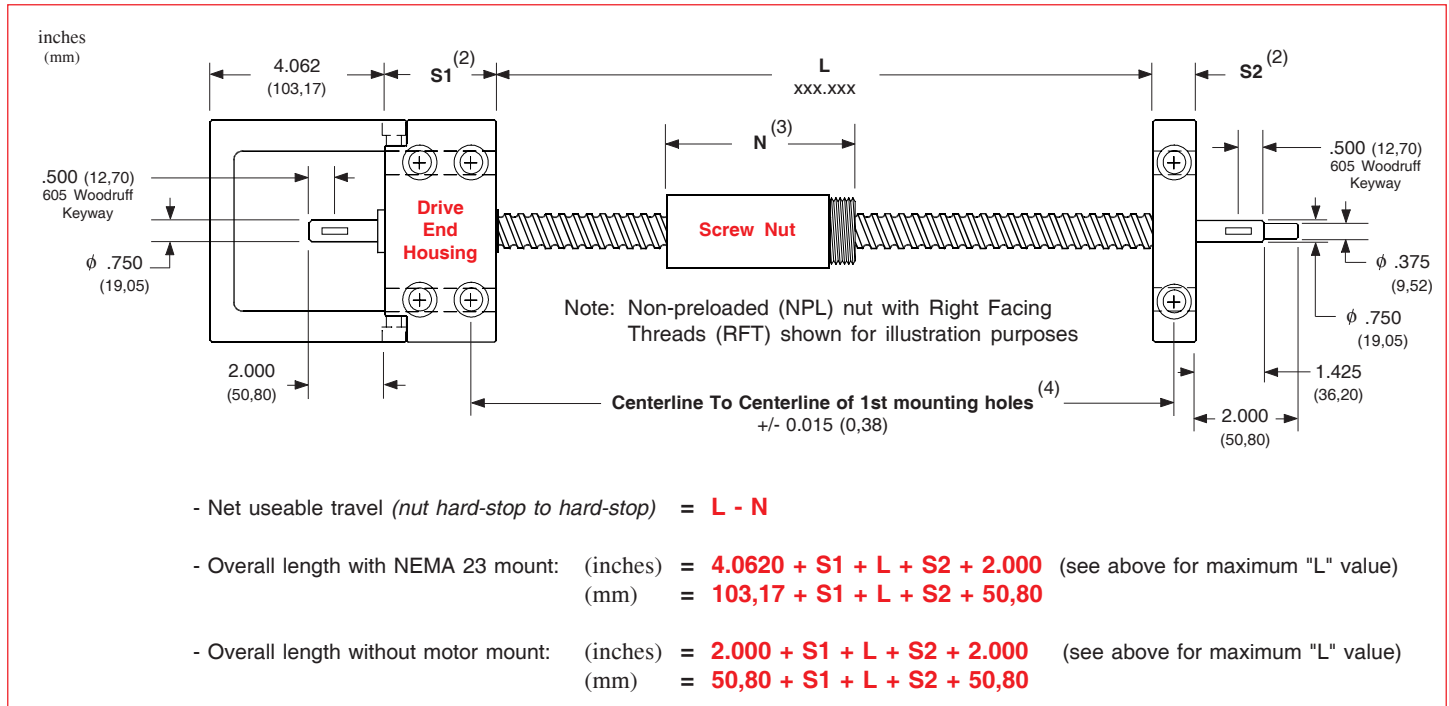

Footnotes:

- (1) Maximum available standard screw thread length for the bearing support housing configuration shown.
- (2) Fixed-simple support configuration shown for reference. See page 61 for length values for simple, fixed, and rigid housings.
- (3) See page 60 for available nut styles. Refer to A1 & A2 values for the nut length.
- (4) Tolerance shown is for base mounted support housings. Tolerance also applies to face mounted support housings.

Performance Charts

Made in the U.S.A.

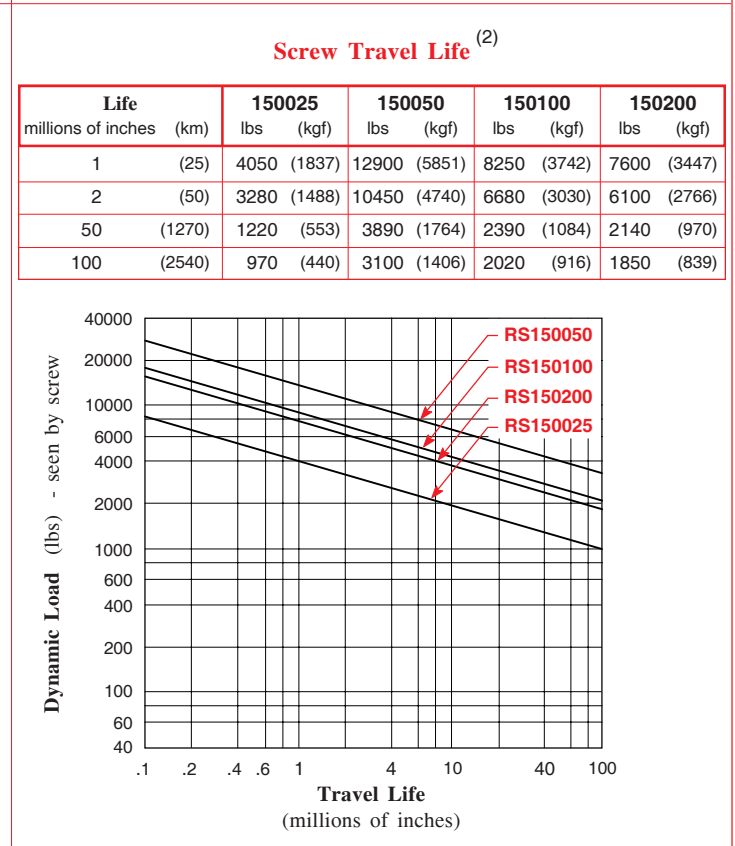
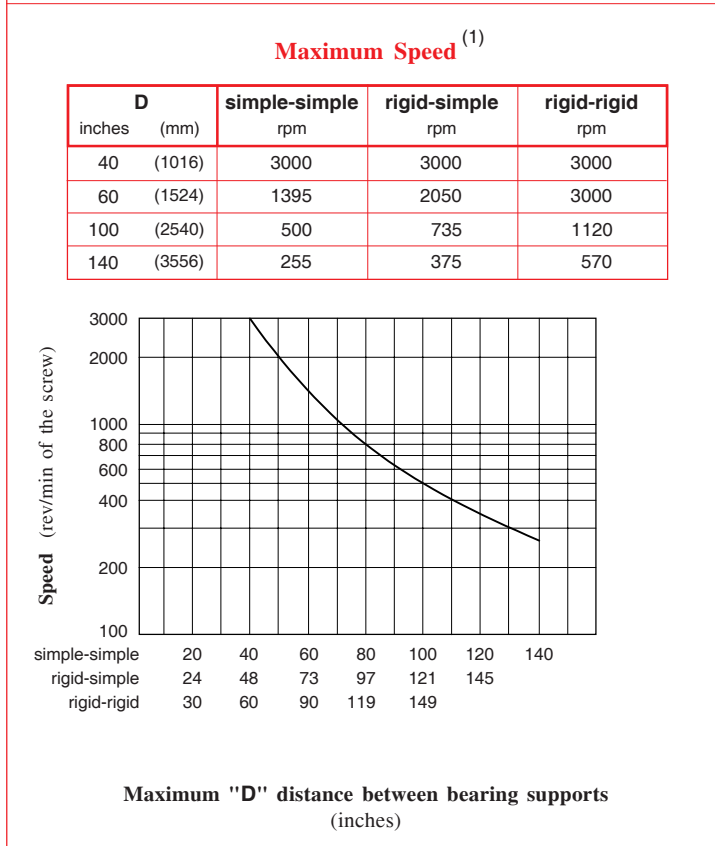
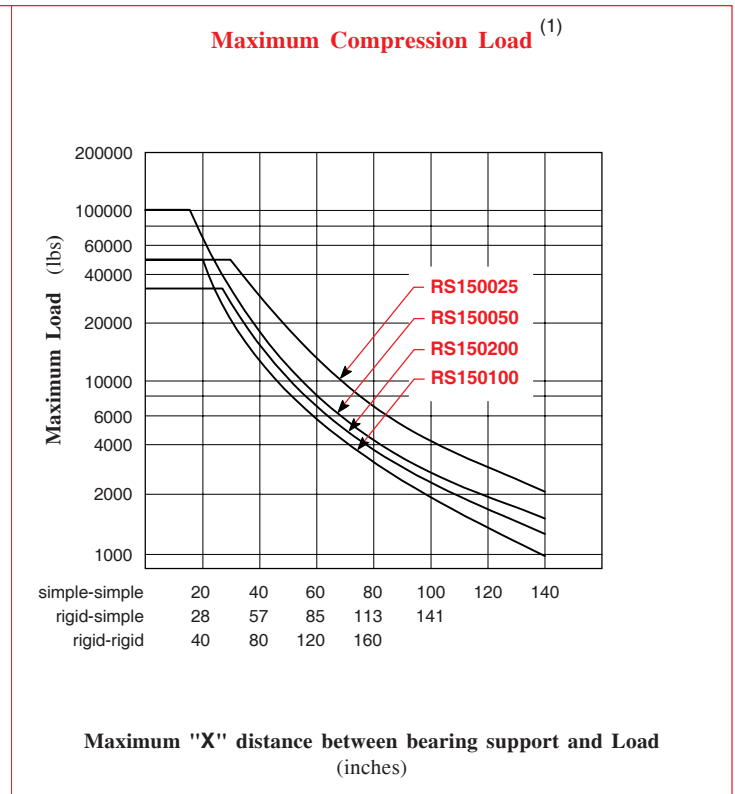
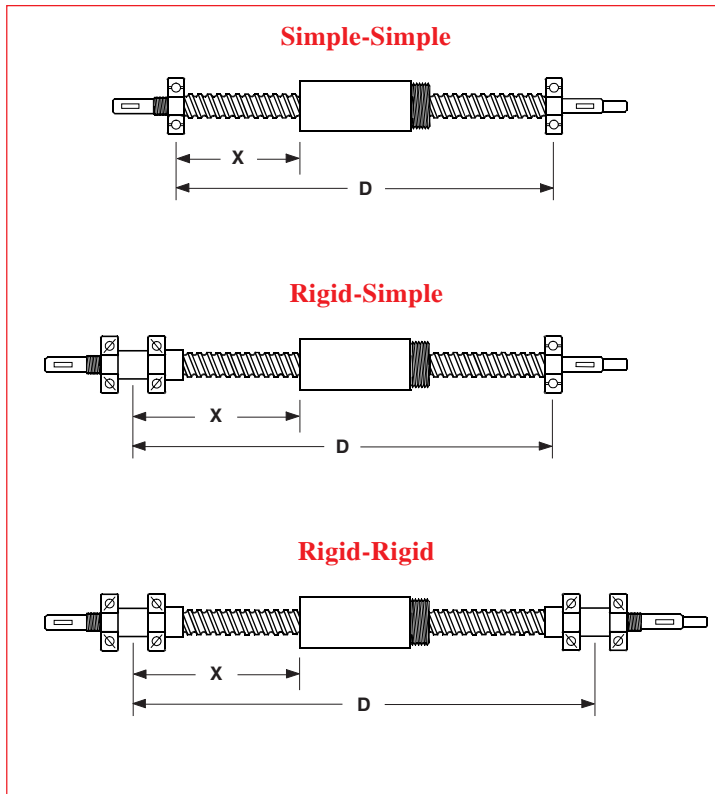

Footnotes:

- (1) Refer to the simple-simple support lengths for fixed-simple configurations. A fixed housing performs like a simple housing for critical speed and compression load specifications.
- (2) Multiply life value from chart (or graph) by 0.90 to obtain the life for a preloaded ball nut.

Specifications subject to change without notice

Nut Dimensions

Made in the U.S.A.

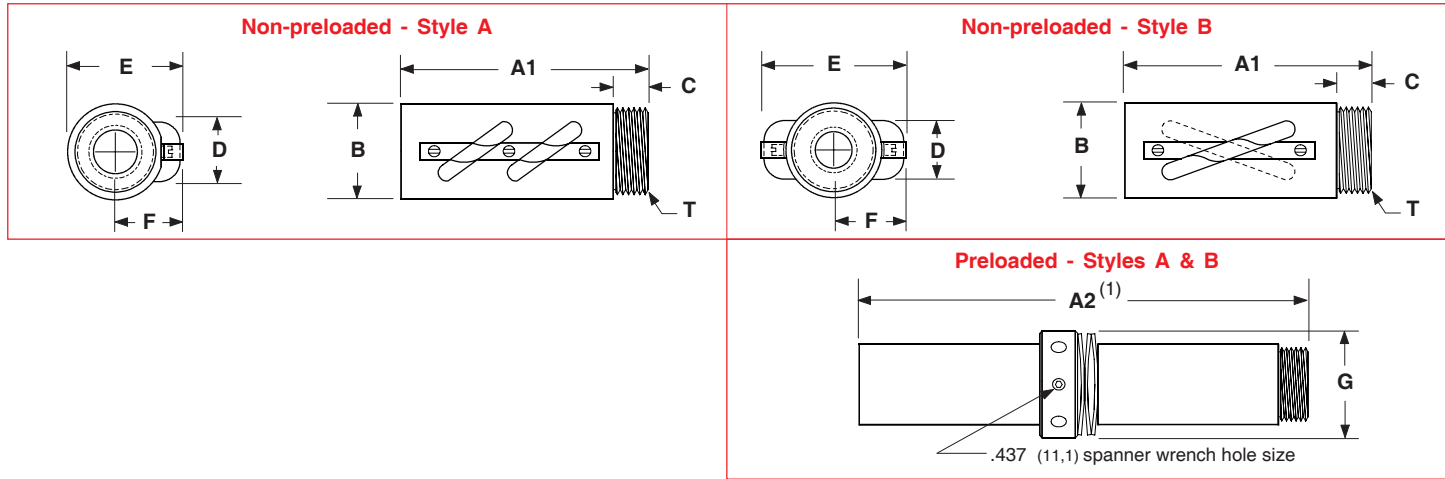

Nut Flange Dimensions

Round Flange

Weight = 3.3 lbs (1,5 kg)

(4) "L" Dia. Thru Holes on "K" Dia. BC

Nut Actual location +/- 15° from shown

	H	J	K	L
RS150025	4.410 (112,0)	.760 (19,3)	3.500 (88,9)	.397 (10,08)
RS150050	4.650 (118,1)	.750 (19,1)	3.875 (98,4)	.531 (13,49)
RS150100	4.970 (126,2)	1.000 (25,4)	4.125 (104,8)	.531 (13,49)

Vertical Bracket

Weight = 2.0 lbs (0,9 kg)

(2) .75 (19,05) Deep Holes English (F2): 1/2-20 thd. Metric (F3): M12 thd.

Nut Actual location +/- 15° from shown

	H	J	K	L
RS150025	3.875 (98,4)	2.313 (58,8)	.760 (19,3)	.380 (9,7)
RS150050	4.438 (112,7)	2.750 (69,9)	.750 (19,1)	.375 (9,5)
RS150100	4.438 (112,7)	2.750 (69,9)	1.000 (25,4)	.500 (12,7)

"L" Bracket

Weight = 4.0 lbs (1,8 kg)

(4) Holes English (F4): 1/2-20 thd. Metric (F5): M12 thd.

Nut Actual location +/- 15° from shown

	H	J	K	L	M	N
RS150025	3.875 (98,4)	2.313 (58,8)	.760 (19,3)	4.250 (107,9)	.740 (18,8)	1.510 (38,4)
RS150050	4.438 (112,7)	2.750 (69,9)	.750 (19,1)	4.250 (107,9)	.625 (15,9)	1.500 (38,1)
RS150100	4.438 (112,7)	2.750 (69,9)	1.000 (25,4)	4.500 (114,3)	.625 (15,9)	1.750 (44,5)

Model Number	Nut Style	Nut Dimensions inches (mm)									Nut (3) Weight lbs (kg)
		A1	A2 ⁽¹⁾	B	C	D	E	F	T - "V" Threads ⁽²⁾	G	
RS150025	A	3.260 (82,80)	7.000 (177,80)	2.098 (53,29)	0.760 (19,30)	1.733 (44,02)	2.427 (61,65)	1.530 (38,86)	1.967 - 18 UNS-2A (49,96 - 18 UNS-2A)	2.420 (61,47)	2.75 (1,25)
RS150050	A	5.590 (141,99)	12.100 (307,34)	2.630 (66,80)	0.755 (19,17)	1.564 (39,73)	3.177 (80,70)	1.930 (49,02)	2.360 - 18 UNS-2A (59,94 - 18 UNS-2A)	3.114 (79,09)	5.50 (2,49)
RS150100	B	3.650 (92,71)	8.160 (207,26)	2.630 (66,80)	1.010 (25,65)	1.737 (44,12)	3.696 (93,88)	1.960 (49,78)	2 1/4 - 20 UN-2A (57,15 - 20 UN-2A)	3.114 (79,09)	3.25 (1,47)
RS150200	B	5.260 (133,60)	11.250 (285,75)	2.620 (66,55)	1.005 (25,53)	1.576 (40,03)	3.400 (86,36)	1.680 (42,67)	2 1/4 - 20 UN-2A (57,15 - 20 UN-2A)	3.114 (79,09)	5.25 (2,38)

Footnotes:

- (1) This is the length for a preloaded nut. Preloaded nut consists of (2) non-preloaded nuts with a locking spanner nut, and belville springs.
- (2) All flange threads are internal (Type 2B) to match the external nut threads.
- (3) Weight of the non-preloaded nut. Multiply value by 2.1 to obtain the weight for the preloaded nut assembly.

Specifications subject to change without notice

Support Housing Dimensions

Made in the U.S.A.

Simple

Weight = 5.0 lbs (2,27 kg)

Fixed

Weight = 11.5 lbs (5,22 kg)

Rigid

Weight = 21.2 lbs (9,62 kg)

NEMA 34 Motor Mount

Weight = 4.0 lbs (1,82 kg)

NEMA 42 Motor Mount

Weight = 4.0 lbs (1,82 kg)

NEMA 42 Motor Mount

Weight = 4.0 lbs (1,82 kg)

Specifications subject to change without notice

LINTECH® Positioning Components

61

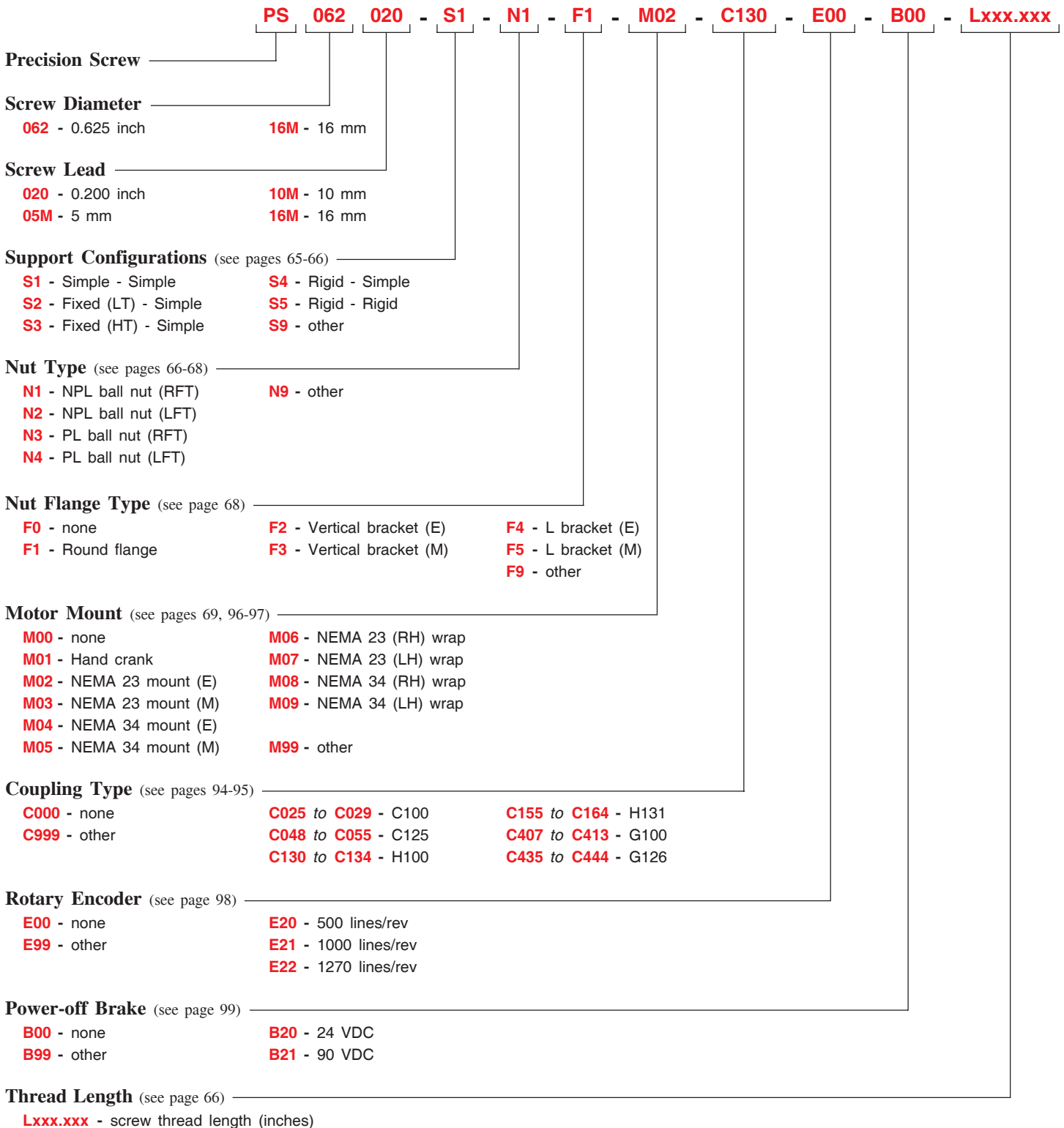

Note: See page 14 for a complete description of the above part number system.

- | | |
|----------------------------|-----------------------------|
| (E) - English Interface | (M) - Metric Interface |
| (LFT) - Left Facing Thread | (NPL) - Non Preloaded |
| (LH) - Left Hand | (PL) - Preloaded |
| (LT) - Low Thrust | (RFT) - Right Facing Thread |
| (HT) - High Thrust | (RH) - Right Hand |

Specifications subject to change without notice

Screw & Nut Specifications

Made in the U.S.A.

Model Number	Nut Type	Diameter inches (mm)	Lead inches (mm)	Root Diameter inches (mm)	Ball Diameter inches (mm)	Number of Circuits	Static Load lbs (kgf)	Dynamic Load ⁽¹⁾ lbs (kgf)
PS062020 0.625 inch dia. 0.200 inch lead	<i>Non-preloaded Ball (N1/N2)</i>	0.625 (15,87)	0.200 (5,08)	0.513 (13,03)	0.125 (3,17)	1	2,700 (1224)	876 (397)
	<i>Preloaded Ball (N3/N4)</i>						2,430 (1102)	788 (357)
PS16M05M 16 mm dia. 5 mm lead	<i>Non-preloaded Ball (N1/N2)</i>	0.629 (16,00)	0.196 (5,00)	0.513 (13,03)	0.125 (3,17)	1	2,700 (1224)	876 (397)
	<i>Preloaded Ball (N3/N4)</i>						2,430 (1102)	788 (357)
PS16M10M 16 mm dia. 10 mm lead	<i>Non-preloaded Ball (N1/N2)</i>	0.629 (16,00)	0.393 (10,00)	0.503 (12,78)	0.125 (3,17)	1	2,630 (1192)	1,080 (489)
	<i>Preloaded Ball (N3/N4)</i>						2,365 (1072)	972 (440)
PS16M16M 16 mm dia. 16 mm lead	<i>Non-preloaded Ball (N1/N2)</i>	0.629 (16,00)	0.629 (16,00)	0.529 (13,44)	0.125 (3,17)	1	1,620 (734)	819 (371)
	<i>Preloaded Ball (N3/N4)</i>						1,455 (659)	737 (334)

Other Specifications

Maximum Acceleration Rate	Ball nut: 772 inches/sec ² (19,6 m/sec ²)
Maximum Speed	Ball nut: 3000 rpm
Screw Material	Right Hand Thread, Case Hardened Rc 58 Steel Precision Rolled Ball Screw
Screw Extensions	303 Woodruff Keyways on Extensions from Support Housings
Screw Maximum Length⁽²⁾	78.74 inches (2000 mm)
Screw Weight	0.87 lbs/ft (12,0 kg/cm)
Support Housings	Steel with Black Oxide Finish, 45° Chamfer x .02 inch (0,50) all Straight Edges
Support Housing Features	Base or Face Mount with Integral Seals
Nut Flanges	Steel with Black Oxide Finish
Nut Flange Features	English or Metric Load Mounting Interface

Footnotes:

- (1) Load based upon 1 million inches (25 Km) of travel life. See page 67 for further travel life ratings.
 (2) Maximum stock length (not the maximum thread length with bearing housings). See page 66 for maximum thread lengths for each configuration.

TECHNICAL REFERENCE - 0.625 inch & 16 mm screw diameters - PS Series

Screw Specifications

Made in the U.S.A.

Model Number	Nut Type	Screw Efficiency %	Lead Error inch/ft (mm/300 mm)	Backlash inches (mm)	Unidirectional Repeatability inches (mm)	Bidirectional Repeatability inches (mm)
PS062020 0.625 inch dia. 0.200 inch lead & PS16M05M 16 mm dia. 5 mm lead & PS16M10M 16 mm dia. 10 mm lead & PS16M16M 16 mm dia. 16 mm lead	<i>Non-preloaded</i> Ball (N1/N2)	90	< 0.002 (0,050)	< 0.003 (0,076)	+/- 0.0002 (0,0050)	+ 0.0002 to - 0.0032 (0,0050) (0,0813)
	<i>Preloaded</i> Ball (N3/N4)	90	< 0.002 (0,050)	0	+/- 0.0002 (0,0050)	+ 0.0002 to - 0.0002 (0,0050) (0,0050)

Assembly Specifications

Model Number	Nut Type	Breakaway Torque oz-in (N-m)				
		Simple-Simple	Fixed(LT)-Simple	Fixed(HT)-Simple	Rigid-Simple	Rigid-Rigid
PS062020 0.625 inch dia. 0.200 inch lead	<i>Non-preloaded</i> Ball (N1/N2)	< 8 (0,06)	< 10 (0,07)	< 25 (0,18)	< 25 (0,18)	< 35 (0,24)
	<i>Preloaded</i> Ball (N3/N4)	< 15 (0,10)	< 20 (0,14)	< 35 (0,24)	< 35 (0,24)	< 45 (0,32)
PS16M05M 16 mm dia. 5 mm lead	<i>Non-preloaded</i> Ball (N1/N2)	< 8 (0,06)	< 10 (0,07)	< 25 (0,18)	< 25 (0,18)	< 35 (0,24)
	<i>Preloaded</i> Ball (N3/N4)	< 15 (0,10)	< 20 (0,14)	< 35 (0,24)	< 35 (0,24)	< 45 (0,32)
PS16M10M 16 mm dia. 10 mm lead	<i>Non-preloaded</i> Ball (N1/N2)	< 10 (0,07)	< 15 (0,11)	< 30 (0,21)	< 30 (0,21)	< 40 (0,28)
	<i>Preloaded</i> Ball (N3/N4)	< 20 (0,14)	< 25 (0,18)	< 40 (0,28)	< 40 (0,28)	< 50 (0,35)
PS16M16M 16 mm dia. 16 mm lead	<i>Non-preloaded</i> Ball (N1/N2)	< 15 (0,10)	< 20 (0,14)	< 35 (0,24)	< 35 (0,24)	< 45 (0,32)
	<i>Preloaded</i> Ball (N3/N4)	< 30 (0,21)	< 35 (0,24)	< 50 (0,35)	< 50 (0,35)	< 55 (0,39)

Specifications subject to change without notice

Support Housing Specifications

Made in the U.S.A.

Support Housing Life millions of screw revolutions	Support Housing Thrust Load Capacity - (Axial)			
	Simple	Fixed (LT)	Fixed (HT)	Rigid
Static	1,370 (621)	1,725 (782)	3,105 (1408)	3,105 (1408)
1	1,370 (621)	1,725 (782)	2,875 (1304)	2,875 (1304)
2	1,215 (551)	1,530 (694)	2,195 (996)	2,195 (996)
10	710 (322)	895 (406)	1,295 (587)	1,295 (587)
50	410 (186)	525 (238)	790 (358)	790 (358)
100	330 (150)	415 (188)	630 (286)	630 (286)
500	195 (88)	240 (109)	365 (165)	365 (165)

Thrust force applied in either direction

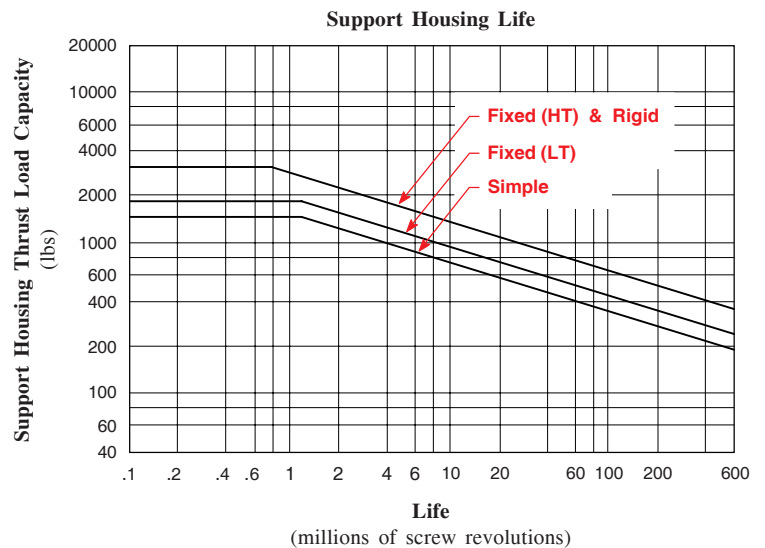
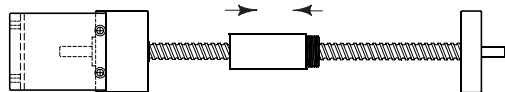

Note: Multiply screw revolutions by the screw lead in order to convert to inches (or mm) traveled by the nut.

Available Configurations

Made in the U.S.A.

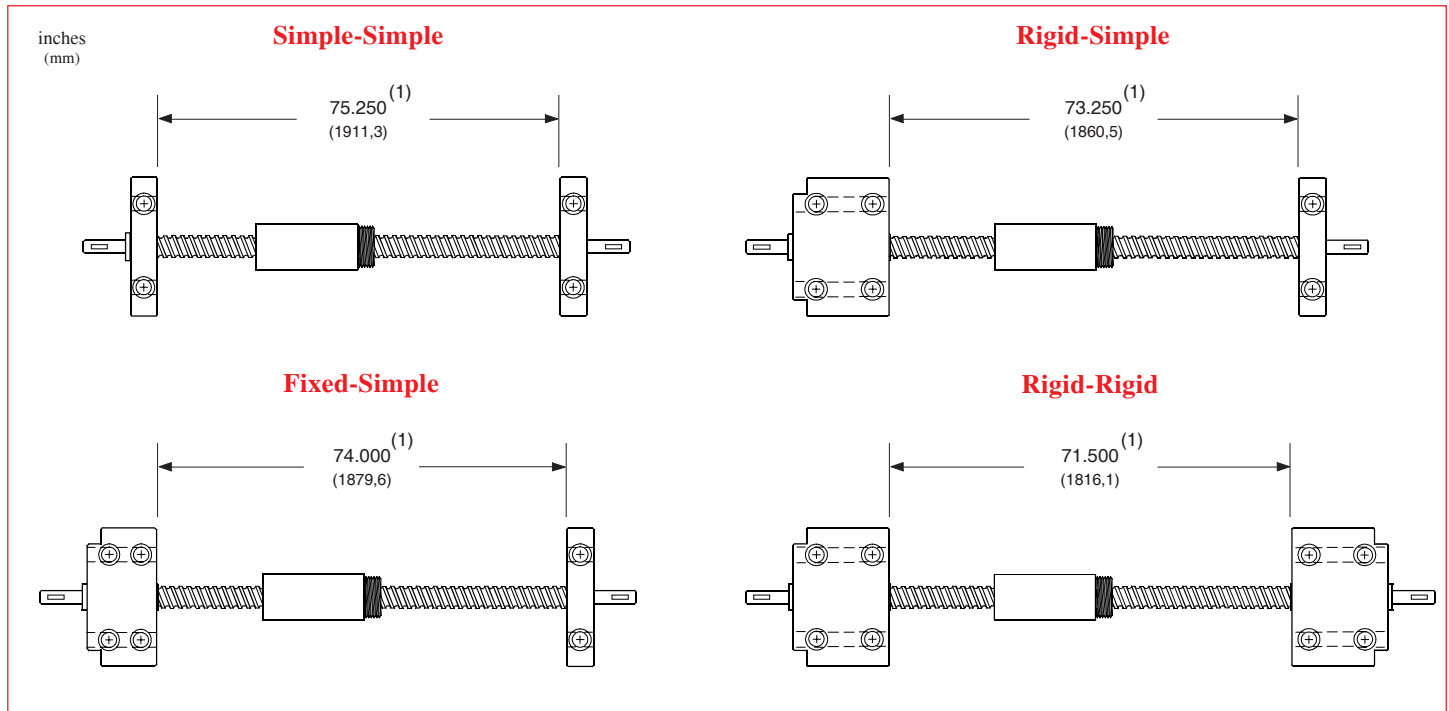

Overall Length Diagram

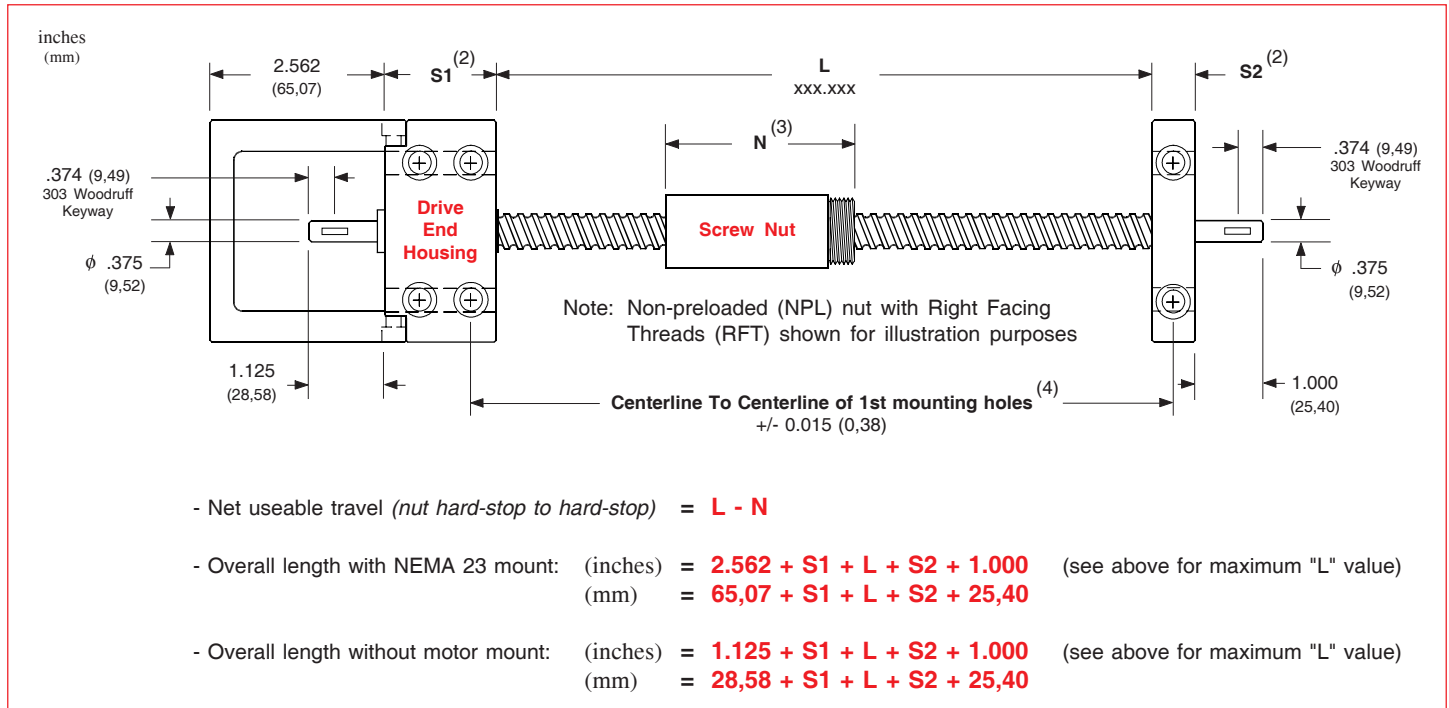

Footnotes:

- (1) Maximum available standard screw thread length for the bearing support housing configuration shown.
- (2) Fixed-simple support configuration shown for reference. See page 69 for length values for simple, fixed, and rigid housings.
- (3) See page 68 for available nut styles. Refer to A1 & A2 values for the nut length.
- (4) Tolerance shown is for base mounted support housings. Tolerance also applies to face mounted support housings.

Specifications subject to change without notice

Performance Charts

Made in the U.S.A.

Simple-Simple

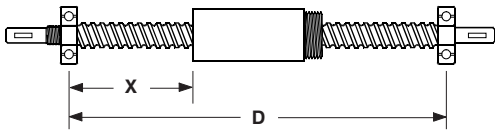

Rigid-Simple

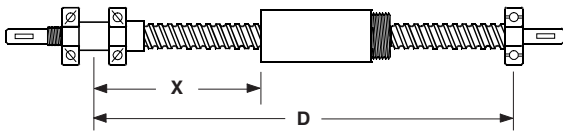

Rigid-Rigid

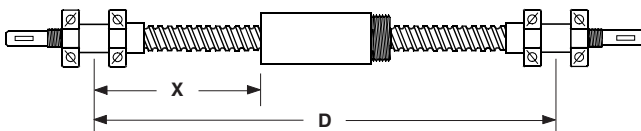

Maximum Compression Load ⁽¹⁾

X inches (mm)	simple-simple		rigid-simple		rigid-rigid	
	lbs	(kgf)	lbs	(kgf)	lbs	(kgf)
20 (508)	1620	(735)	1620	(735)	1620	(735)
40 (1016)	450	(204)	900	(408)	1620	(735)
60 (1524)	200	(91)	400	(181)	800	(363)

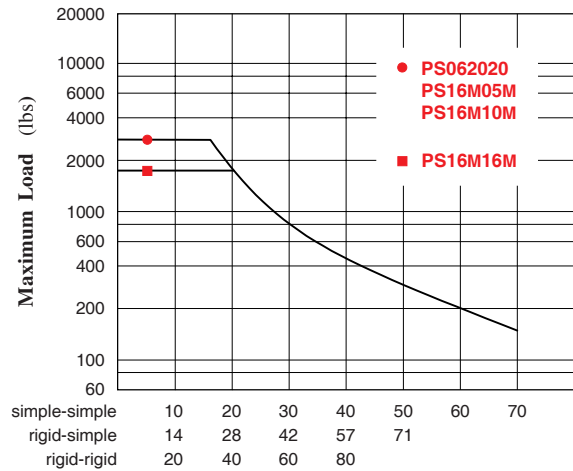

Maximum "X" distance between bearing support and Load (inches)

Maximum Speed ⁽¹⁾

D inches (mm)	simple-simple	rigid-simple	rigid-rigid
	rpm	rpm	rpm
27 (686)	3000	3000	3000
40 (1016)	1340	1970	2990
60 (1524)	595	870	1325
70 (1778)	435	640	970

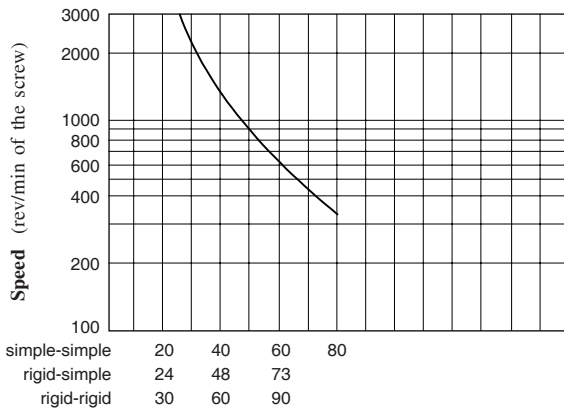

Maximum "D" distance between bearing supports (inches)

Screw Travel Life ⁽²⁾

Life millions of inches (km)	062020/16M05M		16M10M		16M16M	
	lbs	(kgf)	lbs	(kgf)	lbs	(kgf)
1 (25)	876	(397)	1,080	(489)	819	(371)
2 (50)	696	(315)	858	(389)	650	(294)
50 (1270)	240	(108)	297	(134)	225	(102)
100 (2540)	190	(86)	235	(106)	179	(81)

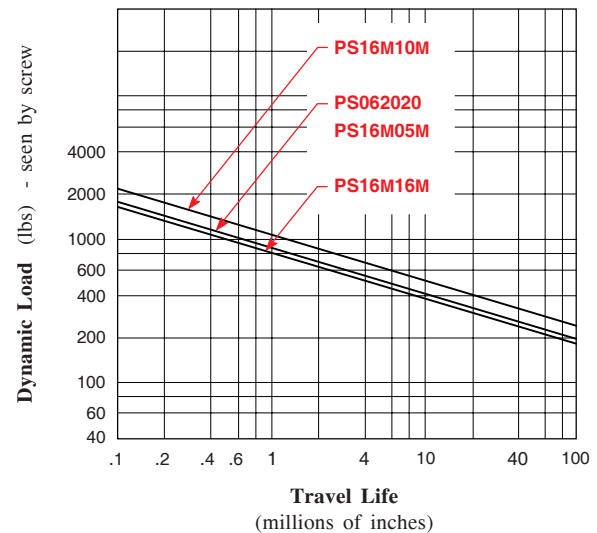

Footnotes:

- Refer to the simple-simple support lengths for fixed-simple configurations. A fixed housing performs like a simple housing for critical speed and compression load specifications.
- Multiply life value from chart (or graph) by 0.90 to obtain the life for a preloaded ball nut.

Specifications subject to change without notice

Nut Dimensions

Made in the U.S.A.

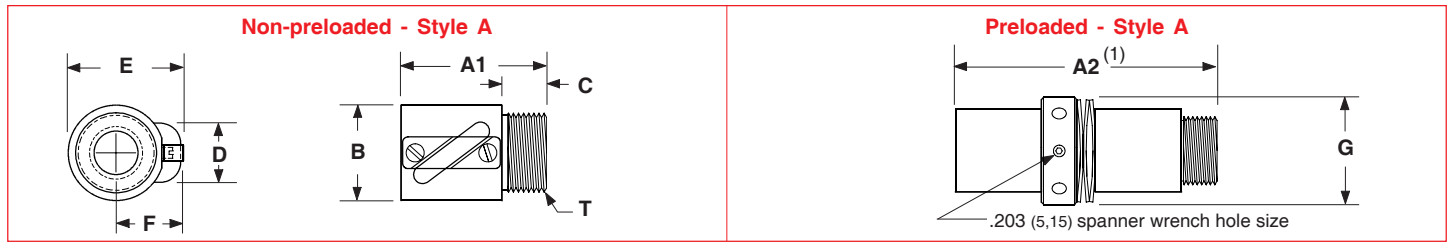

Nut Flange Dimensions

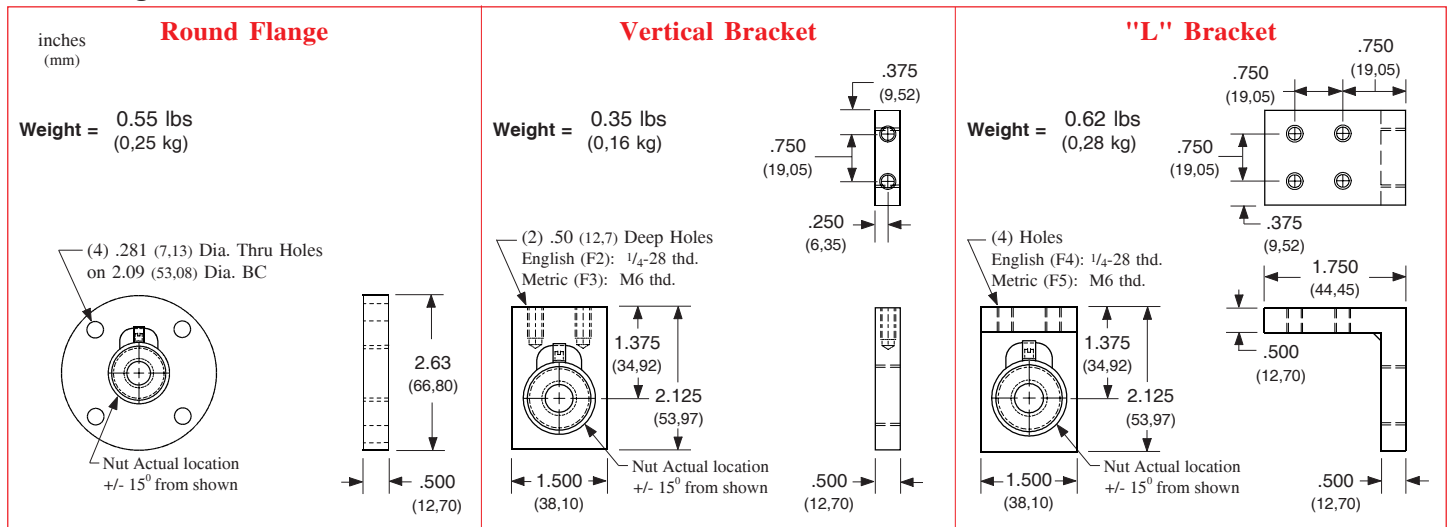

Model Number	Nut Style	Nut Dimensions inches (mm)									Nut Weight ⁽³⁾ lbs (kg)
		A1	A2 ⁽¹⁾	B	C	D	E	F	T - "V" Threads ⁽²⁾	G	
PS062020	A	1.580 (40,13)	3.410 (86,61)	1.221 (31,01)	0.500 (12,70)	0.847 (21,51)	1.398 (35,51)	0.787 (20,00)	15/16 - 16 UN-2A (23,81 - 16 UN-2A)	1.410 (35,81)	0.24 (0,11)
PS16M05M	A	1.580 (40,13)	3.410 (86,61)	1.221 (31,01)	0.500 (12,70)	0.847 (21,51)	1.398 (35,51)	0.787 (20,00)	15/16 - 16 UN-2A (23,81 - 16 UN-2A)	1.410 (35,81)	0.24 (0,11)
PS16M10M	A	2.070 (52,59)	4.370 (111,00)	1.221 (31,01)	0.500 (12,70)	0.709 (18,01)	1.398 (35,51)	0.787 (20,00)	15/16 - 16 UN-2A (23,81 - 16 UN-2A)	1.410 (35,81)	0.33 (0,15)
PS16M16M	A	2.170 (55,12)	4.630 (117,60)	1.221 (31,01)	0.500 (12,70)	0.847 (21,51)	1.398 (35,51)	0.787 (20,00)	15/16 - 16 UN-2A (23,81 - 16 UN-2A)	1.410 (35,81)	0.30 (0,14)

Footnotes:

- (1) This is the length for a preloaded nut. Preloaded nut consists of (2) non-preloaded nuts with a locking spanner nut, and belville springs.
- (2) All flange threads are internal (Type 2B) to match the external nut threads.
- (3) Weight of the non-preloaded nut. Multiply value by 2.1 to obtain the weight for the preloaded nut assembly.

Specifications subject to change without notice

Bearing Support Housing Dimensions

Made in the U.S.A.

Simple

inches (mm)

.625 (15,87)

2.000 (50,80)

(4) .343 (8,71) Dia. Thru Holes

(4) 8-32 x .37 (9,39) Deep on 1.750 (44,45) BC

2.500 (63,50)

1.750 (44,45)

1.250 (31,75)

.375 (9,52)

1.625 (41,27)

3.250 (82,55)

Weight = 1.1 lbs (0,50 kg)

.313 (7,95)

(2) .343 (8,71) Dia. Thru Holes, .504 (12,8) Dia. C'Bored x .57 (14,47) Deep

.313 (7,95)

.625 (15,87)

.625 (15,87)

Drive End

non-Drive End

Fixed

.625 (15,87)

2.000 (50,80)

(4) .343 (8,71) Dia. Thru Holes

(4) 8-32 x .37 (9,39) Deep on 1.750 (44,45) BC

2.500 (63,50)

1.750 (44,45)

1.250 (31,75)

.375 (9,52)

1.625 (41,27)

3.250 (82,55)

.250 (6,35)

Weight = 2.7 lbs (1,22 kg)

.750 (19,05)

(4) .343 (8,71) Dia. Thru Holes, .504 (12,8) Dia. C'Bored x .57 (14,47) Deep

.500 (12,70)

1.125 (28,57)

(2) 10-32 x .43 (10,92) Deep, both sides

.688 (17,47)

.125 (3,17)

1.750 (44,45)

Rigid

.625 (15,87)

2.000 (50,80)

(4) .343 (8,71) Dia. Thru Holes

(4) 8-32 x .37 (9,39) Deep on 1.750 (44,45) BC

2.500 (63,50)

1.750 (44,45)

1.250 (31,75)

.375 (9,52)

1.625 (41,27)

3.250 (82,55)

.250 (6,35)

Weight = 3.9 lbs (1,77 kg)

(4) .343 (8,71) Dia. Thru Holes, .504 (12,8) Dia. C'Bored x .57 (14,47) Deep

1.500 (38,10)

.500 (12,70)

1.125 (28,57)

(2) 10-32 x .43 (10,92) Deep, both sides

.688 (17,47)

.125 (3,17)

2.500 (63,50)

NEMA 23 Motor Mount

Weight = 0.9 lbs (0,41 kg)

(4) Holes on 2.625 (66,67) BC Dia. English (M02): #10-24 thd. Metric (M03): M5 thd.

1.502 (38,15) Pilot Dia. TYP

2.340 (59,44)

2.562 (65,07)

.313 (7,95)

1.437 (36,50)

2.250 (57,15)

1.125 (28,57)

(2) .221 (5,61) Dia. Thru Holes, .344 (8,73) Dia. C'Bored x .125 (3,17) Deep, both sides

NEMA 34 Motor Mount

Weight = 1.4 lbs (0,64 kg)

(4) Holes on 3.875 (98,42) BC Dia. English (M04): #10-24 thd. Metric (M05): M5 thd.

2.877 (73,07) Pilot Dia. TYP

.063 (1,60)

2.340 (59,44)

.500 (12,70)

2.562 (65,07)

.313 (7,95)

1.937 (49,20)

3.375 (85,72)

1.688 (42,88)

.438 (11,13)

(2) .221 (5,61) Dia. Thru Holes, .344 (8,73) Dia. C'Bored x .125 (3,17) Deep, both sides

Specifications subject to change without notice

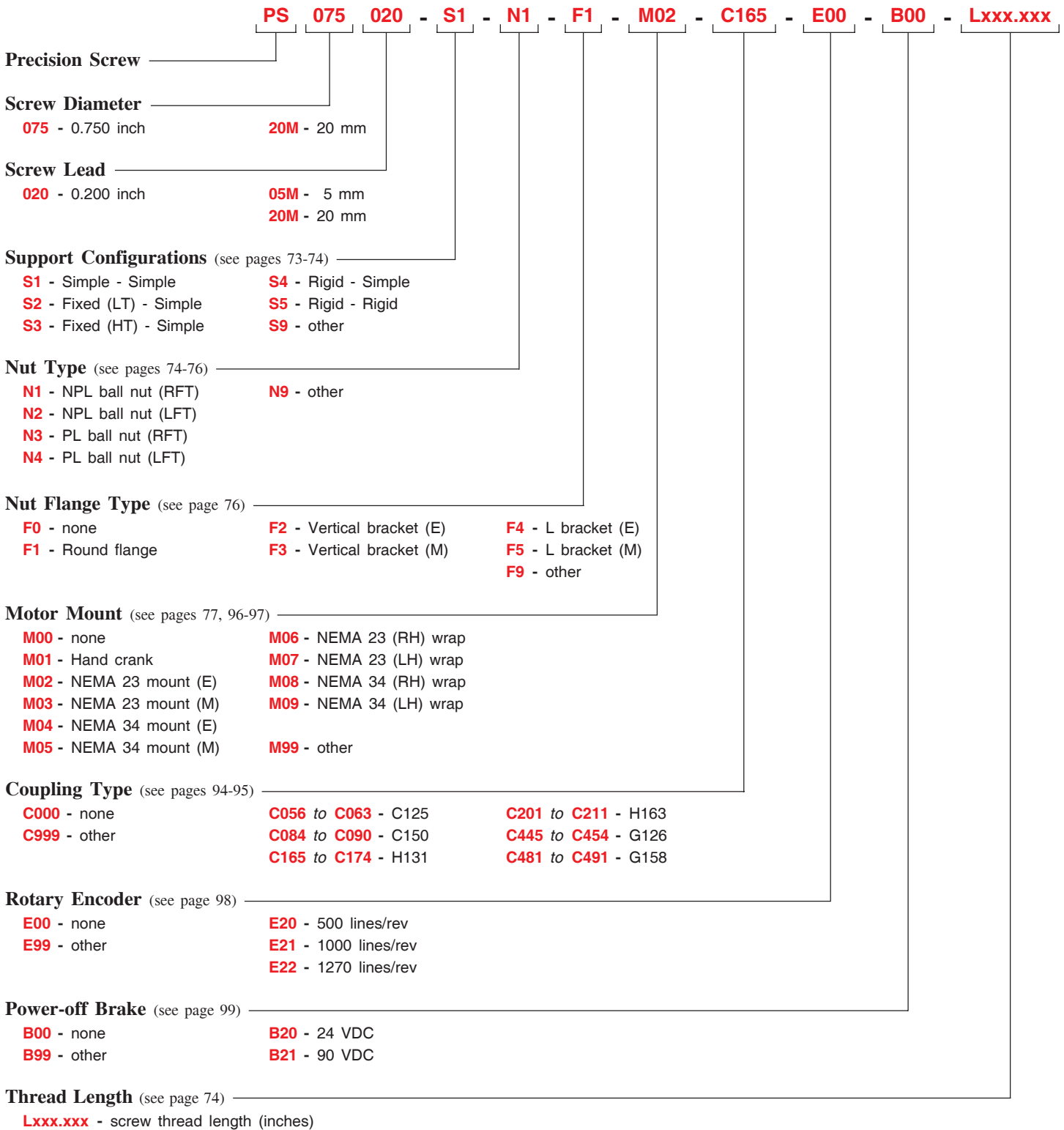

Note: See page 14 for a complete description of the above part number system.

- | | |
|----------------------------|-----------------------------|
| (E) - English Interface | (M) - Metric Interface |
| (LFT) - Left Facing Thread | (NPL) - Non Preloaded |
| (LH) - Left Hand | (PL) - Preloaded |
| (LT) - Low Thrust | (RFT) - Right Facing Thread |
| (HT) - High Thrust | (RH) - Right Hand |

Specifications subject to change without notice

Screw & Nut Specifications

Made in the U.S.A.

Model Number	Nut Type	Diameter inches (mm)	Lead inches (mm)	Root Diameter inches (mm)	Ball Diameter inches (mm)	Number of Circuits	Static Load lbs (kgf)	Dynamic Load ⁽¹⁾ lbs (kgf)
PS075020 0.750 inch dia. 0.200 inch lead	<i>Non-preloaded</i> Ball (N1/N2)	0.750 (19,05)	0.200 (5,08)	0.635 (16,13)	0.125 (3,17)	1	3,360 (1524)	964 (437)
	<i>Preloaded</i> Ball (N3/N4)						3,025 (1372)	867 (393)
PS20M05M 20 mm dia. 5 mm lead	<i>Non-preloaded</i> Ball (N1/N2)	0.787 (20,00)	0.196 (5,00)	0.665 (16,89)	0.125 (3,17)	1	3,990 (1809)	1,070 (485)
	<i>Preloaded</i> Ball (N3/N4)						3,590 (1628)	960 (435)
PS20M20M 20 mm dia. 20 mm lead	<i>Non-preloaded</i> Ball (N1/N2)	0.787 (20,00)	0.787 (20,00)	0.672 (17,07)	0.125 (3,17)	2	3,505 (1589)	1,293 (586)
	<i>Preloaded</i> Ball (N3/N4)						3,150 (1428)	1,160 (526)

Other Specifications

Maximum Acceleration Rate	Ball nut: 772 inches/sec ² (19,6 m/sec ²)
Maximum Speed	Ball nut: 3000 rpm
Screw Material	Right Hand Thread, Case Hardened Rc 58 Steel Precision Rolled Ball Screw
Screw Extensions	Woodruff Keyways on Support Housings - 304 Drive End; 303 Opposite End
Screw Maximum Length ⁽²⁾	118.11 inches (3000 mm)
Screw Weight	1.35 lbs/ft (18,7 kg/cm)
Support Housings	Steel with Black Oxide Finish, 45° Chamfer x .02 inch (0,50) all Straight Edges
Support Housing Features	Base or Face Mount with Integral Seals
Nut Flanges	Steel with Black Oxide Finish
Nut Flange Features	English or Metric Load Mounting Interface

Footnotes:

(1) Load based upon 1 million inches (25 Km) of travel life. See page 75 for further travel life ratings.

(2) Maximum stock length (not the maximum thread length with bearing housings). See page 74 for maximum thread lengths for each configuration.

TECHNICAL REFERENCE - 0.750 inch & 20 mm screw diameters - PS Series

Screw Specifications

Made in the U.S.A.

Model Number	Nut Type	Screw Efficiency %	Lead Error inch/ft (mm/300 mm)	Backlash inches (mm)	Unidirectional Repeatability inches (mm)	Bidirectional Repeatability inches (mm)
PS075020 0.750 inch dia. 0.200 inch lead & PS20M05M 20 mm dia. 5 mm lead & PS20M20M 20 mm dia. 20 mm lead	<i>Non-preloaded</i> Ball (N1/N2)	90	< 0.002 (0,050)	< 0.003 (0,076)	+/- 0.0002 (0,0050)	+ 0.0002 to - 0.0032 (0,0050) (0,0813)
	<i>Preloaded</i> Ball (N3/N4)	90	< 0.002 (0,050)	0	+/- 0.0002 (0,0050)	+ 0.0002 to - 0.0002 (0,0050) (0,0050)

Assembly Specifications

Model Number	Nut Type	Breakaway Torque oz-in (N-m)				
		Simple-Simple	Fixed(LT)-Simple	Fixed(HT)-Simple	Rigid-Simple	Rigid-Rigid
PS075020 0.750 inch dia. 0.200 inch lead	<i>Non-preloaded</i> Ball (N1/N2)	< 10 (0,07)	< 15 (0,11)	< 25 (0,18)	< 25 (0,18)	< 45 (0,32)
	<i>Preloaded</i> Ball (N3/N4)	< 20 (0,14)	< 25 (0,18)	< 35 (0,25)	< 35 (0,25)	< 55 (0,39)
PS20M05M 20 mm dia. 5 mm lead	<i>Non-preloaded</i> Ball (N1/N2)	< 10 (0,07)	< 15 (0,11)	< 25 (0,18)	< 25 (0,18)	< 45 (0,32)
	<i>Preloaded</i> Ball (N3/N4)	< 20 (0,14)	< 25 (0,18)	< 35 (0,25)	< 35 (0,25)	< 55 (0,39)
PS20M20M 20 mm dia. 20 mm lead	<i>Non-preloaded</i> Ball (N1/N2)	< 20 (0,14)	< 25 (0,18)	< 40 (0,28)	< 40 (0,28)	< 55 (0,39)
	<i>Preloaded</i> Ball (N3/N4)	< 35 (0,25)	< 40 (0,28)	< 55 (0,39)	< 55 (0,39)	< 70 (0,49)

Specifications subject to change without notice

Support Housing Specifications

Made in the U.S.A.

Support Housing Life millions of screw revolutions	Support Housing Thrust Load Capacity - (Axial)			
	Simple	Fixed (LT)	Fixed (HT)	Rigid
Static	1,675 (760)	2,110 (957)	3,350 (1520)	3,350 (1520)
1	1,675 (760)	2,110 (957)	3,035 (1377)	3,035 (1377)
2	1,365 (619)	1,720 (780)	2,275 (1032)	2,275 (1032)
10	795 (361)	1,050 (476)	1,375 (624)	1,375 (624)
50	465 (211)	585 (265)	820 (372)	820 (372)
100	370 (168)	465 (211)	650 (295)	650 (295)
500	215 (98)	270 (122)	390 (177)	390 (177)

Thrust force applied in either direction

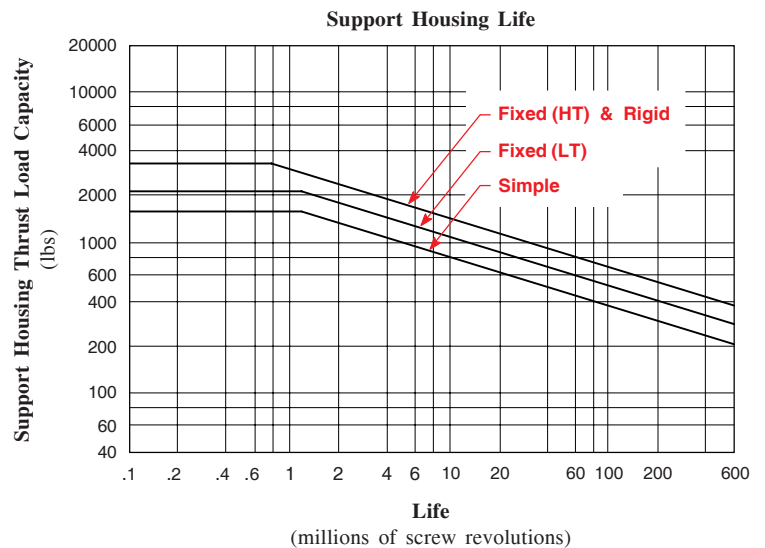
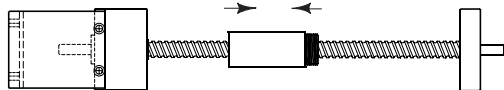

Note: Multiply screw revolutions by the screw lead in order to convert to inches (or mm) traveled by the nut.

Available Configurations

Made in the U.S.A.

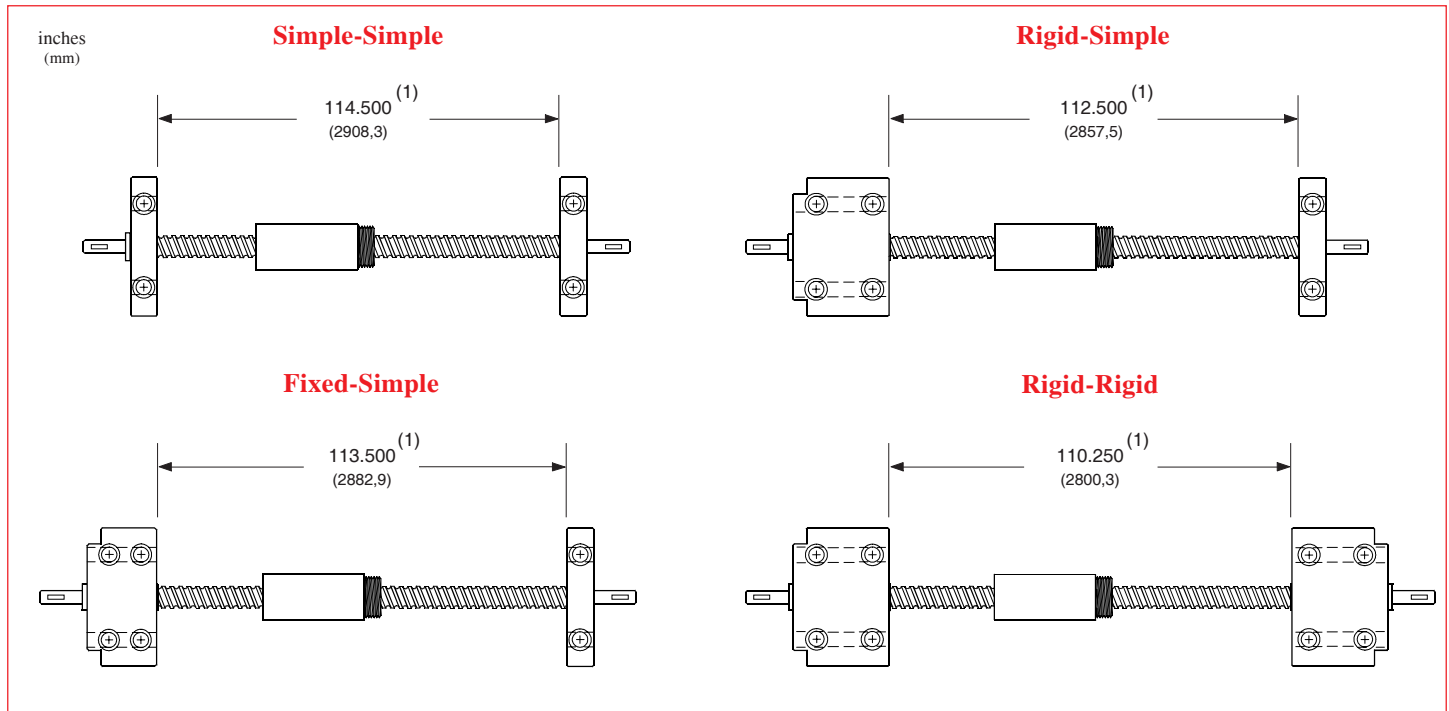

Overall Length Diagram

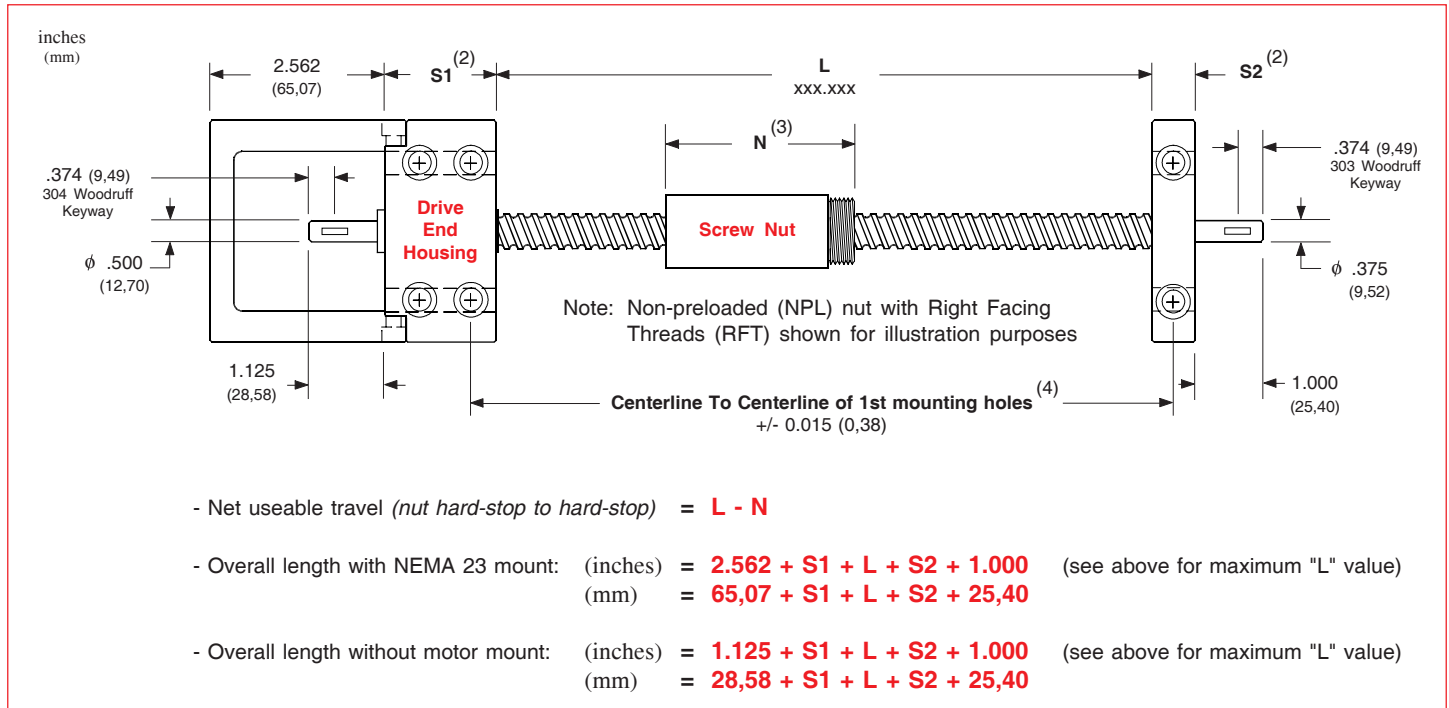

Footnotes:

- (1) Maximum available standard screw thread length for the bearing support housing configuration shown.
- (2) Fixed-simple support configuration shown for reference. See page 77 for length values for simple, fixed, and rigid housings.
- (3) See page 76 for available nut styles. Refer to A1 & A2 values for the nut length.
- (4) Tolerance shown is for base mounted support housings. Tolerance also applies to face mounted support housings.

Performance Charts

Made in the U.S.A.

Simple-Simple

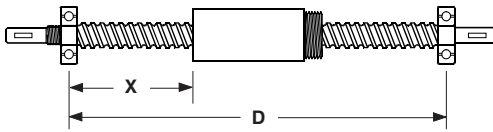

Rigid-Simple

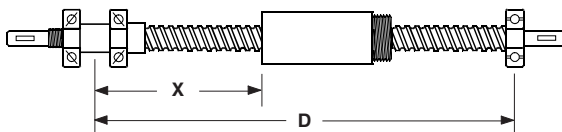

Rigid-Rigid

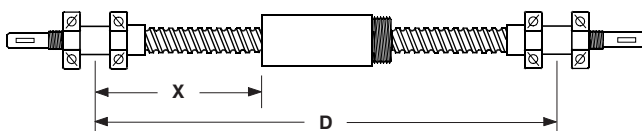

Maximum Compression Load ⁽¹⁾

X inches (mm)	simple-simple		rigid-simple		rigid-rigid	
	lbs	(kgf)	lbs	(kgf)	lbs	(kgf)
20 (508)	3360	(1524)	3360	(1524)	3360	(1524)
60 (1524)	505	(229)	1010	(458)	2020	(916)
90 (2286)	225	(102)	450	(204)	900	(408)

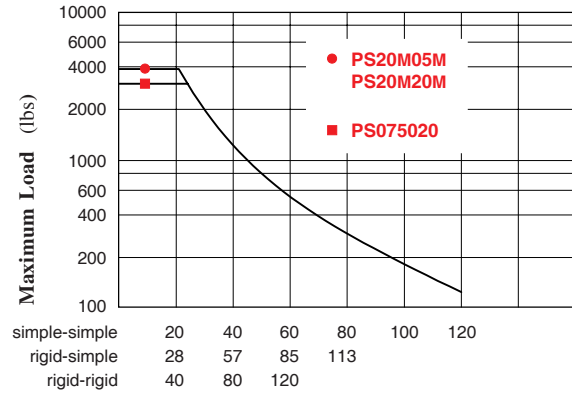

Maximum "X" distance between bearing support and Load (inches)

Maximum Speed ⁽¹⁾

D inches (mm)	simple-simple		rigid-simple		rigid-rigid	
	rpm	rpm	rpm	rpm	rpm	rpm
29 (737)	3000	3000	3000	3000	3000	3000
60 (1524)	730	730	1070	1070	1625	1625
90 (2286)	325	325	475	475	720	720
120 (3048)	180	180	260	260	400	400

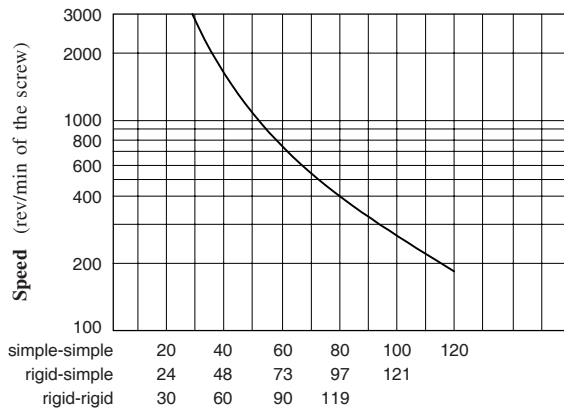

Maximum "D" distance between bearing supports (inches)

Screw Travel Life ⁽²⁾

Life millions of inches (km)	075020		20M05M		20M20M	
	lbs	(kgf)	lbs	(kgf)	lbs	(kgf)
1 (25)	964	(437)	1070	(485)	1293	(386)
2 (50)	767	(347)	850	(385)	1029	(466)
50 (1270)	265	(120)	294	(133)	355	(161)
100 (2540)	210	(95)	234	(106)	283	(128)

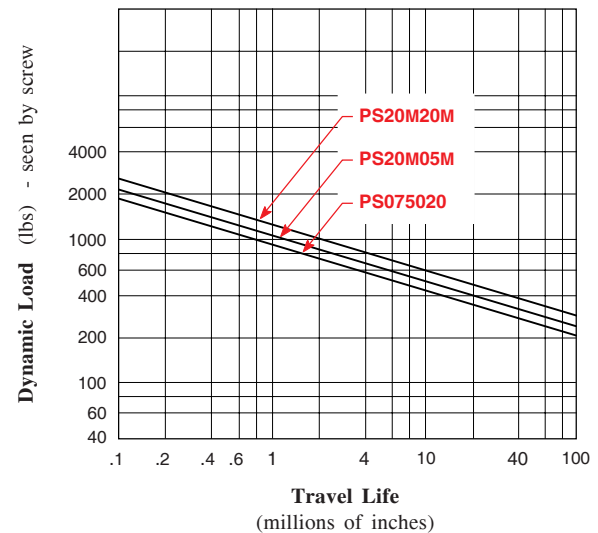

Footnotes:

- Refer to the simple-simple support lengths for fixed-simple configurations. A fixed housing performs like a simple housing for critical speed and compression load specifications.
- Multiply life value from chart (or graph) by 0.90 to obtain the life for a preloaded ball nut.

Specifications subject to change without notice

Nut Dimensions

Made in the U.S.A.

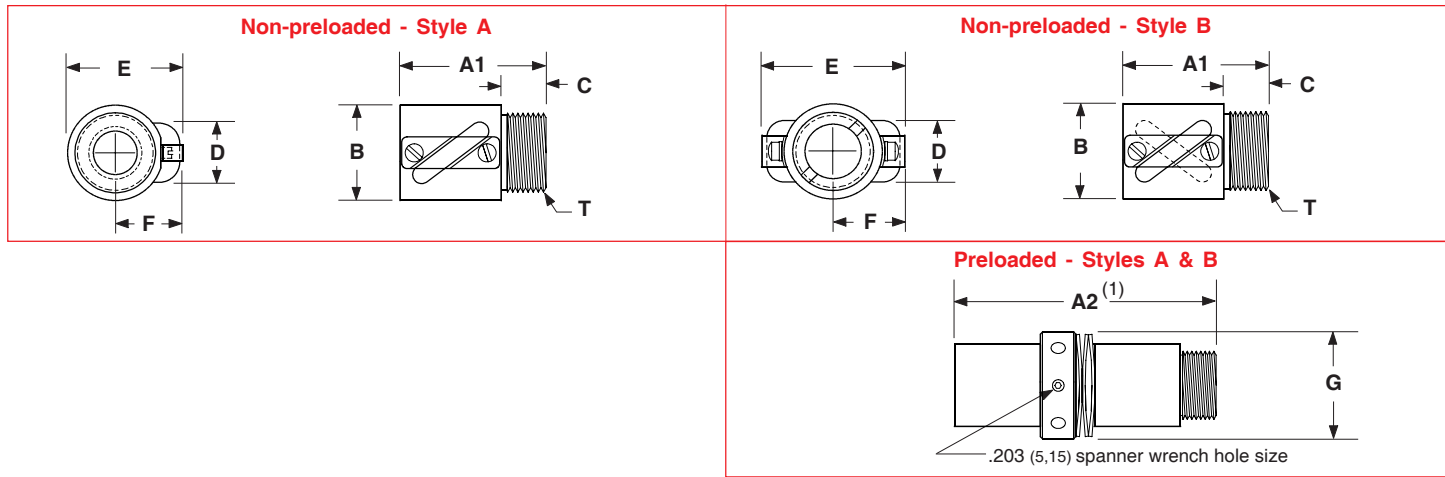

Nut Flange Dimensions

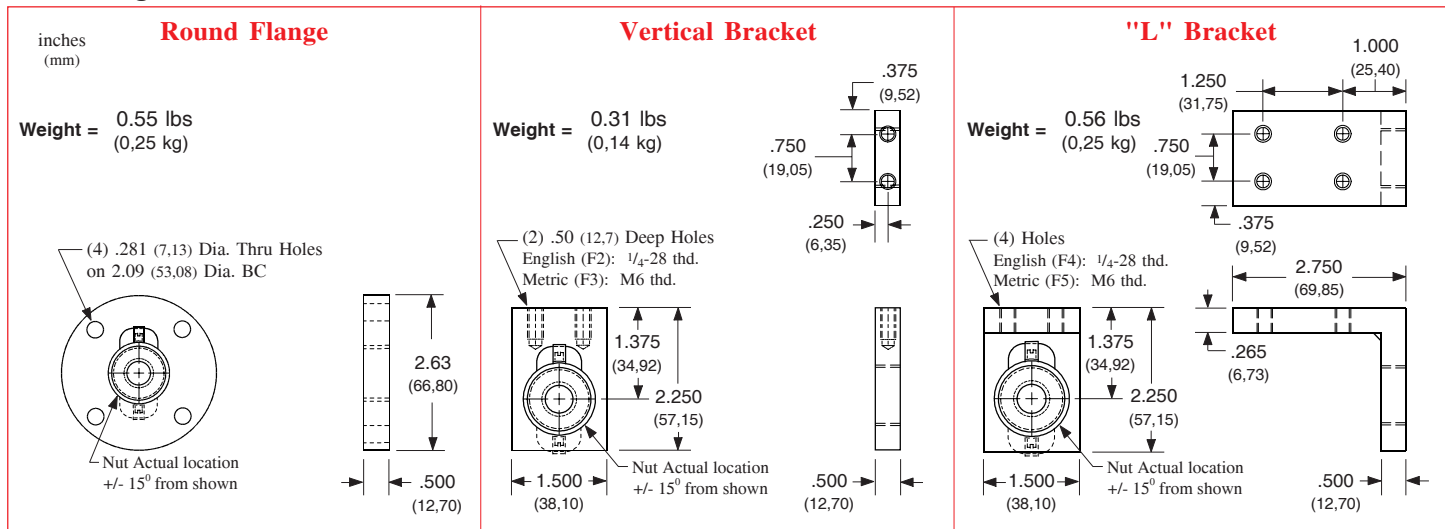

Model Number	Nut Style	Nut Dimensions inches (mm)									Nut Weight lbs (kg)
		A1	A2 ⁽¹⁾	B	C	D	E	F	T - "V" Threads ⁽²⁾	G	
PS075020	A	1.780 (45,21)	3.850 (97,79)	1.378 (35,00)	0.500 (12,70)	1.063 (27,00)	1.674 (42,52)	0.985 (25,02)	1.173 - 18 UNS-2A (29,79 - 18 UNS-2A)	1.670 (42,42)	0.68 (0,31)
PS20M05M	A	1.780 (45,21)	3.850 (97,79)	1.378 (35,00)	0.500 (12,70)	1.063 (27,00)	1.674 (42,52)	0.985 (25,02)	1.173 - 18 UNS-2A (29,79 - 18 UNS-2A)	1.670 (42,42)	0.68 (0,31)
PS20M20M	B	2.370 (60,20)	5.050 (128,27)	1.418 (36,02)	0.500 (12,70)	1.103 (28,02)	2.126 (54,00)	1.063 (27,00)	1 1/4 - 16 UN-2A (31,75 - 16 UN-2A)	1.670 (42,42)	0.90 (0,41)

Footnotes:

- (1) This is the length for a preloaded nut. Preloaded nut consists of (2) non-preloaded nuts with a locking spanner nut, and belville springs.
- (2) All flange threads are internal (Type 2B) to match the external nut threads.
- (3) Weight of the non-preloaded nut. Multiply value by 2.1 to obtain the weight for the preloaded nut assembly.

Specifications subject to change without notice

Support Housing Dimensions

Made in the U.S.A.

<p>inches (mm)</p> <p>.625 (15,87)</p> <p>2.000 (50,80)</p> <p>(4) .343 (8,71) Dia.Thru Holes</p> <p>(4) 8-32 x .37 (9,39) Deep on 1.750 (44,45) BC</p> <p>2.500 (63,50)</p> <p>1.750 (44,45)</p> <p>1.250 (31,75)</p> <p>.375 (9,52)</p> <p>1.625 (41,27)</p> <p>3.250 (82,55)</p>	<p>Simple</p> <p>Weight = 1.1 lbs (0,50 kg)</p>	<p>.313 (7,95)</p> <p>(2) .343 (8,71) Dia. Thru Holes, .504 (12,8) Dia. C'Bored x .57 (14,47) Deep</p> <p>.313 (7,95)</p> <p>.625 (15,87)</p> <p>Drive End</p> <p>non-Drive End</p>
<p>.625 (15,87)</p> <p>2.000 (50,80)</p> <p>(4) .343 (8,71) Dia.Thru Holes</p> <p>(4) 8-32 x .37 (9,39) Deep on 1.750 (44,45) BC</p> <p>2.500 (63,50)</p> <p>1.750 (44,45)</p> <p>1.250 (31,75)</p> <p>.375 (9,52)</p> <p>1.625 (41,27)</p> <p>3.250 (82,55)</p> <p>.250 (6,35)</p>	<p>Fixed</p> <p>Weight = 2.7 lbs (1,22 kg)</p>	<p>.750 (19,05)</p> <p>(4) .343 (8,71) Dia. Thru Holes, .504 (12,8) Dia. C'Bored x .57 (14,47) Deep</p> <p>1.125 (28,57)</p> <p>(2) 10-32 x .43 (10,92) Deep, both sides</p> <p>.688 (17,47)</p> <p>.125 (3,17)</p> <p>1.750 (44,45)</p>
<p>.625 (15,87)</p> <p>2.000 (50,80)</p> <p>(4) .343 (8,71) Dia.Thru Holes</p> <p>(4) 8-32 x .37 (9,39) Deep on 1.750 (44,45) BC</p> <p>2.500 (63,50)</p> <p>1.750 (44,45)</p> <p>1.250 (31,75)</p> <p>.375 (9,52)</p> <p>1.625 (41,27)</p> <p>3.250 (82,55)</p> <p>.250 (6,35)</p>	<p>Rigid</p> <p>Weight = 4.0 lbs (1,81 kg)</p>	<p>.750 (19,05)</p> <p>(4) .343 (8,71) Dia. Thru Holes, .504 (12,8) Dia. C'Bored x .57 (14,47) Deep</p> <p>1.125 (28,57)</p> <p>(2) 10-32 x .43 (10,92) Deep, both sides</p> <p>.688 (17,47)</p> <p>.125 (3,17)</p> <p>1.750 (44,45)</p> <p>.500 (12,70)</p> <p>2.750 (69,85)</p>
<p>NEMA 23 Motor Mount</p> <p>Weight = 0.9 lbs (0,41 kg)</p> <p>(4) Holes on 2.625 (66,67) BC Dia. English (M02): #10-24 thd. Metric (M03): M5 thd.</p> <p>1.502 (38,15) Pilot Dia. TYP</p> <p>2.340 (59,44)</p> <p>2.562 (65,07)</p> <p>.313 (7,95)</p> <p>1.437 (36,50)</p> <p>2.250 (57,15)</p> <p>1.125 (28,57)</p> <p>(2) .221 (5,61) Dia.Thru Holes, .344 (8,73) Dia. C'Bored x .125 (3,17) Deep, both sides</p>	<p>NEMA 34 Motor Mount</p> <p>Weight = 1.4 lbs (0,64 kg)</p> <p>(4) Holes on 3.875 (98,42) BC Dia. English (M04): #10-24 thd. Metric (M05): M5 thd.</p> <p>2.877 (73,07) Pilot Dia. TYP</p> <p>.063 (1,60)</p> <p>2.340 (59,44)</p> <p>.500 (12,70)</p> <p>2.562 (65,07)</p> <p>.313 (7,95)</p> <p>1.937 (49,20)</p> <p>3.375 (85,72)</p> <p>1.688 (42,88)</p> <p>.438 (11,13)</p> <p>(2) .221 (5,61) Dia.Thru Holes, .344 (8,73) Dia. C'Bored x .125 (3,17) Deep, both sides</p>	

Specifications subject to change without notice

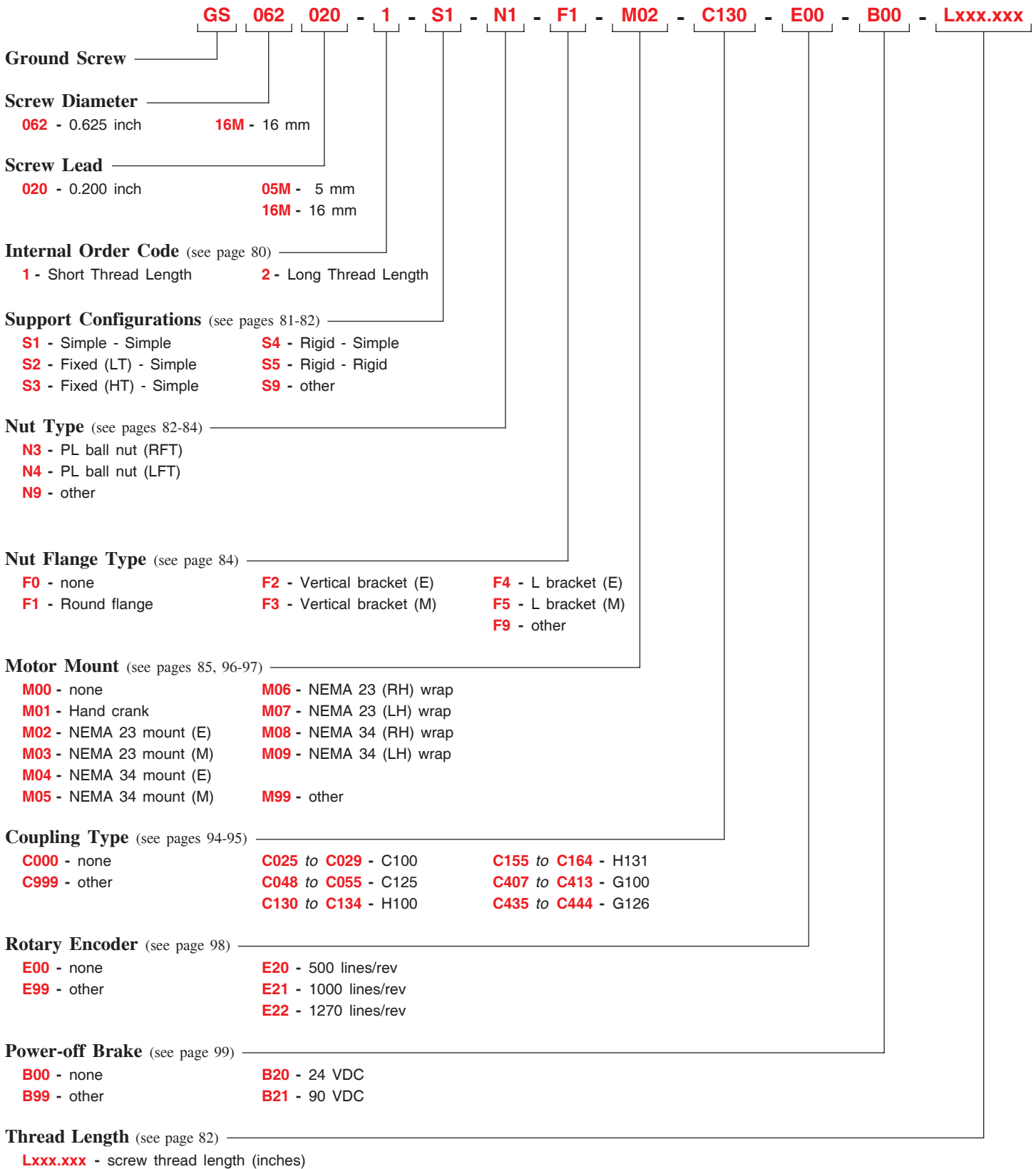

Note: See page 14 for a complete description of the above part number system.

- | | |
|----------------------------|-----------------------------|
| (E) - English Interface | (M) - Metric Interface |
| (LFT) - Left Facing Thread | (NPL) - Non Preloaded |
| (LH) - Left Hand | (PL) - Preloaded |
| (LT) - Low Thrust | (RFT) - Right Facing Thread |
| (HT) - High Thrust | (RH) - Right Hand |

Specifications subject to change without notice

Screw & Nut Specifications

Made in the U.S.A.

Model Number	Nut Type	Diameter inches (mm)	Lead inches (mm)	Root Diameter inches (mm)	Ball Diameter inches (mm)	Number of Circuits	Static Load lbs (kgf)	Dynamic Load ⁽¹⁾ lbs (kgf)
GS062020 0.625 inch dia. 0.200 inch lead	<i>Preloaded</i> Ball (N3/N4)	0.625 (15,87)	0.200 (5,08)	0.513 (13,03)	0.125 (3,17)	1	3,080 (1397)	987 (447)
GS16M05M 16 mm dia. 5 mm lead	<i>Preloaded</i> Ball (N3/N4)	0.629 (16,00)	0.196 (5,00)	0.513 (13,03)	0.125 (3,17)	1	3,080 (1397)	987 (447)
GS16M16M 16 mm dia. 16 mm lead	<i>Preloaded</i> Ball (N3/N4)	0.629 (16,00)	0.629 (16,00)	0.529 (13,44)	0.125 (3,17)	1	1,800 (816)	910 (412)

Other Specifications

Maximum Acceleration Rate	Ball nut: 772 inches/sec ² (19,6 m/sec ²)
Maximum Speed	Ball nut: 3000 rpm
Screw Material	Right Hand Thread, Case Hardened Rc 58 Steel Ground Ball Screw
Screw Extensions	303 Woodruff Keyways on Extensions from Support Housings
Screw Maximum Length ⁽²⁾	45.27 inches (1150 mm)
Screw Weight	0.87 lbs/ft (12,0 kg/cm)
Support Housings	Steel with Black Oxide Finish, 45° Chamfer x .02 inch (0,50) all Straight Edges
Support Housing Features	Base or Face Mount with Integral Seals
Nut Flanges	Steel with Black Oxide Finish
Nut Flange Features	English or Metric Load Mounting Interface

Footnotes:

- (1) Load based upon 1 million inches (25 Km) of travel life. See page 83 for further travel life ratings.
 (2) Maximum stock length (not the maximum thread length with bearing housings). See page 82 for maximum thread lengths for each configuration.

TECHNICAL REFERENCE - 0.625 inch & 16 mm screw diameters - GS Series

Screw Specifications

Made in the U.S.A.

Model Number	Nut Type	Screw Efficiency %	Lead Error inch/ft (mm/300 mm)	Backlash inches (mm)	Unidirectional Repeatability inches (mm)	Bidirectional Repeatability inches (mm)
GS062020 0.625 inch dia. 0.200 inch lead & GS16M05M 16 mm dia. 5 mm lead & GS16M16M 16 mm dia. 16 mm lead	<i>Preloaded Ball (N3/N4)</i>	90	< 0.0005 (0,012)	0	+/- 0.0001 (0,0025)	+ 0.0001 to - 0.0001 (0,0025) (0,0025)

Assembly Specifications

Model Number	Nut Type	Breakaway Torque oz-in (N-m)				
		Simple-Simple	Fixed(LT)-Simple	Fixed(HT)-Simple	Rigid-Simple	Rigid-Rigid
GS062020 0.625 inch dia. 0.200 inch lead	<i>Preloaded Ball (N3/N4)</i>	< 15 (0,11)	< 20 (0,14)	< 30 (0,21)	< 30 (0,21)	< 40 (0,28)
GS16M05M 16 mm dia. 5 mm lead	<i>Preloaded Ball (N3/N4)</i>	< 15 (0,11)	< 20 (0,14)	< 30 (0,21)	< 30 (0,21)	< 40 (0,28)
GS16M16M 16 mm dia. 16 mm lead	<i>Preloaded Ball (N3/N4)</i>	< 25 (0,18)	< 35 (0,24)	< 45 (0,32)	< 45 (0,32)	< 55 (0,39)

Internal Order Code

Model Number	Internal Order Code & Support Configuration	Maximum Thread Length "L" inches (mm)	Model Number	Internal Order Code & Support Configuration	Maximum Thread Length "L" inches (mm)	Model Number	Internal Order Code & Support Configuration	Maximum Thread Length "L" inches (mm)
GS062020 0.625 inch dia. 0.200 inch lead & GS16M05M 16 mm dia. 5 mm lead & GS16M16M 16 mm dia. 16 mm lead	-1-S1	18.250 (463,6)	GS062020 0.625 inch dia. 0.200 inch lead	-2-S1	41.500 (1054,1)	GS16M05M 16 mm dia. 5 mm lead & GS16M16M 16 mm dia. 16 mm lead	-2-S1	37.500 (952,5)
	-1-S2	18.250 (463,6)		-2-S2	41.500 (1054,1)		-2-S2	37.500 (952,5)
	-1-S3	18.250 (463,6)		-2-S3	41.500 (1054,1)		-2-S3	37.500 (952,5)
	-1-S4	18.250 (463,6)		-2-S4	41.500 (1054,1)		-2-S4	37.500 (952,5)
	-1-S5	16.500 (419,1)		-2-S5	39.750 (1009,6)		-2-S5	35.800 (909,3)

Specifications subject to change without notice

Support Housing Specifications

Made in the U.S.A.

Support Housing Life millions of screw revolutions	Support Housing Thrust Load Capacity - (Axial)			
	Simple	Fixed (LT)	Fixed (HT)	Rigid
Static	1,370 (621)	1,725 (782)	3,105 (1408)	3,105 (1408)
1	1,370 (621)	1,725 (782)	2,875 (1304)	2,875 (1304)
2	1,215 (551)	1,530 (694)	2,195 (996)	2,195 (996)
10	710 (322)	895 (406)	1,295 (587)	1,295 (587)
50	410 (186)	525 (238)	790 (358)	790 (358)
100	330 (150)	415 (188)	630 (286)	630 (286)
500	195 (88)	240 (109)	365 (166)	365 (166)

Thrust force applied in either direction

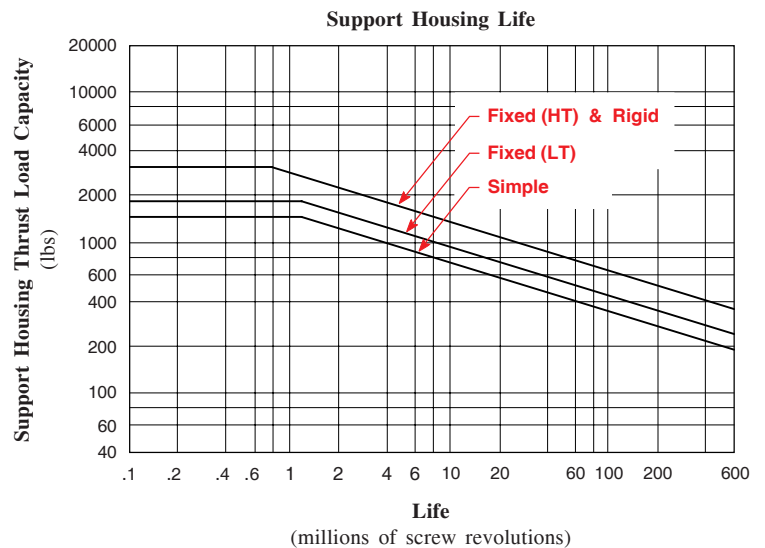
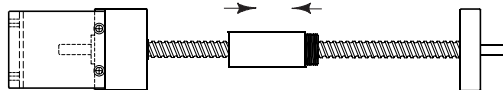

Note: Multiply screw revolutions by the screw lead in order to convert to inches (or mm) traveled by the nut.

Available Configurations

Made in the U.S.A.

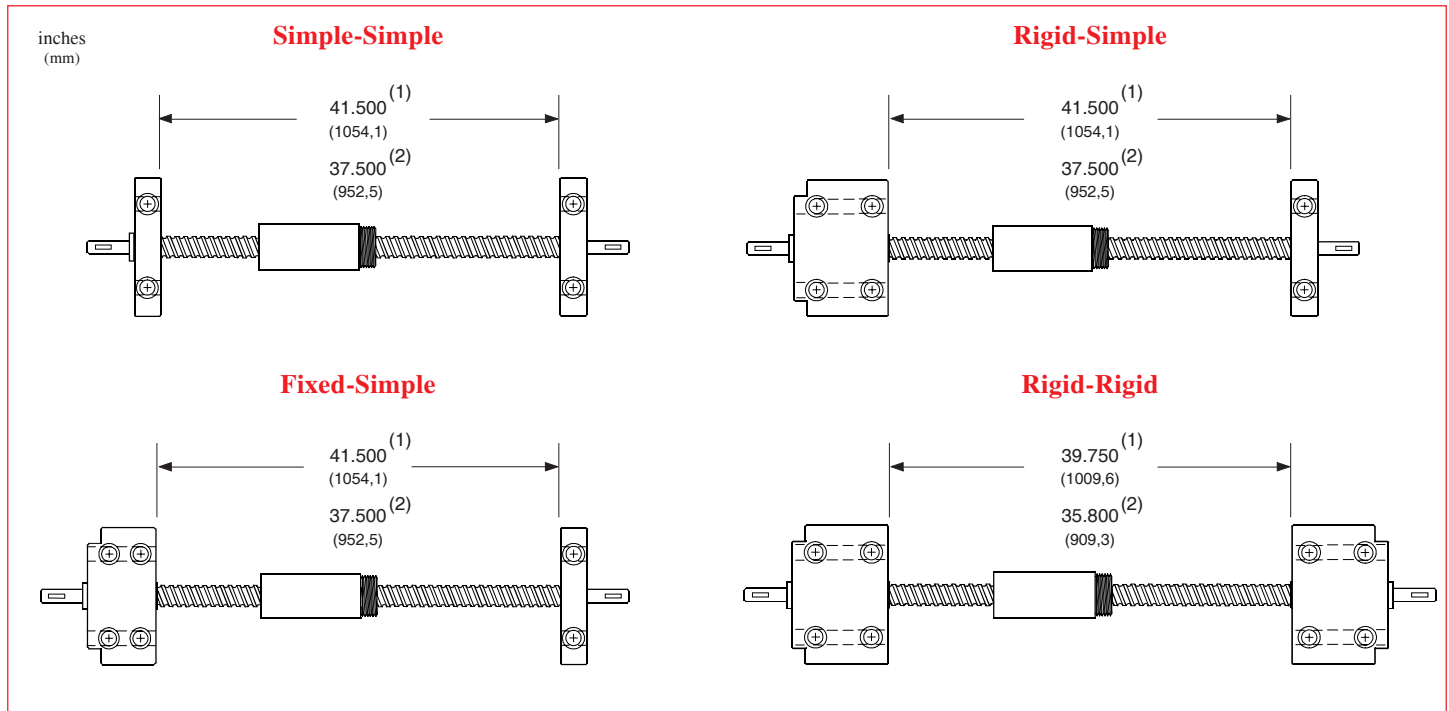

Overall Length Diagram

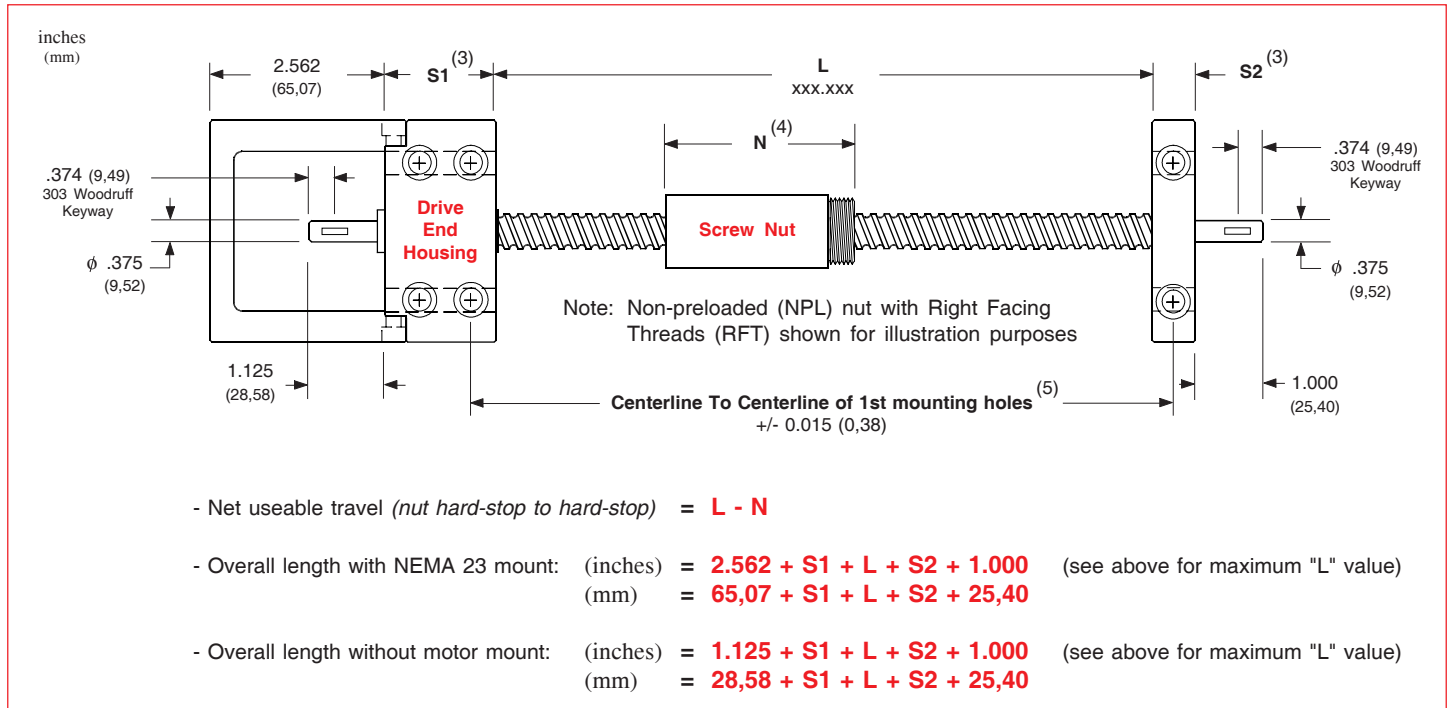

Footnotes:

- (1) Maximum available standard screw thread length (GS062020 series) for the bearing support housing configuration shown.
- (2) Maximum available standard screw thread length (GS16M05M & GS16M16M series) for the bearing support housing configuration shown.
- (3) Fixed-simple support configuration shown for reference. See page 85 for length values for simple, fixed, and rigid housings.
- (4) See page 84 for available nut styles. Refer to A1 & A2 values for the nut length.
- (5) Tolerance shown is for base mounted support housings. Tolerance also applies to face mounted support housings.

Specifications subject to change without notice

Performance Charts

Made in the U.S.A.

Simple-Simple

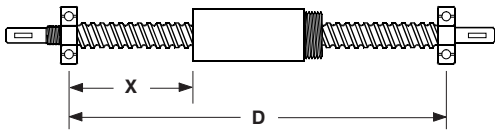

Rigid-Simple

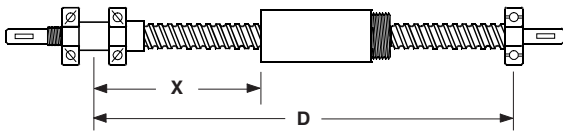

Rigid-Rigid

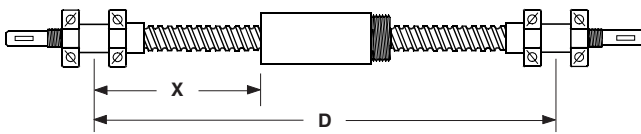

Maximum Compression Load ⁽¹⁾

X inches (mm)	simple-simple		rigid-simple		rigid-rigid	
	lbs	(kgf)	lbs	(kgf)	lbs	(kgf)
20 (508)	1800	(816)	1800	(816)	1800	(816)
30 (1016)	800	(363)	1600	(726)	1800	(816)
40 (1524)	450	(204)	900	(408)	1800	(816)

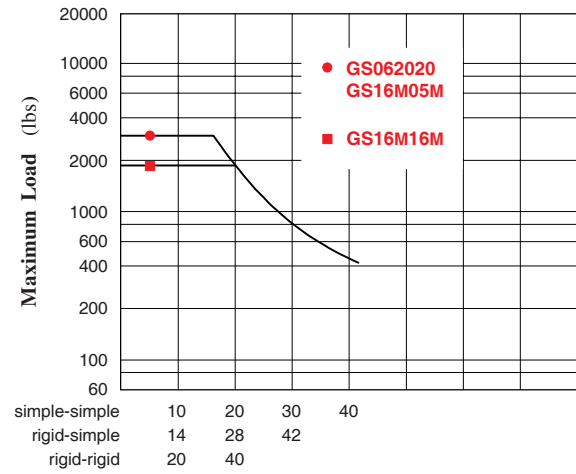

Maximum "X" distance between bearing support and Load (inches)

Maximum Speed ⁽¹⁾

D inches (mm)	simple-simple	rigid-simple	rigid-rigid
	rpm	rpm	rpm
27 (686)	3000	3000	3000
30 (762)	2405	3000	3000
35 (889)	1765	2600	3000
40 (1016)	1350	1985	3000

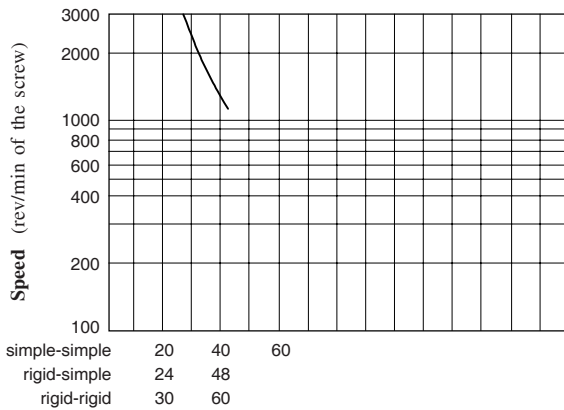

Maximum "D" distance between bearing supports (inches)

Screw Travel Life

Life millions of inches (km)	062020/16M05M		16M16M	
	lbs	(kgf)	lbs	(kgf)
1 (25)	987	(447)	910	(412)
2 (50)	785	(356)	720	(326)
50 (1270)	270	(122)	243	(110)
100 (2540)	216	(97)	199	(90)

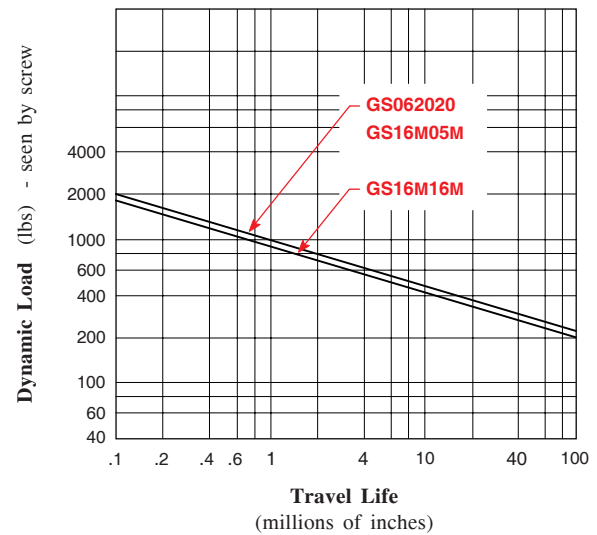

Footnotes:

- (1) Refer to the simple-simple support lengths for fixed-simple configurations. A fixed housing performs like a simple housing for critical speed and compression load specifications.

Nut Dimensions

Made in the U.S.A.

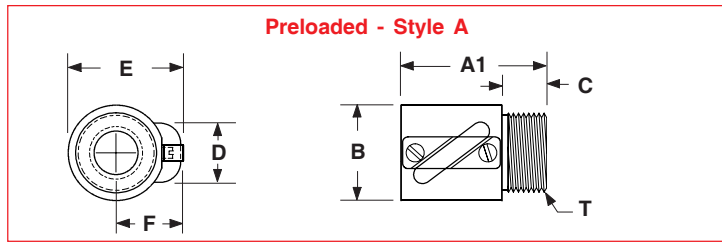

Nut Flange Dimensions

inches (mm)	Round Flange	Vertical Bracket	"L" Bracket
Weight =	0.55 lbs (0,25 kg)	0.35 lbs (0,16 kg)	0.62 lbs (0,28 kg)
	(4) .281 (7,13) Dia. Thru Holes on 2.09 (53,08) Dia. BC	(2) .50 (12,7) Deep Holes English (F2): 1/4-28 thd. Metric (F3): M6 thd.	(4) Holes English (F4): 1/4-28 thd. Metric (F5): M6 thd.
	2.63 (66,80)	1.375 (34,92) 2.125 (53,97)	1.375 (34,92) 2.125 (53,97)
	.500 (12,70)	1.500 (38,10)	1.500 (38,10)
		.750 (19,05) .250 (6,35)	.750 (19,05) .375 (9,52) 1.750 (44,45) .500 (12,70)
		.500 (12,70)	.500 (12,70)

Model Number	Nut Style	Nut Dimensions inches (mm)							Nut (3) Weight lbs (kg)
		A1 (1)	B	C	D	E	F	T - "V" Threads (2)	
GS062020	A	2.090 (53,09)	1.221 (31,00)	0.500 (12,70)	0.847 (21,51)	1.398 (35,51)	0.788 (20,02)	15/16 - 16 UN-2A (23,81 - 16 UN-2A)	0.24 (0,11)
GS16M05M	A	2.090 (53,09)	1.221 (31,00)	0.500 (12,70)	0.847 (21,51)	1.398 (35,51)	0.788 (20,02)	15/16 - 16 UN-2A (23,81 - 16 UN-2A)	0.24 (0,11)
GS16M16M	A	1.890 (48,00)	1.221 (31,00)	0.500 (12,70)	0.847 (21,51)	1.398 (35,51)	0.788 (20,02)	15/16 - 16 UN-2A (23,81 - 16 UN-2A)	0.30 (0,14)

Footnotes:

- (1) The preload is achieved internal to the nut. Thus, the GS series preloaded nut is matched to the screw thread.
- (2) All flange threads are internal (Type 2B) to match the external nut threads.
- (3) Weight of the non-preloaded nut. Multiply value by 2.1 to obtain the weight for the preloaded nut assembly.

Specifications subject to change without notice

Support Housing Dimensions

Made in the U.S.A.

Simple

inches (mm)

.625 (15,87) 2.000 (50,80) (4) .343 (8,71) Dia.Thru Holes

(4) 8-32 x .37 (9,39) Deep on 1.750 (44,45) BC

2.500 (63,50) 1.750 (44,45) 1.250 (31,75)

.375 (9,52) 1.625 (41,27) 3.250 (82,55)

Weight = 1.1 lbs (0,50 kg)

.313 (7,95) (2) .343 (8,71) Dia. Thru Holes, .504 (12,8) Dia. C'Bored x .57 (14,47) Deep

.625 (15,87) .625 (15,87)

Drive End non-Drive End

Fixed

.625 (15,87) 2.000 (50,80) (4) .343 (8,71) Dia.Thru Holes

(4) 8-32 x .37 (9,39) Deep on 1.750 (44,45) BC

2.500 (63,50) 1.750 (44,45) 1.250 (31,75)

.375 (9,52) 1.625 (41,27) 3.250 (82,55) .250 (6,35)

Weight = 2.7 lbs (1,22 kg)

.750 (19,05) .500 (12,70)

(4) .343 (8,71) Dia. Thru Holes, .504 (12,8) Dia. C'Bored x .57 (14,47) Deep

1.125 (28,57)

(2) 10-32 x .43 (10,92) Deep, both sides

.688 (17,47) .125 (3,17) 1.750 (44,45)

Rigid

.625 (15,87) 2.000 (50,80) (4) .343 (8,71) Dia.Thru Holes

(4) 8-32 x .37 (9,39) Deep on 1.750 (44,45) BC

2.500 (63,50) 1.750 (44,45) 1.250 (31,75)

.375 (9,52) 1.625 (41,27) 3.250 (82,55) .250 (6,35)

Weight = 3.9 lbs (1,77 kg)

1.500 (38,10) .500 (12,70)

(4) .343 (8,71) Dia. Thru Holes, .504 (12,8) Dia. C'Bored x .57 (14,47) Deep

1.125 (28,57)

(2) 10-32 x .43 (10,92) Deep, both sides

.688 (17,47) .125 (3,17) 2.500 (63,50)

NEMA 23 Motor Mount

Weight = 0.9 lbs (0,41 kg)

(4) Holes on 2.625 (66,67) BC Dia. English (M02): #10-24 thd. Metric (M03): M5 thd.

1.502 (38,15) Pilot Dia. TYP

2.340 (59,44)

2.562 (65,07) .313 (7,95)

1.437 (36,50)

2.250 (57,15)

1.125 (28,57)

(2) .221 (5,61) Dia.Thru Holes, .344 (8,73) Dia. C'Bored x .125 (3,17) Deep, both sides

NEMA 34 Motor Mount

Weight = 1.4 lbs (0,64 kg)

(4) Holes on 3.875 (98,42) BC Dia. English (M04): #10-24 thd. Metric (M05): M5 thd.

2.877 (73,07) Pilot Dia. TYP

.063 (1,60)

2.340 (59,44)

.500 (12,70) 2.562 (65,07) .313 (7,95)

1.937 (49,20)

3.375 (85,72)

1.688 (42,88)

.438 (11,13)

(2) .221 (5,61) Dia.Thru Holes, .344 (8,73) Dia. C'Bored x .125 (3,17) Deep, both sides

Specifications subject to change without notice

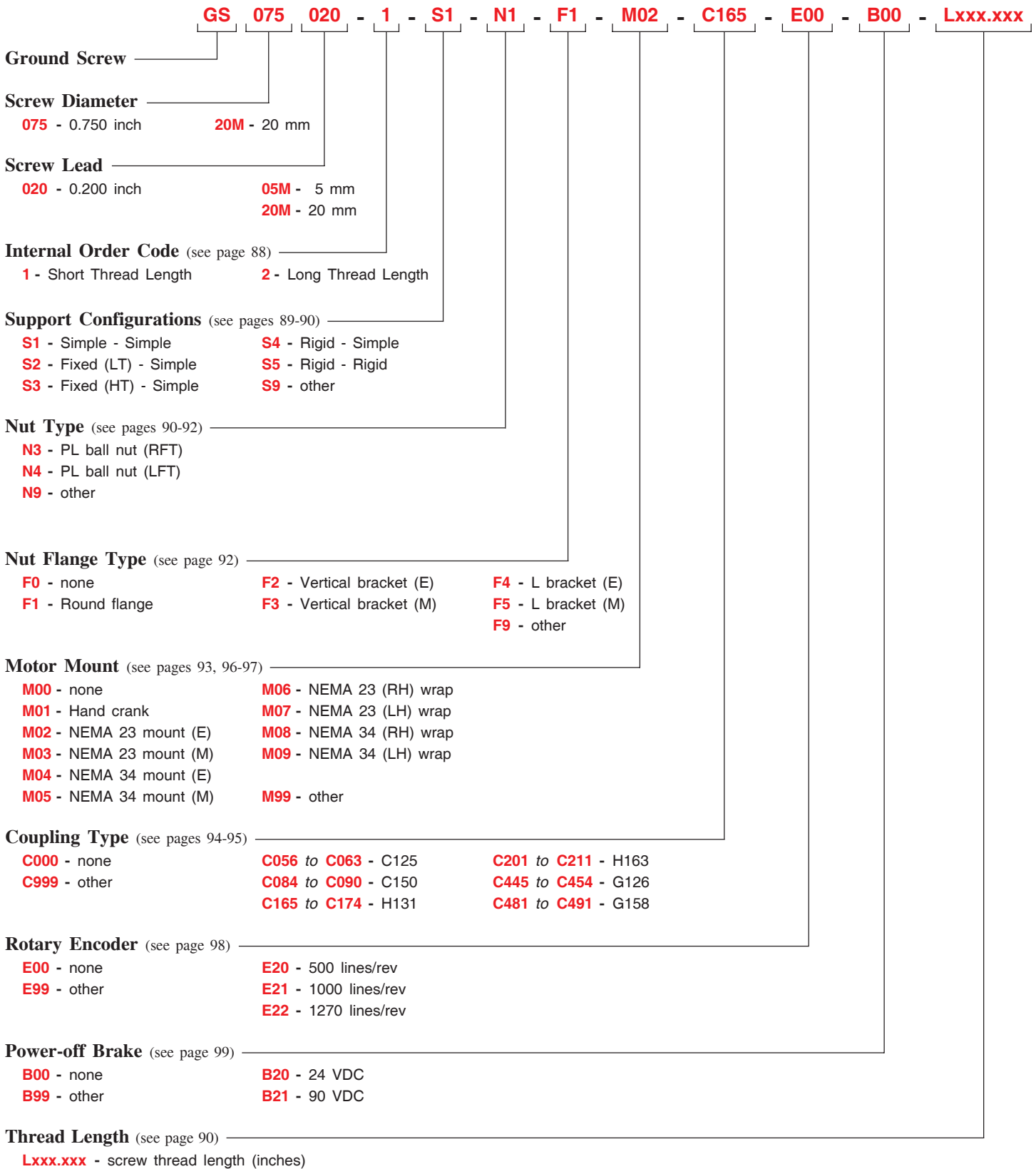

Note: See page 14 for a complete description of the above part number system.

- | | |
|----------------------------|-----------------------------|
| (E) - English Interface | (M) - Metric Interface |
| (LFT) - Left Facing Thread | (NPL) - Non Preloaded |
| (LH) - Left Hand | (PL) - Preloaded |
| (LT) - Low Thrust | (RFT) - Right Facing Thread |
| (HT) - High Thrust | (RH) - Right Hand |

Specifications subject to change without notice

Screw & Nut Specifications

Made in the U.S.A.

Model Number	Nut Type	Diameter inches (mm)	Lead inches (mm)	Root Diameter inches (mm)	Ball Diameter inches (mm)	Number of Circuits	Static Load lbs (kgf)	Dynamic Load ⁽¹⁾ lbs (kgf)
GS075020 0.750 inch dia. 0.200 inch lead	<i>Preloaded</i> Ball (N3/N4)	0.750 (19,05)	0.200 (5,08)	0.635 (16,13)	0.125 (3,17)	1	3,990 (1809)	1,070 (485)
GS20M05M 20 mm dia. 5 mm lead	<i>Preloaded</i> Ball (N3/N4)	0.787 (20,00)	0.196 (5,00)	0.665 (16,89)	0.125 (3,17)	1	3,990 (1809)	1,070 (485)
GS20M20M 20 mm dia. 20 mm lead	<i>Preloaded</i> Ball (N3/N4)	0.787 (20,00)	0.787 (20,00)	0.672 (17,07)	0.125 (3,17)	1	3,505 (1589)	1,293 (586)

Other Specifications

Maximum Acceleration Rate	Ball nut: 772 inches/sec ² (19,6 m/sec ²)
Maximum Speed	Ball nut: 3000 rpm
Screw Material	Right Hand Thread, Case Hardened Rc 58 Steel Ground Ball Screw
Screw Extensions	Woodruff Keyways from Support Housings - 304 Drive End; 303 Opposite End
Screw Maximum Length ⁽²⁾	64.95 inches (1650 mm)
Screw Weight	1.35 lbs/ft (18,7 kg/cm)
Support Housings	Steel with Black Oxide Finish, 45° Chamfer x .02 inch (0,50) all Straight Edges
Support Housing Features	Base or Face Mount with Integral Seals
Nut Flanges	Steel with Black Oxide Finish
Nut Flange Features	English or Metric Load Mounting Interface

Footnotes:

- (1) Load based upon 1 million inches (25 Km) of travel life. See page 91 for further travel life ratings.
 (2) Maximum stock length (not the maximum thread length with bearing housings). See page 90 for maximum thread lengths for each configuration.

TECHNICAL REFERENCE - 0.750 inch & 20 mm screw diameters - GS Series

Screw Specifications

Made in the U.S.A.

Model Number	Nut Type	Screw Efficiency %	Lead Error inch/ft (mm/300 mm)	Backlash inches (mm)	Unidirectional Repeatability inches (mm)	Bidirectional Repeatability inches (mm)
GS075020 0.750 inch dia. 0.200 inch lead & GS20M05M 20 mm dia. 5 mm lead & GS20M20M 20 mm dia. 20 mm lead	<i>Preloaded Ball (N3/N4)</i>	90	< 0.0005 (0,012)	0	+/- 0.0001 (0,0025)	+ 0.0001 to - 0.0001 (0,0025) (0,0025)

Assembly Specifications

Model Number	Nut Type	Breakaway Torque oz-in (N-m)				
		Simple-Simple	Fixed(LT)-Simple	Fixed(HT)-Simple	Rigid-Simple	Rigid-Rigid
GS075020 0.750 inch dia. 0.200 inch lead	<i>Preloaded Ball (N3/N4)</i>	< 20 (0,14)	< 25 (0,18)	< 35 (0,25)	< 35 (0,25)	< 45 (0,32)
GS20M05M 20 mm dia. 5 mm lead	<i>Preloaded Ball (N3/N4)</i>	< 20 (0,14)	< 25 (0,18)	< 35 (0,25)	< 35 (0,25)	< 45 (0,32)
GS20M20M 20 mm dia. 20 mm lead	<i>Preloaded Ball (N3/N4)</i>	< 30 (0,21)	< 35 (0,24)	< 50 (0,35)	< 50 (0,35)	< 60 (0,42)

Internal Order Code

Model Number	Internal Order Code & Support Configuration	Maximum Thread Length "L" inches (mm)	Model Number	Internal Order Code & Support Configuration	Maximum Thread Length "L" inches (mm)
GS075020 0.750 inch dia. 0.200 inch lead & GS20M05M 20 mm dia. 5 mm lead & GS20M20M 20 mm dia. 20 mm lead	-1-S1	29.500 (749,3)	GS075020 0.750 inch dia. 0.200 inch lead & GS20M05M 20 mm dia. 5 mm lead & GS20M20M 20 mm dia. 20 mm lead	-2-S1	61.000 (1549,4)
	-1-S2	29.500 (749,3)		-2-S2	61.000 (1549,4)
	-1-S3	29.500 (749,3)		-2-S3	61.000 (1549,4)
	-1-S4	29.500 (749,3)		-2-S4	61.000 (1549,4)
	-1-S5	27.750 (704,8)		-2-S5	59.250 (1504,9)

Specifications subject to change without notice

Support Housing Specifications

Made in the U.S.A.

Support Housing Life millions of screw revolutions	Support Housing Thrust Load Capacity - (Axial)			
	Simple	Fixed (LT)	Fixed (HT)	Rigid
Static	1,675 (760)	2,110 (957)	3,350 (1520)	3,350 (1520)
1	1,675 (760)	2,110 (957)	3,035 (1377)	3,035 (1377)
2	1,365 (619)	1,720 (780)	2,275 (1032)	2,275 (1032)
10	795 (361)	1,050 (476)	1,375 (624)	1,375 (624)
50	465 (211)	585 (265)	820 (372)	820 (372)
100	370 (168)	465 (211)	650 (295)	650 (295)
500	215 (98)	270 (122)	390 (177)	390 (177)

Thrust force applied in either direction

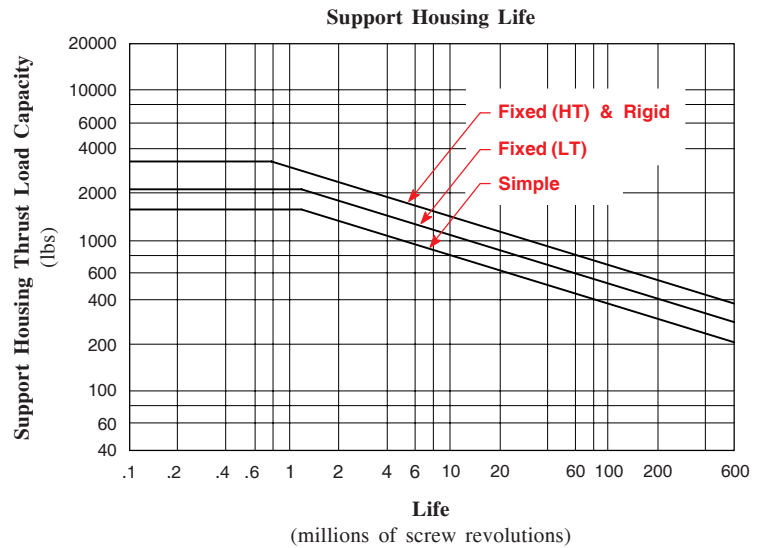
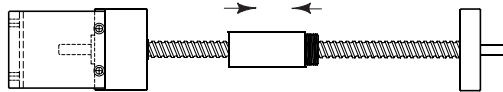

Note: Multiply screw revolutions by the screw lead in order to convert to inches (or mm) traveled by the nut.

Available Configurations

Made in the U.S.A.

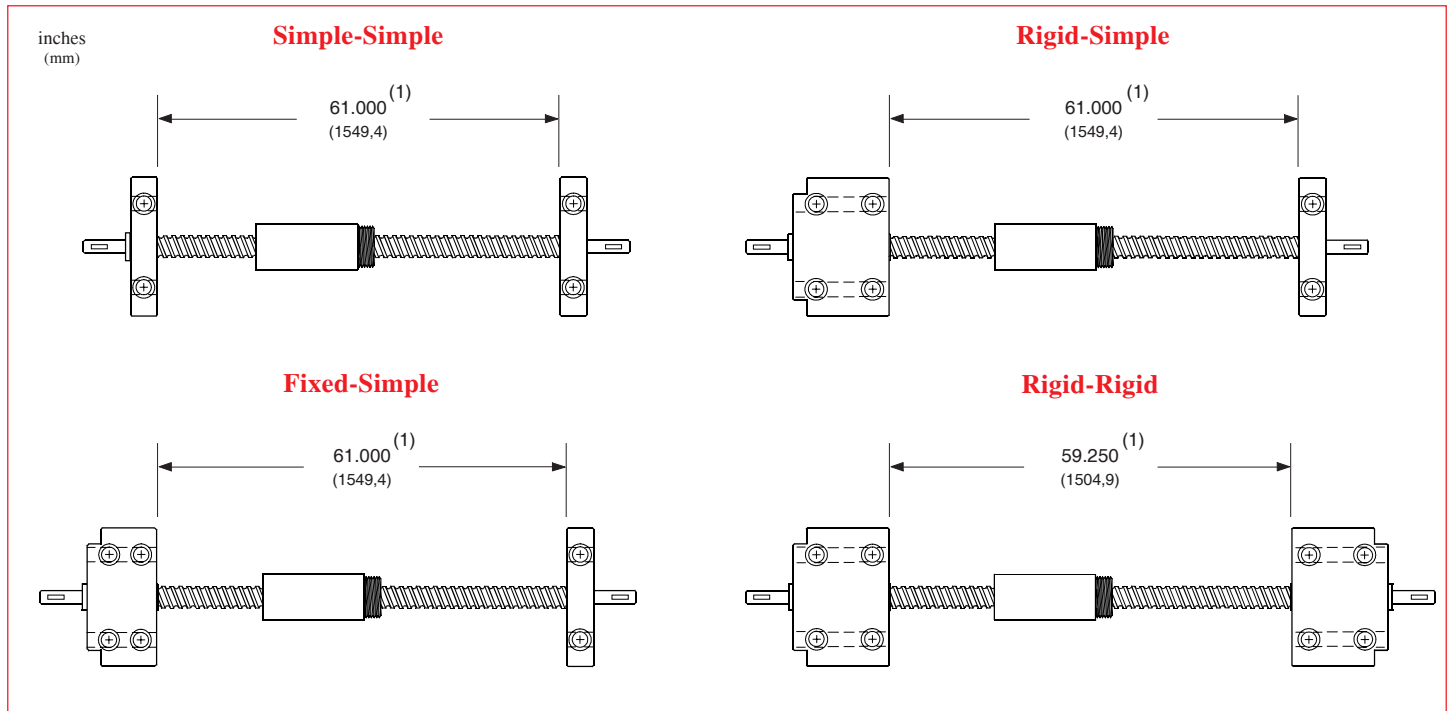

Overall Length Diagram

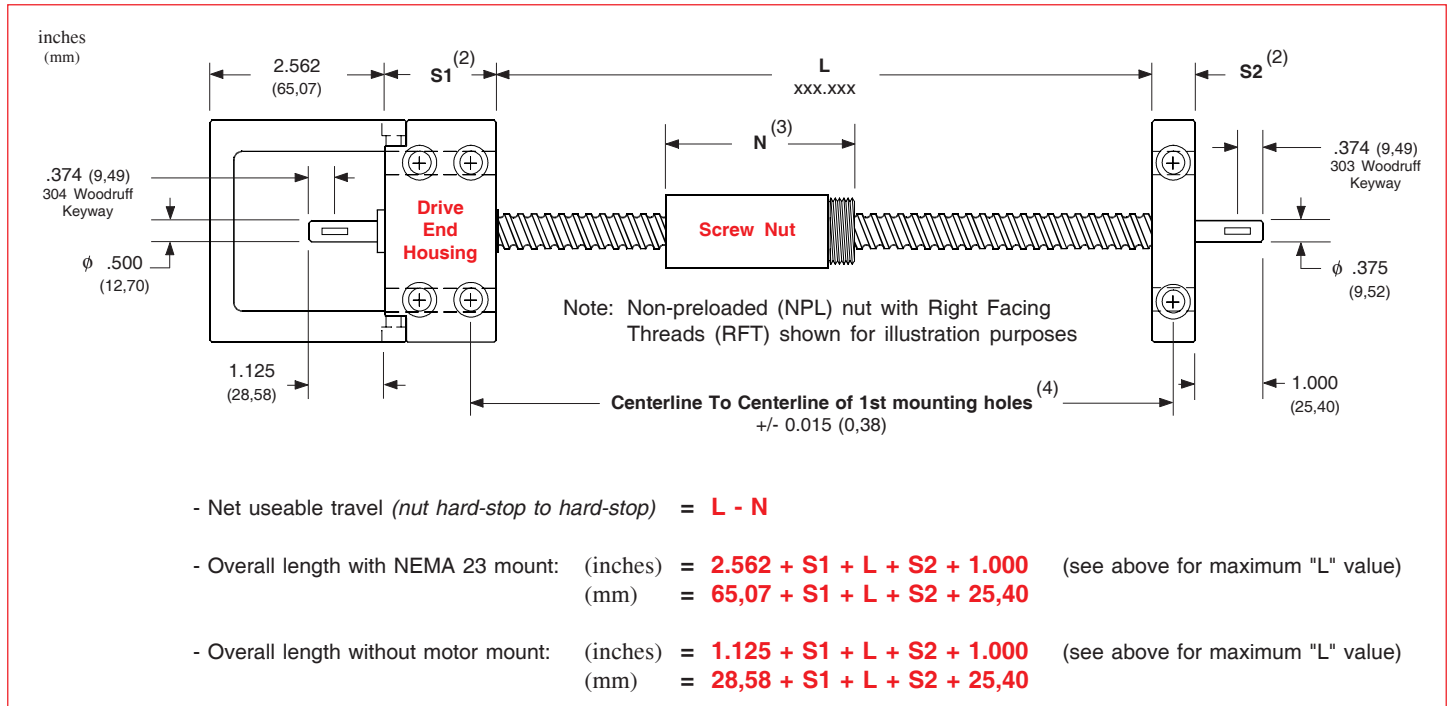

Footnotes:

- (1) Maximum available standard screw thread length for the bearing support housing configuration shown.
- (2) Fixed-simple support configuration shown for reference. See page 93 for length values for simple, fixed, and rigid housings.
- (3) See page 92 for available nut styles. Refer to A1 & A2 values for the nut length.
- (4) Tolerance shown is for base mounted support housings. Tolerance also applies to face mounted support housings.

Performance Charts

Made in the U.S.A.

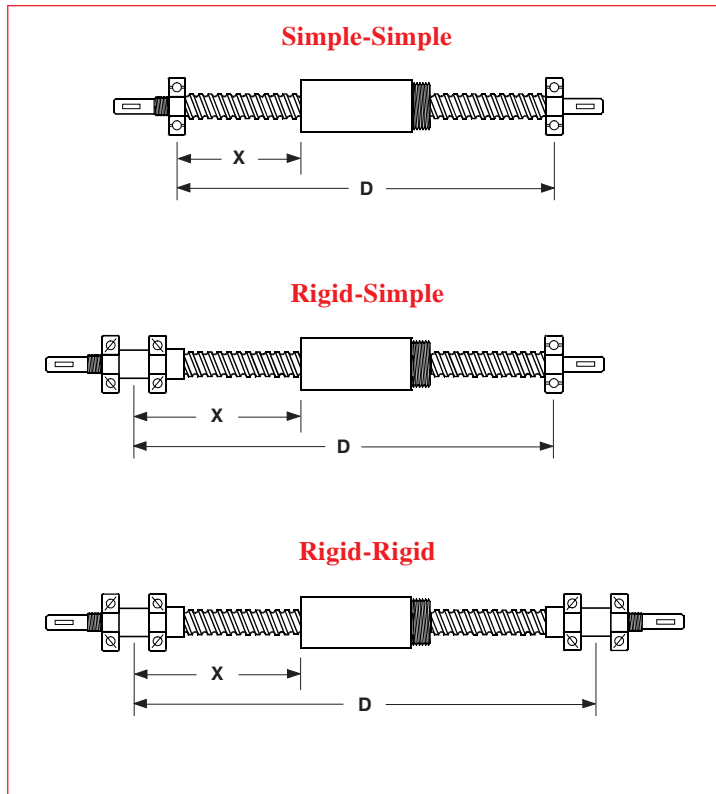

Maximum Compression Load ⁽¹⁾

X inches (mm)	simple-simple		rigid-simple		rigid-rigid	
	lbs	(kgf)	lbs	(kgf)	lbs	(kgf)
20 (508)	3505	(1590)	3505	(1590)	3505	(1590)
40 (1016)	1140	(517)	2020	(916)	3505	(1590)
60 (1524)	505	(229)	1010	(458)	2020	(916)

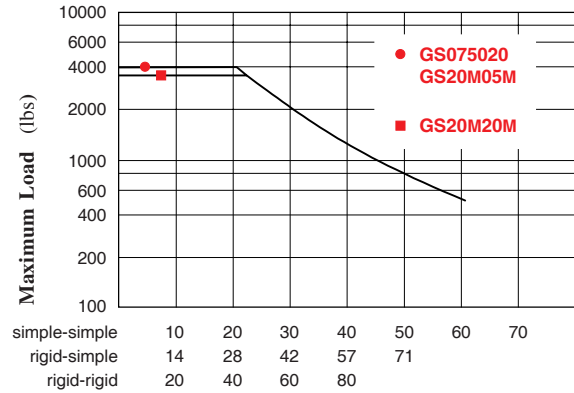

Maximum "X" distance between bearing support and Load (inches)

Maximum Speed ⁽¹⁾

D inches (mm)	simple-simple		rigid-simple		rigid-rigid	
	rpm	rpm	rpm	rpm	rpm	rpm
29 (737)	3000	3000	3000	3000	3000	3000
40 (1016)	1645	2415	2415	2415	3000	3000
50 (1270)	1050	1540	1540	1540	2340	2340
60 (1524)	730	1070	1070	1070	1625	1625

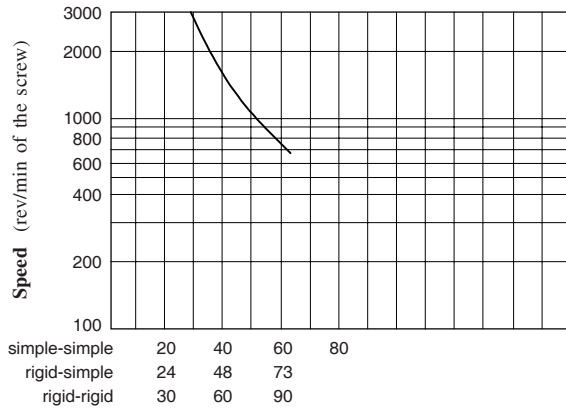

Maximum "D" distance between bearing supports (inches)

Screw Travel Life

Life millions of inches (km)	075020/20M05M		20M20M	
	lbs	(kgf)	lbs	(kgf)
1 (25)	1070	(485)	1293	(586)
2 (50)	850	(385)	1029	(466)
50 (1270)	294	(133)	355	(161)
100 (2540)	234	(106)	283	(128)

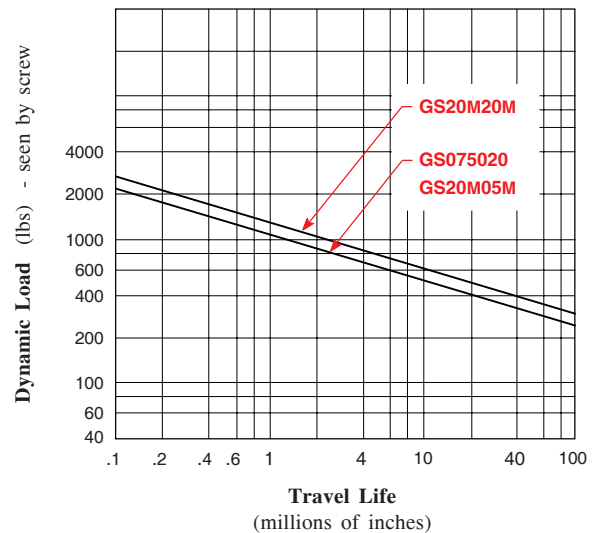

Footnotes:

(1) Refer to the simple-simple support lengths for fixed-simple configurations. A fixed housing performs like a simple housing for critical speed and compression load specifications.

Nut Dimensions

Made in the U.S.A.

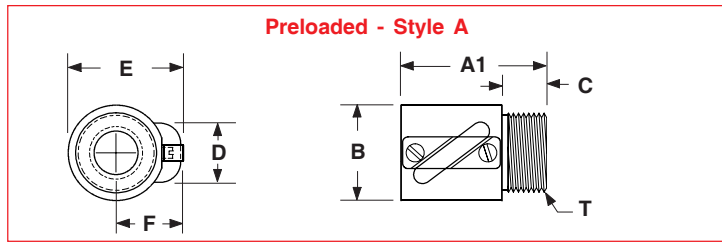

Nut Flange Dimensions

inches (mm)	Round Flange	Vertical Bracket	"L" Bracket
Weight =	0.55 lbs (0,25 kg)	0.31 lbs (0,14 kg)	0.56 lbs (0,25 kg)
	(4) .281 (7,13) Dia. Thru Holes on 2.09 (53,08) Dia. BC	(2) .50 (12,7) Deep Holes English (F2): 1/4-28 thd. Metric (F3): M6 thd.	(4) Holes English (F4): 1/4-28 thd. Metric (F5): M6 thd.
	2.63 (66,80)	1.375 (34,92) 2.250 (57,15)	1.375 (34,92) 2.250 (57,15)
	.500 (12,70)	1.500 (38,10)	1.500 (38,10)
		.750 (19,05) .250 (6,35)	1.250 (31,75) .750 (19,05) 1.000 (25,40)
		.500 (12,70)	.375 (9,52) 2.750 (69,85) .265 (6,73) .500 (12,70)

Model Number	Nut Style	Nut Dimensions inches (mm)							Nut (3) Weight lbs (kg)
		A1 (1)	B	C	D	E	F	T - "V" Threads (2)	
GS075020	A	1.780 (45,21)	1.378 (35,00)	0.500 (12,70)	1.063 (27,00)	1.674 (42,52)	0.985 (25,00)	1.173 - 18 UNS-2A (29,79 - 18 UNS-2A)	0.68 (0,31)
GS20M05M	A	1.780 (45,21)	1.378 (35,00)	0.500 (12,70)	1.063 (27,00)	1.674 (42,52)	0.985 (25,00)	1.173 - 18 UNS-2A (29,79 - 18 UNS-2A)	0.68 (0,31)
GS20M20M	A	2.370 (60,20)	1.418 (36,02)	0.500 (12,70)	1.103 (28,02)	1.772 (45,01)	1.063 (27,00)	1 1/4 - 16 UN-2A (31,75 - 16 UN-2A)	0.85 (0,39)

Footnotes:

- (1) The preload is achieved internal to the nut. Thus, the GS series preloaded nut is matched to the screw thread.
- (2) All flange threads are internal (Type 2B) to match the external nut threads.
- (3) Weight of the non-preloaded nut. Multiply value by 2.1 to obtain the weight for the preloaded nut assembly.

Specifications subject to change without notice

Support Housing Dimensions

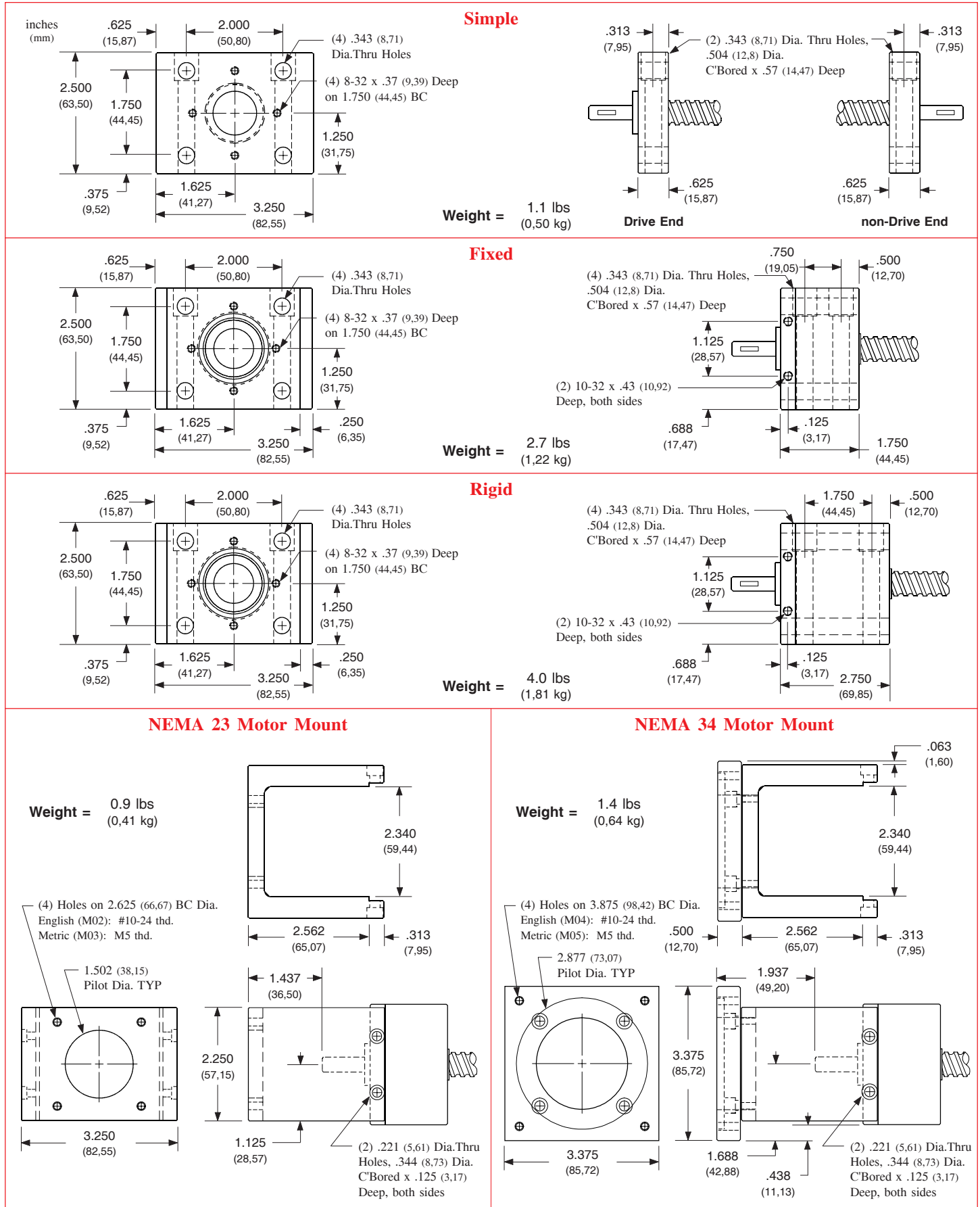

Motor Couplings

LINTECH provides three different types of couplings that can be used to interface a motor to a ball screw assembly. These couplings compensate for some misalignment between the motor shaft & lead screw, or drive shaft extension. This provides for trouble-free operation as long as certain precautions are taken. The connected motor or gearhead output torque should never exceed the coupling maximum torque capacity. Larger capacity couplings may be required for high accelerations, large back driving loads, high torque output motors, servo motors, or gear boxes.

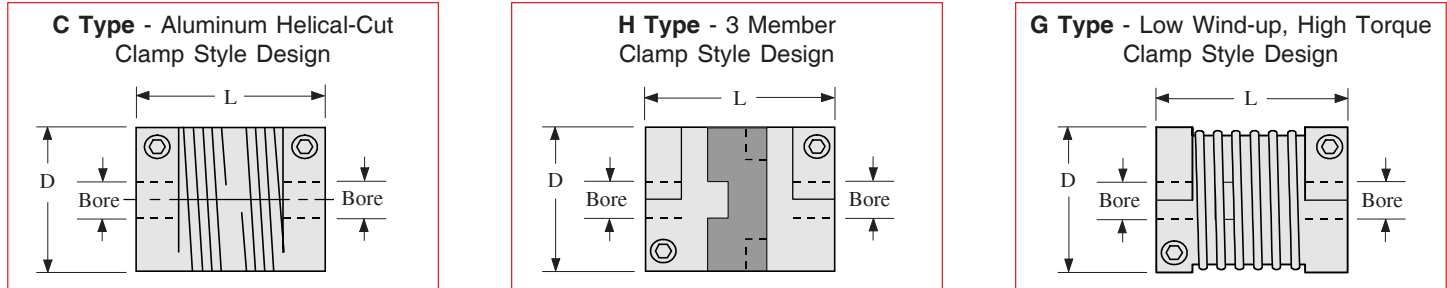

Model #	D inches (mm)	L inches (mm)	Screw	Bore Diameters				Weight ounces (grams)	Inertia oz-in ² (g-cm ²)	Wind-up arc-sec/oz-in (deg/N-m)	Max Torque oz-in (N-m)
				Motor	Minimum (in) (mm)	Maximum (in) (mm)					
C100-xxx-aaa	1.00 (25,4)	1.50 (38,1)	xxx	aaa	.250 6	.375 10	1.5 (43)	.19 (35)	23.0 (0,9)	400 (2,8)	
C125-xxx-aaa	1.25 (31,8)	2.00 (50,8)	xxx	aaa	.250 6	.500 14	3.5 (99)	.68 (124)	15.0 (0,59)	700 (4,9)	
C150-xxx-aaa	1.50 (38,1)	2.37 (60,2)	xxx	aaa	.375 10	.625 16	5.5 (156)	1.54 (282)	13.0 (0,51)	950 (4,9)	
H100-xxx-aaa	1.00 (25,4)	1.28 (32,5)	xxx	aaa	.250 6	.375 10	1.2 (34)	.15 (27)	7.2 (0,28)	450 (2,8)	
H131-xxx-aaa	1.31 (33,3)	1.89 (48,0)	xxx	aaa	.250 6	.625 16	2.9 (82)	.62 (114)	2.5 (0,098)	1,000 (7,1)	
H163-xxx-aaa	1.63 (41,4)	2.00 (50,8)	xxx	aaa	.375 10	.750 20	5.4 (153)	1.79 (328)	1.2 (0,047)	2,000 (14,1)	
H197-xxx-aaa	1.97 (50,0)	2.35 (59,7)	xxx	aaa	.375 10	.750 20	7.6 (215)	3.69 (674)	1.1 (0,043)	3,600 (25,4)	
H225-xxx-aaa	2.25 (57,2)	3.07 (78,0)	xxx	aaa	.500 12	1.000 24	13.1 (371)	8.29 (1516)	0.6 (0,024)	5,300 (37,4)	
G100-xxx-aaa	0.99 (25,2)	1.26 (32,0)	xxx	aaa	.250 6	.500 12	1.3 (36)	.16 (29)	1.0 (0,39)	500 (3,5)	
G126-xxx-aaa	1.26 (32,1)	1.62 (41,0)	xxx	aaa	.250 6	.625 16	2.7 (74)	.54 (99)	0.3 (0,012)	1,100 (7,7)	
G158-xxx-aaa	1.58 (40,2)	1.85 (47,0)	xxx	aaa	.375 10	.750 20	4.3 (120)	1.34 (245)	0.2 (0,008)	2,400 (17,0)	
G177-xxx-aaa	1.77 (45,0)	2.48 (63,0)	xxx	aaa	.375 10	.750 20	7.1 (200)	2.78 (508)	0.2 (0,008)	4,250 (30,0)	
G220-xxx-aaa	2.20 (56,0)	2.56 (65,0)	xxx	aaa	.500 12	1.000 24	10.6 (300)	6.41 (1172)	0.04 (0,002)	7,100 (50,0)	
Possible values for aaa	250 = .250 inch 375 = .375 inch 500 = .500 inch 625 = .625 inch	750 = .750 inch 999 = 1.000 inch			005 = 5 mm 006 = 6 mm 008 = 8 mm 010 = 10 mm	012 = 12 mm 014 = 14 mm 016 = 16 mm 018 = 18 mm	019 = 19 mm 020 = 20 mm 024 = 24 mm				

Specifications subject to change without notice

Motor Couplings

Coupling	Cost	Torque Capacity	Wind-up	Suggested Motor	Comments
C Type	least expensive	light	the most	stepper	ideal for most step motor applications
H Type	medium priced	medium	medium	stepper or servo	use for high accels & for starting & stopping large inertia loads
G Type	most expensive	high	the least	servo	use for very high torque requirements & very high servo accelerations

Specification		Ball Screw Diameters								
		0.500 inch		0.625 inch & 16 mm		0.750 inch & 20 mm		1.000 inch		1.500 inch
		NEMA 23 Mount	NEMA 34 Mount	NEMA 23 Mount	NEMA 34 Mount	NEMA 23 Mount	NEMA 34 Mount	NEMA 34 Mount	NEMA 42 Mount	NEMA 42 Mount
Shaft extension diameter at motor mount end	inches (mm)	.312 (7,92)		.375 (9,52)		.500 (12,70)		.625 (15,87)		.750 (19,05)
Maximum coupling diameter	inches (mm)	2.00 (50,8)	2.00 (50,8)	2.00 (50,8)	2.00 (50,8)	2.00 (50,8)	2.00 (50,8)	3.20 (50,8)	2.80 (71,1)	3.80 (96,5)
Maximum coupling length	inches (mm)	2.10 (53,3)	2.10 (53,3)	2.10 (53,3)	2.10 (53,3)	2.10 (53,3)	2.10 (53,3)	2.60 (66,0)	3.60 (91,4)	3.40 (86,4)

Note: Custom motor mounts available upon request.

C020 C100-312-250	C090 C150-500-016	C171 H131-500-010	C281 H197-750-375	C435 G126-375-250	C492 G158-625-375
C021 C100-312-375	C091 C150-625-375	C172 H131-500-012	C282 H197-750-500	C436 G126-375-375	C493 G158-625-500
C022 C100-312-006	C092 C150-625-500	C173 H131-500-014	C283 H197-750-625	C437 G126-375-500	C494 G158-625-625
C023 C100-312-008	C093 C150-625-625	C174 H131-500-016	C284 H197-750-750	C438 G126-375-625	C495 G158-625-750
C024 C100-312-010	C094 C150-625-010	C175 H131-625-375	C285 H197-750-010	C439 G126-375-006	C496 G158-625-010
C025 C100-375-250	C095 C150-625-012	C176 H131-625-500	C286 H197-750-012	C440 G126-375-008	C497 G158-625-012
C026 C100-375-375	C096 C150-625-014	C177 H131-625-006	C287 H197-750-014	C441 G126-375-010	C498 G158-625-014
C027 C100-375-006	C097 C150-625-016	C178 H131-625-008	C288 H197-750-016	C442 G126-375-012	C499 G158-625-016
C028 C100-375-008	C125 H100-312-250	C179 H131-625-010	C289 H197-750-018	C443 G126-375-014	C500 G158-625-018
C029 C100-375-010	C126 H100-312-375	C180 H131-625-012	C290 H197-750-019	C444 G126-375-016	C501 G158-625-019
C040 C125-312-250	C127 H100-312-006	C181 H131-625-014	C291 H197-750-020	C445 G126-500-250	C502 G158-625-020
C041 C125-312-375	C128 H100-312-008	C182 H131-625-016	C337 H225-750-500	C446 G126-500-375	C503 G158-750-375
C042 C125-312-500	C129 H100-312-010	C201 H163-500-375	C338 H225-750-625	C447 G126-500-500	C504 G158-750-500
C043 C125-312-006	C130 H100-375-250	C202 H163-500-500	C339 H225-750-750	C448 G126-500-625	C505 G158-750-625
C044 C125-312-008	C131 H100-375-375	C203 H163-500-625	C340 H225-750-999	C449 G126-500-006	C506 G158-750-750
C045 C125-312-010	C132 H100-375-006	C204 H163-500-750	C341 H225-750-012	C450 G126-500-008	C507 G158-750-010
C046 C125-312-012	C133 H100-375-008	C205 H163-500-010	C342 H225-750-014	C451 G126-500-010	C508 G158-750-012
C047 C125-312-014	C134 H100-375-010	C206 H163-500-012	C343 H225-750-016	C452 G126-500-012	C509 G158-750-014
C048 C125-375-250	C145 H131-312-250	C207 H163-500-014	C344 H225-750-018	C453 G126-500-014	C510 G158-750-016
C049 C125-375-375	C146 H131-312-375	C208 H163-500-016	C345 H225-750-019	C454 G126-500-016	C511 G158-750-018
C050 C125-375-500	C147 H131-312-500	C209 H163-500-018	C346 H225-750-020	C455 G126-625-375	C512 G158-750-019
C051 C125-375-006	C148 H131-312-625	C210 H163-500-019	C347 H225-750-024	C456 G126-625-500	C513 G158-750-020
C052 C125-375-008	C149 H131-312-006	C211 H163-500-020	C400 G100-312-250	C457 G126-625-625	C561 G177-750-375
C053 C125-375-010	C150 H131-312-008	C212 H163-625-375	C401 G100-312-375	C458 G126-625-008	C562 G177-750-500
C054 C125-375-012	C151 H131-312-010	C213 H163-625-500	C402 G100-312-500	C459 G126-625-010	C563 G177-750-625
C055 C125-375-014	C152 H131-312-012	C214 H163-625-625	C403 G100-312-006	C460 G126-625-012	C564 G177-750-750
C056 C125-500-250	C153 H131-312-014	C215 H163-625-750	C404 G100-312-008	C461 G126-625-014	C565 G177-750-010
C057 C125-500-375	C154 H131-312-016	C216 H163-625-010	C405 G100-312-010	C462 G126-625-016	C566 G177-750-012
C058 C125-500-500	C155 H131-375-250	C217 H163-625-012	C406 G100-312-012	C481 G158-500-375	C567 G177-750-014
C059 C125-500-006	C156 H131-375-375	C218 H163-625-014	C407 G100-375-250	C482 G158-500-500	C568 G177-750-016
C060 C125-500-008	C157 H131-375-500	C219 H163-625-016	C408 G100-375-375	C483 G158-500-625	C569 G177-750-018
C061 C125-500-010	C158 H131-375-625	C220 H163-625-018	C409 G100-375-500	C484 G158-500-750	C570 G177-750-019
C062 C125-500-012	C159 H131-375-006	C221 H163-625-019	C410 G100-375-006	C485 G158-500-010	C571 G177-750-020
C063 C125-500-014	C160 H131-375-008	C222 H163-625-020	C411 G100-375-008	C486 G158-500-012	C617 G220-750-500
C064 C125-625-375	C161 H131-375-010	C223 H163-750-375	C412 G100-375-010	C487 G158-500-014	C618 G220-750-625
C065 C125-625-500	C162 H131-375-012	C224 H163-750-500	C413 G100-375-012	C488 G158-500-016	C619 G220-750-750
C066 C125-625-010	C163 H131-375-014	C225 H163-750-625	C425 G126-312-250	C489 G158-500-018	C620 G220-750-999
C067 C125-625-012	C164 H131-375-016	C226 H163-750-750	C426 G126-312-375	C490 G158-500-019	C621 G220-750-012
C068 C125-625-014	C165 H131-500-250	C227 H163-750-010	C427 G126-312-500	C491 G158-500-020	C622 G220-750-014
C084 C150-500-375	C166 H131-500-375	C228 H163-750-012	C428 G126-312-625	C623 G220-750-016	C624 G220-750-018
C085 C150-500-500	C167 H131-500-500	C229 H163-750-014	C429 G126-312-006	C625 G220-750-019	C626 G220-750-020
C086 C150-500-625	C168 H131-500-625	C230 H163-750-016	C430 G126-312-008	C627 G220-750-024	
C087 C150-500-010	C169 H131-500-006	C231 H163-750-018	C431 G126-312-010		
C088 C150-500-012	C170 H131-500-008	C232 H163-750-019	C432 G126-312-012		
C089 C150-500-014		C233 H163-750-020	C433 G126-312-014		
			C434 G126-312-016		

Specifications subject to change without notice

Hand Crank

For manually operated applications, *LINTECH* provides a hand crank option for 0.500 inch, 0.625 inch, 0.750 inch, 16 mm, and 20 mm diameter screws. If ordered, the hand crank would be installed at the drive end (normally where the motor mount would be).

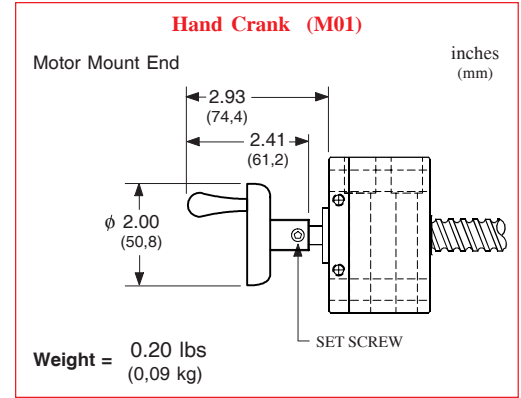

Other Motor Mounts

For motor driven applications, *LINTECH* provides NEMA 23, 34 and 42 motor mounts that easily adapt to either a fixed or rigid bearing housing. For non-NEMA motors, *LINTECH* provides custom motor mounts upon request.

Wiper kits

Wiper kits are only available on the ball nut versions of the RS series assemblies. These brush type wiper kits aid in keeping foreign particles from penetrating the ball nut, and help spread lubricant over the screw as the nut travels back & forth. The wiper kit adds the below lengths to a particular ball nut, thus the overall thread length will increase for a set travel length requirement. Also, one of the nut flange types (F1, F2, F3, F4, or F5) is required to hold the wiper kit in place on the ball nut.

Model Number	A in (mm)	B in (mm)
RS050	.139 (3,53)	.148 (3,76)
RS062	.139 (3,53)	.148 (3,76)
RS075	.158 (4,01)	.148 (3,76)

Model Number	A in (mm)	B in (mm)
RS100	.158 (4,01)	.148 (3,76)
RS150025	.158 (4,01)	.148 (3,76)
RS150050 RS150100 RS150200	0.0 (0,0)	0.0 (0,0)

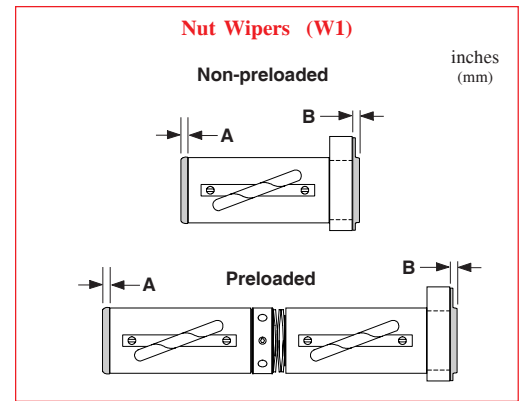

Bellows

Bellows (covers) are available to protect the ball screw & nut from particulates present in the environment. The bellows are designed as a custom fit over the entire length of the screw. Contact the factory for assistance when bellows are required for an application.

Chrome Plated Screw, Nut, Support Housings, and Flange

For applications in high moisture, high humidity, clean room, or highly corrosive environments, chrome plating of the ball screw, ball nut, supports, and flanges will offer superior resistance to corrosion than stainless steel, resulting in longer life. The process uniformly deposits dense, hard, high Chromium alloy on the screw and nut, and has a case hardness value of Rc 67-72. This process also conforms to MIL spec.: (MIL-C-23422). The chrome plating bonds to the parent material and will not crack, chip or peel under load of the balls on the screw. This chrome plating process differs from a normal chrome plate which just lays on the surface of the plated part.

Specifications subject to change without notice

Motor Wrap Packages

For space limited motor driven applications, a belt and pulley system can couple the ball screw to the motor shaft. This wraps the motor parallel to the ball screw assembly in order to decrease the overall ball screw assembly length. Pulley weights and diameters are given in order to assist in calculating motor torque requirements. This option is available only with the fixed and rigid bearing housings and are shown below in the right hand wrap configurations.

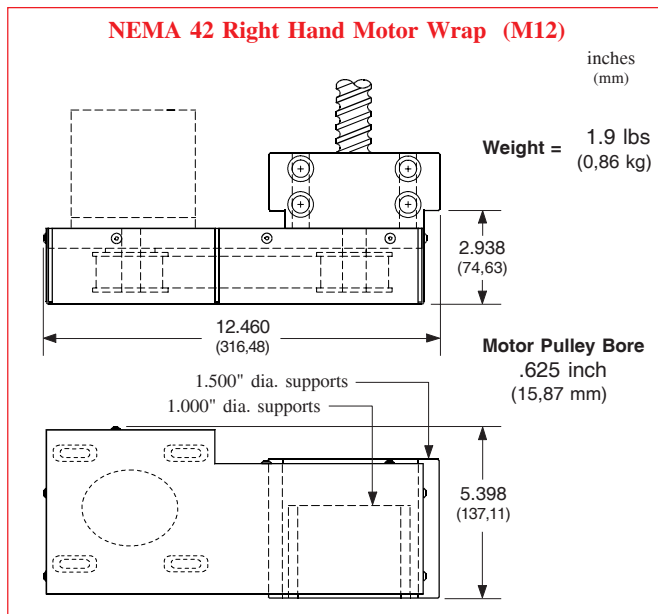
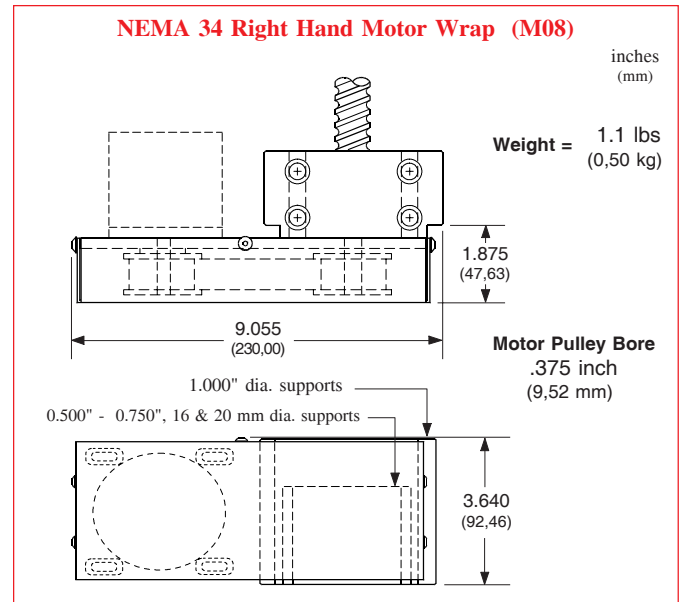
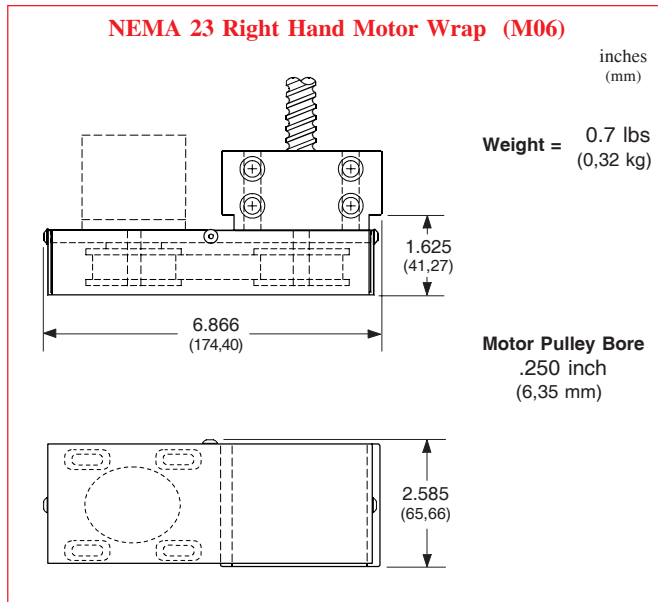

Note: Right hand motor wraps shown. The left hand wrap packages orient the motor to the opposite side of the bearing housing. Motor pulley & belt shipped "loose". No motor mount nuts & bolts are provided. Custom motor wrap packages are available upon request. Other motor pulley bores **MUST** be specified for non-NEMA motors.

Motor Wrap Frame Size	Motor Pulley Dia. inches (mm)	Motor Pulley Weight ounces (kgf)	Screw Pulley Dia. inches (mm)	Screw Pulley Weight ounces (kgf)	Belt Weight ounces (kgf)
NEMA 23	1.65 (41,9)	7.5 (0,21)	1.65 (41,9)	7.5 (0,21)	1.0 (0,028)
NEMA 34	1.65 (41,9)	8.0 (0,23)	1.65 (41,9)	8.0 (0,23)	1.2 (0,034)
NEMA 42	2.12 (53,9)	19.2 (0,54)	2.12 (53,9)	19.2 (0,54)	3.0 (0,085)

Specifications subject to change without notice

Rotary Incremental Encoders

Fully enclosed, shaftless, incremental, optical rotary encoders can be mounted to the screw extension located on the support housing opposite the motor mount end. These encoders are mounted to an adapter plate that is mounted to the face of the housing. An incremental encoder is ideal for providing positional feedback to either a motion controller, or a digital position display.

Specification	ROTARY ENCODERS		
	E20/E24	E21/E25	E22/E26
Line Count	500 lines/rev	1000 lines/rev	1270 lines/rev
Pre Quadrature Resolution	0.002 revs/pulse	0.001 revs/pulse	0.00079 revs/pulse
Post Quadrature Resolution	0.0005 revs/pulse	0.00025 revs/pulse	0.00019 revs/pulse
Maximum Speed	60 revs/sec		
Maximum Accel	4 G's		
Excitation Power	+ 5 VDC @ 125 ma		
Operating Temperature	32° F to 230° F (0° C to 100° C)		
Humidity	20% to 98% non condensing		
Shock	50 G's for 11 msec duration		
Weight	4.5 ounces		
Cable Length	10 ft (3 m), unterminated 26 gauge leads		
Zero Reference Output	Once per revolution		
Outputs	TTL square wave; Two channel (A+ & B+); Differential (A- & B-); Line Driver		

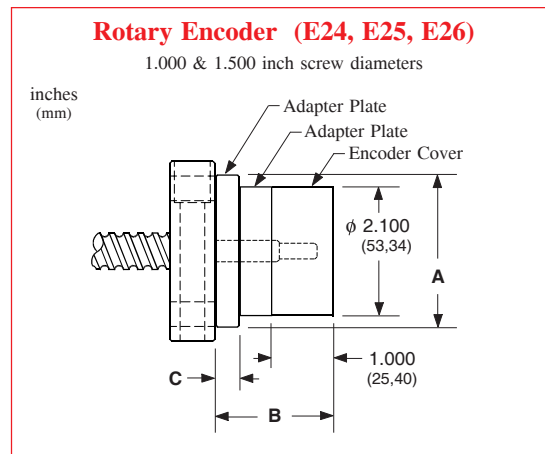
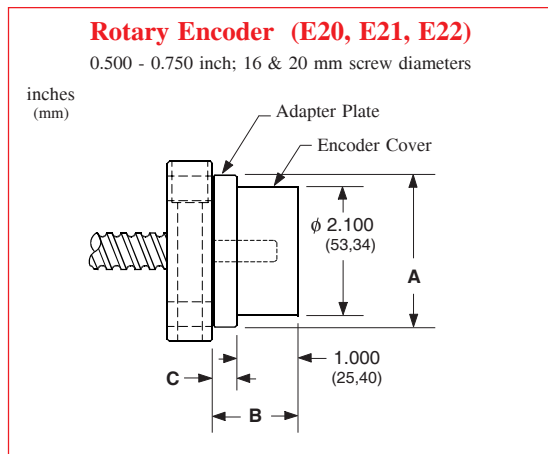

Wire Color	Description
White	Channel A+ (or A)
Blue	Channel A- (or \bar{A})
Green	Channel B+ (or B)
Orange	Channel B- (or \bar{B})
White/Black	Channel Z+ (or Z)
Red/Black	Channel Z- (or \bar{Z})
Black	Common
Red	+ 5 vdc (+/- 5%)

Screw Diameters	Encoder Version	A in (mm)	B in (mm)	C in (mm)	Weight lbs (kgf)
0.500 to 0.750 inch 16 & 20 mm	E20, E21 & E22	2.500 (63,50)	1.375 (34,92)	0.375 (9,52)	1.0 (0,45)
1.000 inch	E24, E25 & E26	3.500 (88,90)	2.200 (55,88)	0.500 (12,70)	1.4 (0,63)
1.500 inch	E24, E25 & E26	4.250 (107,95)	2.425 (61,59)	0.625 (15,87)	1.6 (0,73)

Specifications subject to change without notice

Power-off Electric Brakes

For vertical applications, or for those applications requiring the load to be locked securely in place, an electric brake may be mounted to the ball screw assembly. The RS, PS, GS series can have the brake mounted to the screw extension located on the support housing opposite the motor mount end. This power-off friction brake ensures the ball screw is firmly held in place when no electric power is applied. This prevents the ball screw from rotating. When power is applied to the brake, the brake is opened or "released", thus, allowing rotation of the screw. For proper emergency holding of the ball screw, this electric brake needs to be interfaced to a position controller or relay network. *LINTECH* also provides 24 & 90 VDC power supplies which can be used to power the brakes.

Screw Diameters	Brake Version	Holding Force	Excitation Voltage	Current
		in-lbs (N-m)	volts	amps
0.500 to 0.750 inch 16 & 20 mm	B20	18 (2,03)	24 VDC	0.733
	B21	18 (2,03)	90 VDC	0.178
1.000 inch	B22	84 (9,49)	24 VDC	0.973
	B23	84 (9,49)	90 VDC	0.239
1.500 inch	B24	180 (20,3)	24 VDC	1.136
	B25	180 (20,3)	90 VDC	0.287

Note: This power-off electric brake MUST NOT be engaged when the ball screw is in motion. Moving the screw with the brake applied could damage the brake and the ball screw assembly. Also, continuous use of this brake to stop the load that is in motion could damage the brake and the ball screw assembly. Dynamic braking of a ball screw assembly should be done by the motor and not the brake.

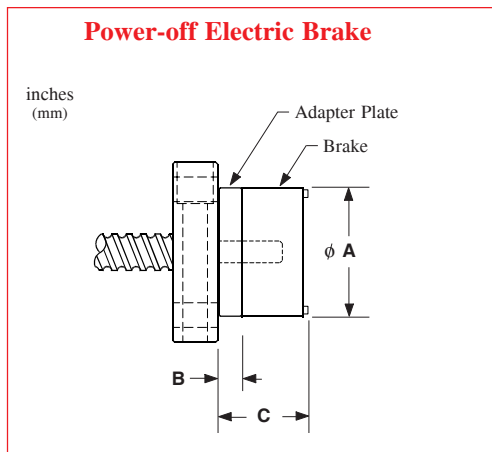

Screw Diameters	Brake Version	A in (mm)	B in (mm)	C in (mm)	Weight lbs (kgf)
0.500 to 0.750 inch 16 & 20 mm	B20 & B21	2.460 (62,48)	0.375 (9,52)	2.125 (53,97)	1.7 (0,77)
1.000 inch	B22 & B23	3.520 (89,41)	0.500 (12,70)	2.350 (59,69)	4.1 (1,86)
1.500 inch	B24 & B25	4.270 (108,46)	0.625 (15,87)	2.650 (67,31)	5.5 (2,49)

Power Supplies

Model Number	DC Output			AC Input		
	volts	amps	style	volts	amps	Hz
41970	5	3.0	regulated	120 / 240	0.8 / 0.4	47-63
37488	24	1.2	regulated	120 / 240	0.8 / 0.4	47-63
37489	90	0.8	unregulated	120	1.0	50/60
37490	90	0.8	unregulated	240	0.5	50/60

UNIT CONVERSIONS

Torque Conversions

Present Units	Convert To	Multiply By
Gram-centimeters	newton-meters -----	0.0000981
Gram-centimeters	ounce-inches -----	0.0138874
Gram-centimeters	pound-inches -----	0.000868
Gram-centimeters	pound-feet -----	0.0000723
Newton-meters	gram-centimeters ----	10,197.162
Newton-meters	ounce-inches -----	141.612
Newton-meters	pound-inches -----	8.85
Newton-meters	pound-feet -----	0.73756
Ounce-inches	gram-centimeters ----	72.0077
Ounce-inches	newton-meters -----	0.007062
Ounce-inches	pound-inches -----	0.0625
Ounce-inches	pound-feet -----	0.005208
Pound-inches	gram-centimeters ----	1,152.0
Pound-inches	newton-meters -----	0.11299
Pound-inches	ounce-inches -----	16.0
Pound-inches	pound-feet -----	0.08333
Pound-feet	gram-centimeters ----	13,825.5
Pound-feet	newton-meters -----	1.3558
Pound-feet	ounce-inches -----	192.0
Pound-feet	pound-inches -----	12.0

Distance Conversions

Present Units	Convert To	Multiply By
Arc-minutes	degrees -----	0.016666
Arc-seconds	degrees -----	0.000277
Centimeters	inches -----	0.3937
Centimeters	feet -----	0.03280
Centimeters	microns -----	10,000.0
Degrees	arc-minutes ----	60.0
Degrees	arc-seconds ----	3,600.0
Degrees	radians -----	0.017453
Feet	centimeters ----	30.48
Feet	meters -----	0.3048
Inches	centimeters ----	2.54
Inches	Km -----	0.0000254
Inches	meters -----	0.0254
Inches	microns -----	25,400.0
Inches	millimeters ----	25.4
Km	inches -----	39,370.0
Meters	feet -----	3.2808
Meters	inches -----	39.37
Meters	microns -----	1,000,000.0
Microns	centimeters ----	0.0001
Microns	inches -----	0.00003937
Microns	meters -----	0.000001
Microns	millimeters ----	0.001
Millimeters	inches -----	0.03937
Millimeters	microns -----	1,000.0
Radians	degrees -----	57.295779

Inertia Conversions

Present Units	Convert To	Multiply By
Gram-cm ²	ounce-inches ² ----	0.00546745
Gram-cm ²	ounce-inch-sec ² --	0.000014161
Gram-cm ²	pound-inches ² ----	0.000341716
Gram-cm ²	pound-inch-sec ² --	0.000000885
Gram-cm ²	pound-feet-sec ² --	0.000000074
Ounce-inches ²	gram-cm ² -----	182.901
Ounce-inches ²	ounce-inch-sec ² --	0.00259008
Ounce-inches ²	pound-inches ² ----	0.0625
Ounce-inches ²	pound-inch-sec ² --	0.00016188
Ounce-inches ²	pound-feet-sec ² --	0.00001349
Ounce-inch-sec ²	gram-cm ² -----	70,615.4
Ounce-inch-sec ²	ounce-inches ² ----	386.0
Ounce-inch-sec ²	pound-inches ² ----	24.13045
Ounce-inch-sec ²	pound-inch-sec ² --	0.0625
Ounce-inch-sec ²	pound-feet-sec ² --	0.00520833
Pound-inches ²	gram-cm ² -----	2,926.41
Pound-inches ²	ounce-inches ² ----	16.0
Pound-inches ²	ounce-inch-sec ² --	0.0414413
Pound-inches ²	pound-inch-sec ² --	0.00259008
Pound-inches ²	pound-feet-sec ² --	0.00021584
Pound-inch-sec ²	gram-cm ² -----	1,129,850.0
Pound-inch-sec ²	ounce-inches ² ----	6,177.4
Pound-inch-sec ²	ounce-inch-sec ² --	16.0
Pound-inch-sec ²	pound-inches ² ----	386.0
Pound-inch-sec ²	pound-feet-sec ² --	0.0833333
Pound-feet-sec ²	gram-cm ² -----	13,558,200.0
Pound-feet-sec ²	ounce-inches ² ----	74,128.9
Pound-feet-sec ²	ounce-inch-sec ² --	192.0
Pound-feet-sec ²	pound-inches ² ----	4,633.06
Pound-feet-sec ²	pound-inch-sec ² --	12.0

Load Conversions

Present Units	Convert To	Multiply By
Grams	newtons -----	0.009806
Grams	ounces -----	0.03528
Grams	pounds -----	0.002204
Kilograms	pounds -----	2.2046
Newtons	grams -----	101.971
Newtons	ounces -----	3.59692
Newtons	pounds -----	0.224808
Ounces	grams -----	28.3495
Ounces	newtons -----	0.27802
Ounces	pounds -----	0.0625
Pounds	grams -----	453.592
Pounds	kilograms -----	0.45359
Pounds	newtons -----	4.44824
Pounds	ounces -----	16.0
Pounds	tons -----	0.0005
Tons	pounds -----	2,000.0

TERMS OF SALE

To Order

Any standard ball screw assembly in this catalog may be ordered by mail, phone, or fax from an Automation Specialist in your area. To obtain the name of your local Automation Specialist call:

LINTECH®

1845 Enterprise Way
Monrovia, CA 91016

Toll Free: (800) 435 - 7494

Phone: (626) 358 - 0110

Fax: (626) 303 - 2035

Web Site: www.LintechMotion.com

E-Mail: Lintech@LintechMotion.com

All required options should be reviewed using the part numbering guide for each model series. Your local Automation Specialist or factory engineer can assist you with any questions you may have.

Delivery

All shipping promises are made in good faith. Any shipping dates appearing on acknowledgments of orders, or given to a customer in any other manner are approximate. Where the customer delays in supplying information necessary to proceeding with an order, the date of shipment may be extended accordingly. Standard products shown in this catalog are usually available for delivery within 2 to 6 weeks of receipt of a purchase order. However, component shortages, labor disputes, or any other unforeseen circumstance may delay the delivery of an order. *LINTECH* shall not be held liable under any circumstance. All products are shipped F.O.B. Monrovia, CA. *LINTECH* packages all standard and custom products carefully. However, *LINTECH* is not liable for damage incurred during shipment. Contact the carrier immediately if damage to a package or shipment is noticed upon receipt of such shipment.

Terms

Unless otherwise specified, standard terms of credit are net thirty (30) days from date of invoice, providing satisfactory credit is established with *LINTECH* or one of its Automation Specialists. No responsibility is assumed by *LINTECH* for damages arising from delivery delays, fires, strikes, material shortages, accidents, or any other cause whatsoever, and purchase orders are accepted subject only to these conditions irrespective of statements or stipulations on purchase orders.

Warranty

All *LINTECH* ball screw assemblies are guaranteed to be free from defects in material and workmanship, under normal use, for a period of one year after date of shipment. This warranty covers the repair or replacement of a product when it is sent prepaid to *LINTECH*. *LINTECH* does not assume liability for installation, abuse, alteration, insufficient application data provided for a design, or misuse of any positioning system. Products furnished by *LINTECH*, but not manufactured by *LINTECH* (motors, encoders, amplifiers, etc....), are subject to the manufacturer's standard warranty terms and conditions.

Returns

Any product requiring a return to *LINTECH* (for warranty or non-warranty repair) requires pre-approval from the factory prior to shipment. Contact the customer service department at (800) 435-7494 in order to obtain a RMA (Return Materials Authorization) number. At that time, please have your system Model & Serial numbers available, along with the reason for the return. The RMA number should be clearly marked on the returned package label and your packing list, or shipping document. Return product freight prepaid in its original package, or one with comparable protection. *LINTECH* will not accept return shipments sent freight collect. Product damage incurred during return shipment, from poor packaging, will not be warranted by *LINTECH*. Keeping original packing materials is recommended until initial inspection & testing is completed.

Dimensions and Product Changes

Published dimensions shown in this catalog are known to be accurate at time of printing. *LINTECH* shall not be held liable, under any circumstances, for any wrongly documented dimension or specification. Changes in design are made whenever *LINTECH* believes its products will improve by the change. No obligation to incorporate these changes in units manufactured prior to a change, will be assumed.

Cancellations

All items entered for production and on which a cancellation is requested, shall be paid for on the basis of actual cost of labor, materials and supplies applied to the production of such items plus proper overhead expenses determined in accordance with good accounting practice, plus 25% of the total of such cost and expenses; provided that such cost and expense plus 25% shall in no case exceed 100% of the quoted price of original order. Upon cancellation, *LINTECH* may dispose of materials used in the manufacture of cancelled order as it sees fit.



Positioning Components

LINTECH shaft assembly products provide solutions to many linear motion applications. Single and *TWIN RAIL*® shaft assemblies are provided from 0.500 to 2.00 inch (12 to 50mm) diameters, in lengths up to 192 inches (4875 mm). *TWIN RAIL*® carriage assemblies easily adapt to the *TWIN RAIL*® shaft assemblies for a complete transport system.

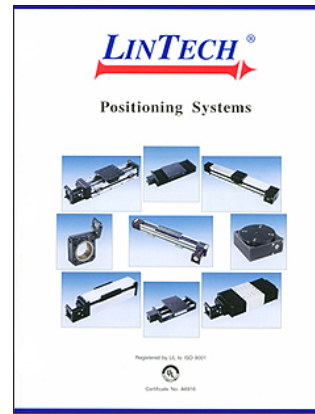

Positioning Systems

LINTECH provides 15 different linear & rotary standard positioning systems to choose from. These belt, screw, and worm gear driven systems can handle load capacities from 10 pounds (11 kg) to 16,600 pounds (7530 kg) and are available with numerous options. Custom systems are also available.



1845 Enterprise Way
Monrovia, CA. 91016
(800) 435 - 7494
(626) 358 - 0110
Fax: (626) 303 - 2035

Web Site: www.LintechMotion.com
E-Mail: Lintech@LintechMotion.com

YOUR LOCAL AUTOMATION SPECIALIST:

