

Optional programming header

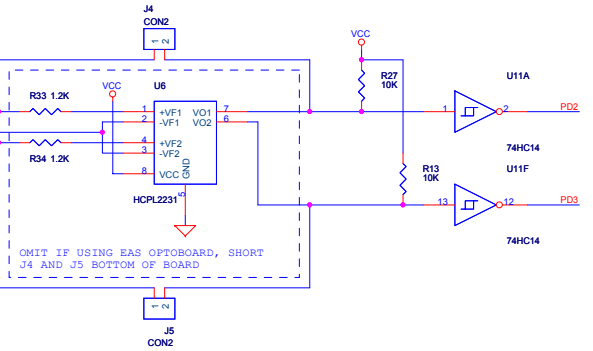
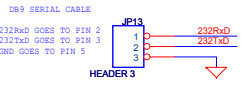
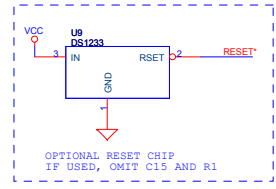

.1 Ohm 5 Watt
 one 7 ampere maximum current through servo motor.
 two 14 ampere maximum current
 three 21 ampere maximum current
 four 28 ampere maximum current
 five 35 ampere maximum current

Note: Other optos that have worked HCPL2631

Note: For all 1N4007 diodes a better choice is to use MUR120 or HERR105 as fast switching Diodes

Embedded Acquisition Systems
 2571 Cobden Dr.
 Sterling Heights, MI 48310
 WEB <http://www.embeddedelectronics.com>
 Copyright 2007

Based on Uli Uber's design
<http://www.uhu-servo.de/>
 NewsGroup
<http://www.cnczone.com/forums/showthread.php?t=14217>

Title		UHU BASED SERVO CONTROLLER	
Size	C	Document Number	<Doc>
Date:	Tuesday, July 10, 2007	Sheet	1 of 1