

OneCNC

2000 Series

Manufacturing Software

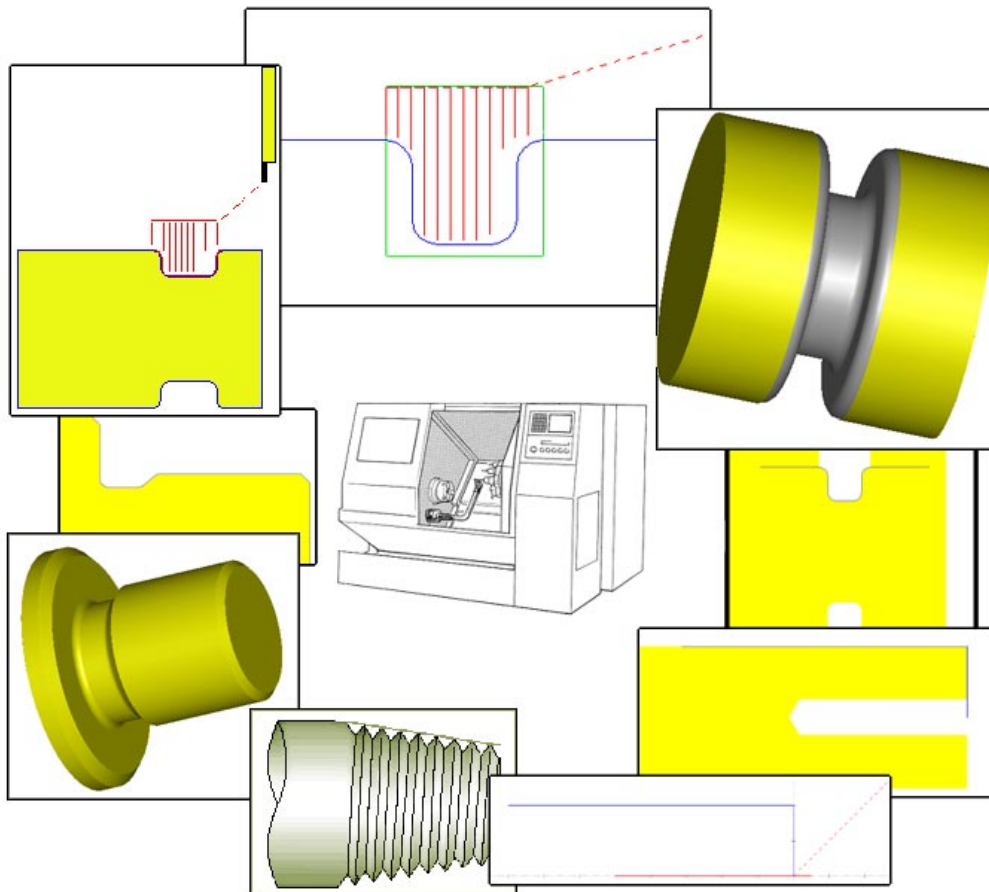

Tutorials

For Lathe

Contents

<i>Tutorial</i>	<i>Page</i>
Use Lathe Turn Face Function	3
Use Lathe Thread Function	18
Use Lathe Groove Function	26
Use Lathe Drill Function	39
Use Lathe Part Off Function	43

USA

OneCNC LLC

Phone: 1-727-7243988
Fax: 1-727-7240025

Email: support@onecnc.com
Internet: www.onecnc.com

Australia

QARM Pty Ltd

Phone: 617 32862527
Fax: 617 32864992

Email: support@qarm.com.au
Internet: www.qarm.com.au

Version 1.02

(rev 28-6-01)

Lathe Tutorial 1

Use Lathe Turn Face Function

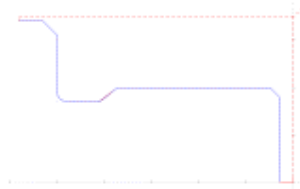

Note: This help uses mm values.

This is a tutorial to draw a 2D part using OneCNC Lathe then rough turn it, then apply a finish cut and simulate the NC code.

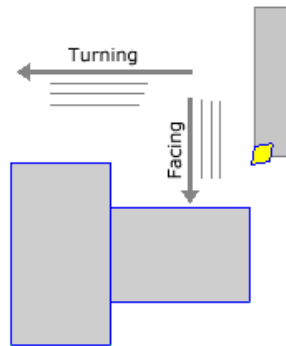

Step 1. Create a New Drawing

 Click the **new drawing icon** on the **standard toolbar**.

You should have a blank drawing ready to draw.

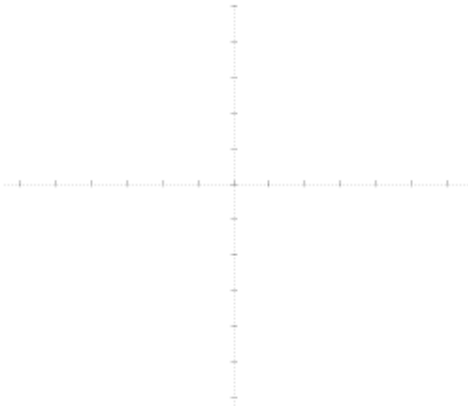

Now to make sure the NC file is clear

 Click the **new NC icon** on the **NC editor toolbar**.

Click **Yes** or **No** to save your file.

Step 2. Create a Part

 Click the **line icon** on the **standard toolbar**.

 Click the **line by coordinates** icon on the **line menu toolbar**.

Enter the following values and click **OK**.



Then enter the next coordinates and click **OK**



Then enter the next coordinates and click **OK**.

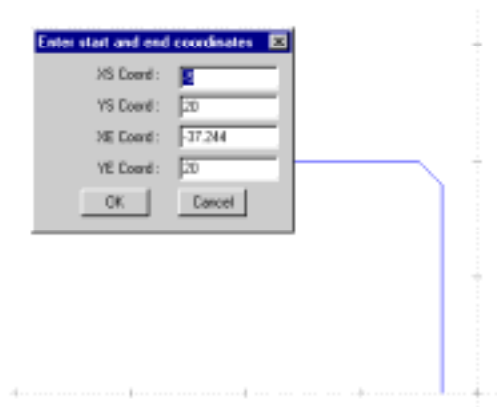

Then enter the next coordinates and click **OK**.



Then enter the next coordinates and click **OK**.



Then enter the next coordinates and click **OK**.



Step 3. Chamfer the Lines

 Click the **chamfer icon** on the **line menu toolbar**.

Select **this line** with the mouse and click the **left mouse button**.



Then click this second line with the **left mouse button**.

Then enter the values for a chamfer and click **OK**.



The chamfer is then created.

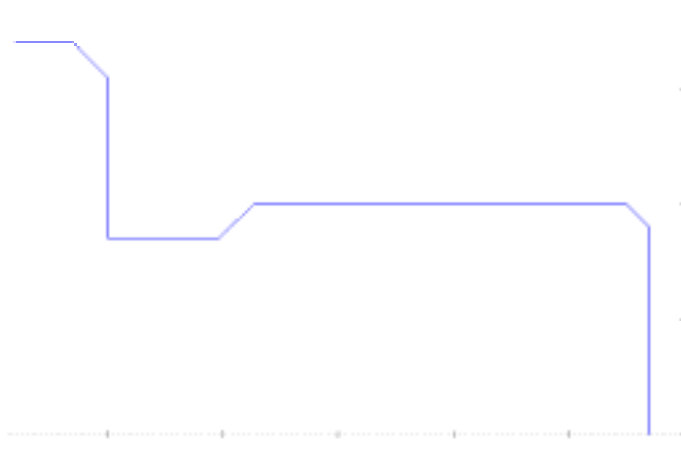

Step 4. Fillet the Lines



Click the **home icon** on the **menu toolbar**.



Click the **arc and spline icon** on the **menu toolbar**.



Click the **fillet icon** on the **arc and spline menu toolbar**.

Select the first line then the second line enter the fillet value and click OK.

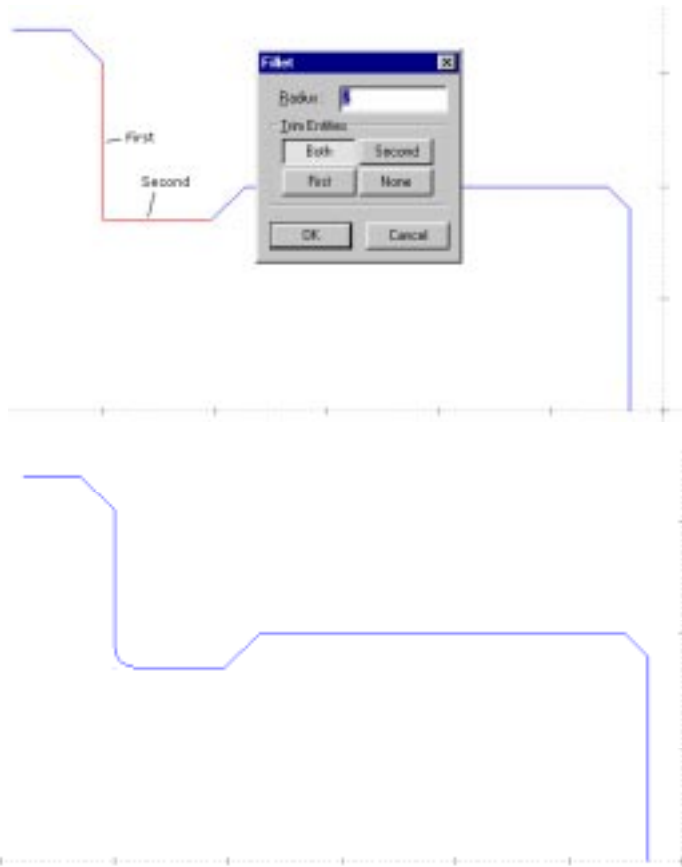

Click the **fillet icon** on the **arc and spline menu toolbar**.

Pick the first line then the second line, enter the fillet radius and click **OK**.

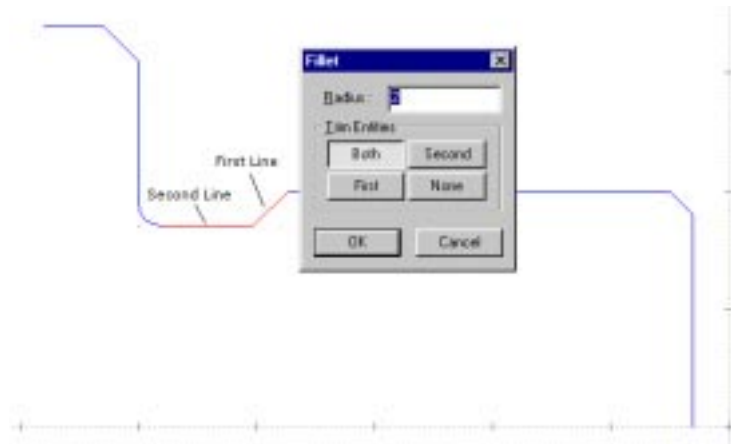

The drawing is now completed.

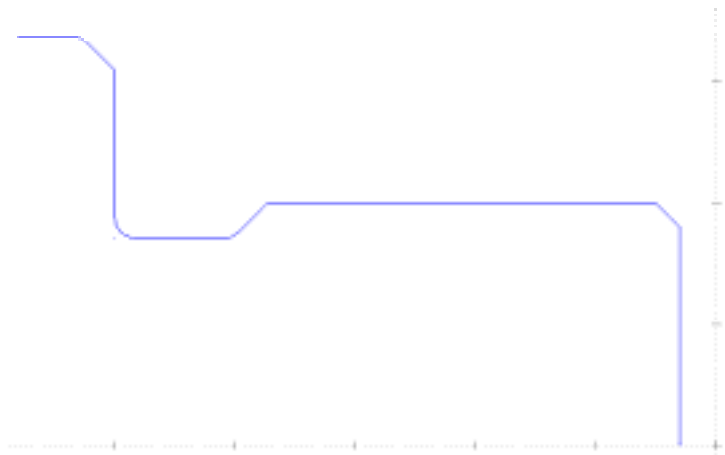

Step 5. Rendering the Part

This now ready to machine.

You will notice that we have only had to draw half the shape above the centerline as for a lathe program that is all that is required.



Click the **render** icon on the **standard toolbar**.

Then click the **start line** and point the arrow up like so.



Then click the **end line** the last one on the top.

Then click the **right mouse button** to complete the selection.

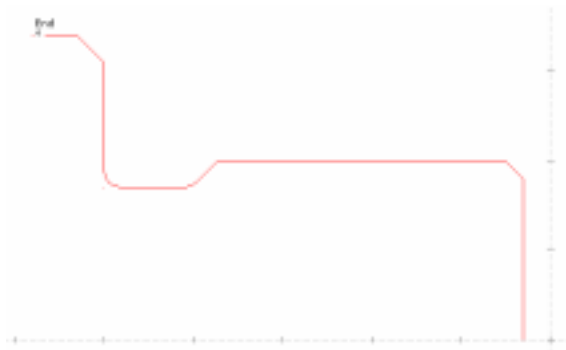

The rendered model is then shown.

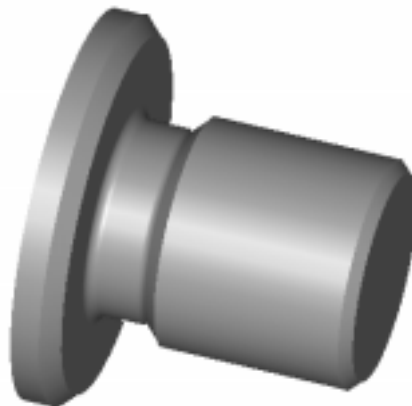

Step 6. Roughing the Part

To rough turn this part.



Click the **turn and face roughing icon** on the **NC CAM toolbar**.

The following dialogue will appear for you to select the required tool.

After you have selected your tool click **next**.

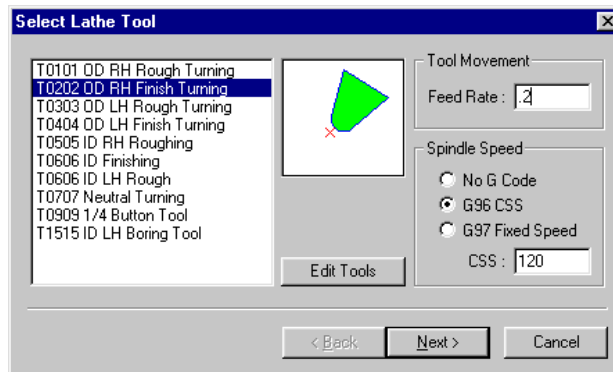

Then select the **boundary method** and the **X and Z clearance**.

After you complete this click **next**.

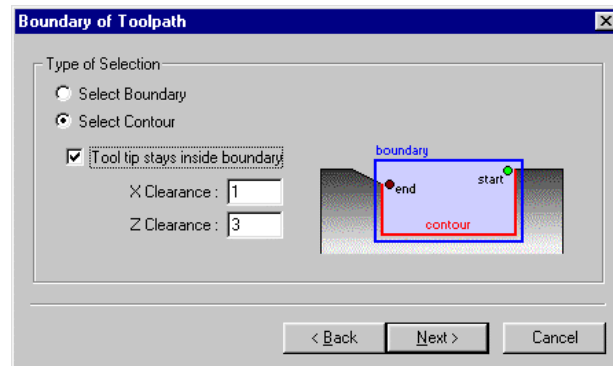

Now select longitudinal cut direction, set the finish allowances and the cut depth.

Then click **finish**.

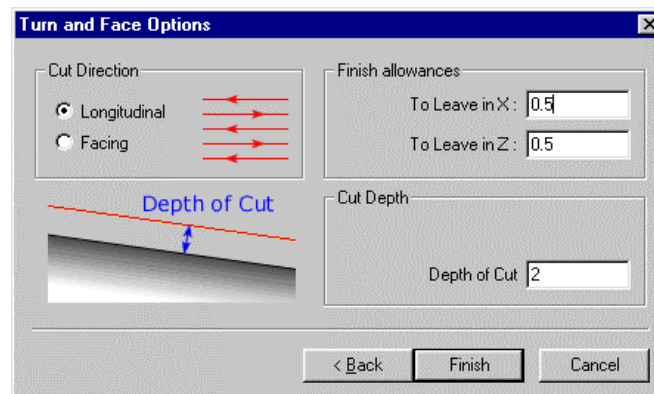

Then select the **start of the profile** and point the arrow in this direction like so.

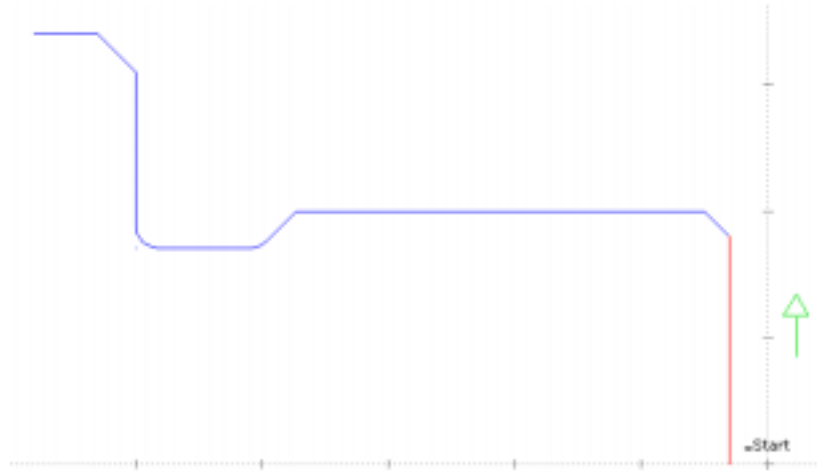

Then select the **end of the profile**, then click the **right mouse button** to end the selection

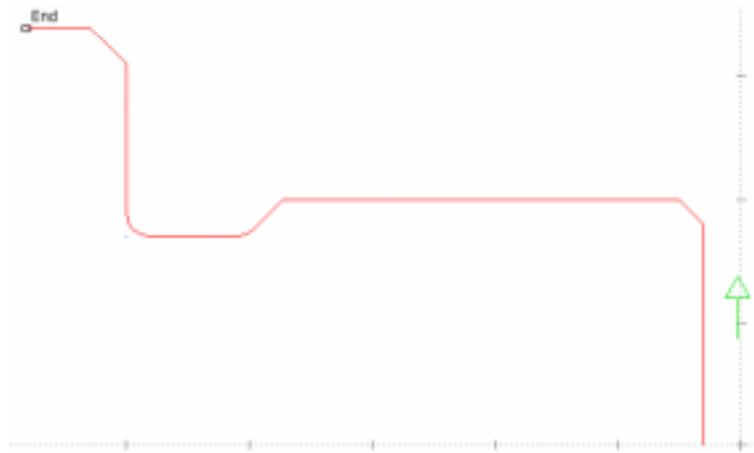

You will then be asked "Is offset and direction OK", click **Yes**.

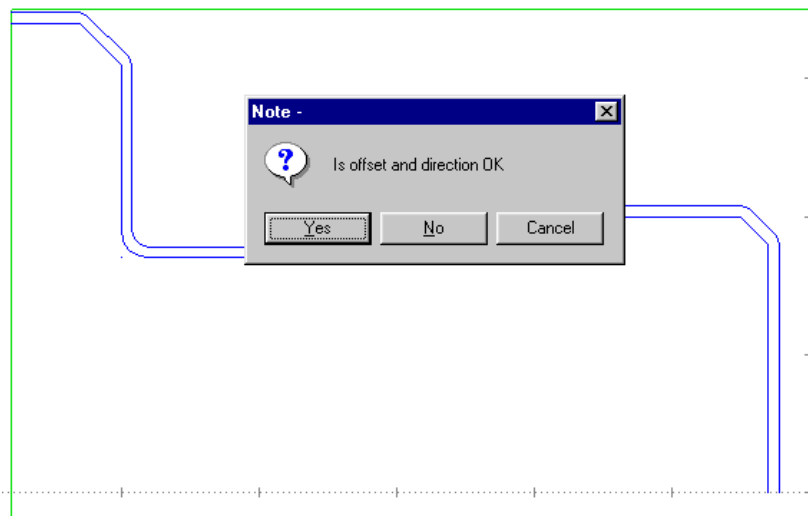

The roughing code is then created.

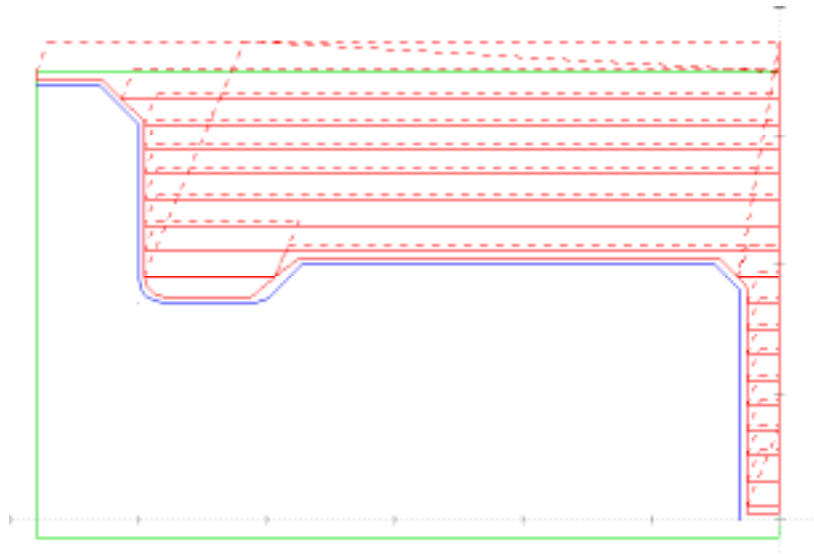

Click the **lathe simulation icon** on the **NC CAM toolbar**.

The following dialogue will appear, click **OK**.

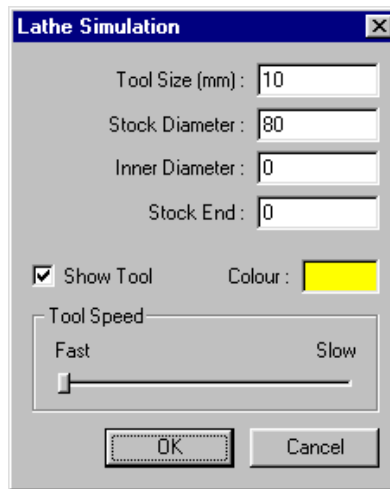

The NC file is now simulated.



Step 7. Finishing the Part

We will now create a finishing toolpath for this part.



Click the **turn and face finishing** icon on the **NC CAM** toolbar.

Click the run a finish cut over profile icon .

The following tool selection dialogue appears.

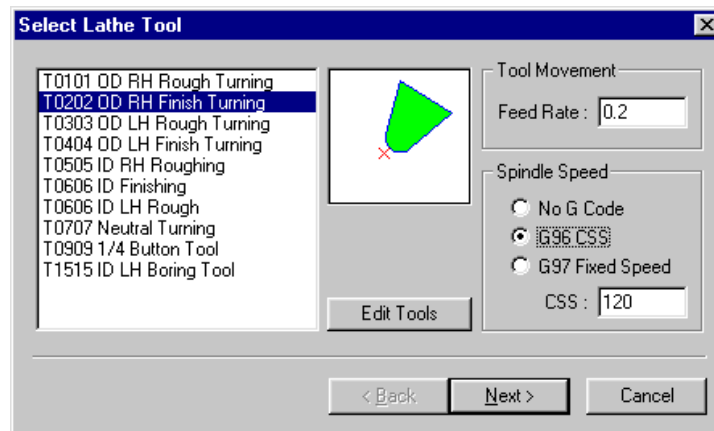

Select a **finish tool** then click **next**.

Then set your **approach clearance** and **boundary**.

Then click **next**.

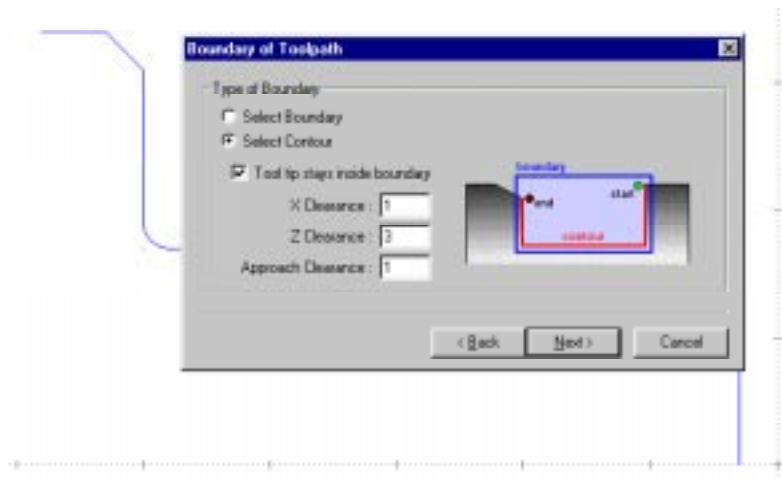

Select your number of **finish cuts**, **cut direction** and **compensation**.

Then click **finish**.

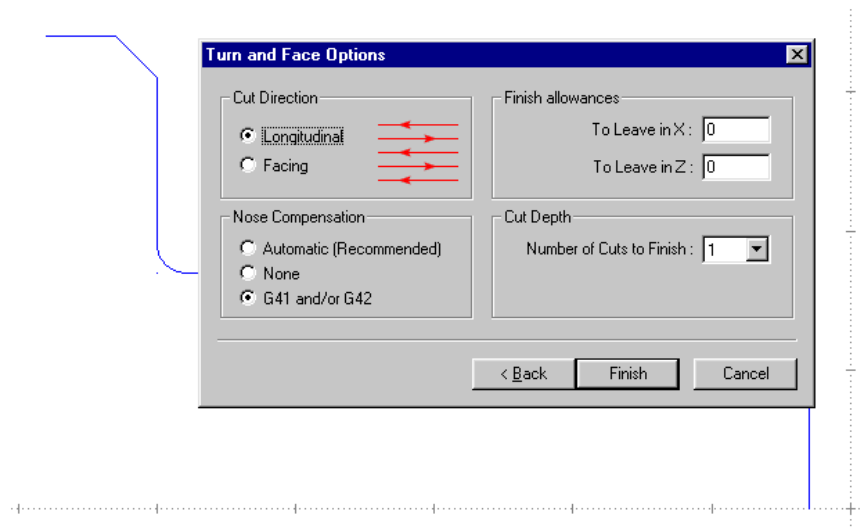

Select the **start of the profile** and point the arrow in the direction of the cut and click the **left mouse button**.

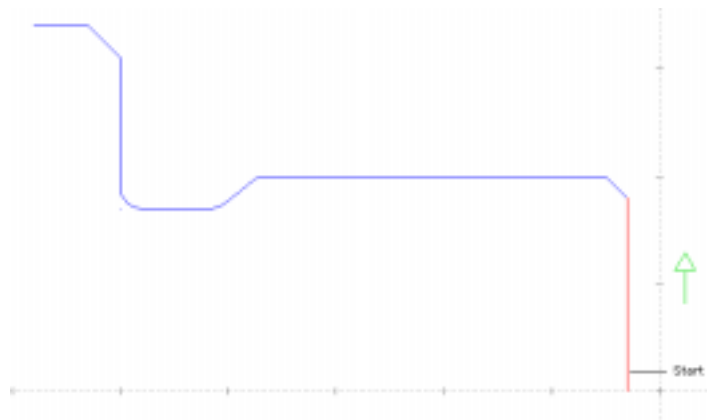

Then select the **end of the profile** with the mouse and **left mouse button** and then click the **right mouse button** to complete the selection.

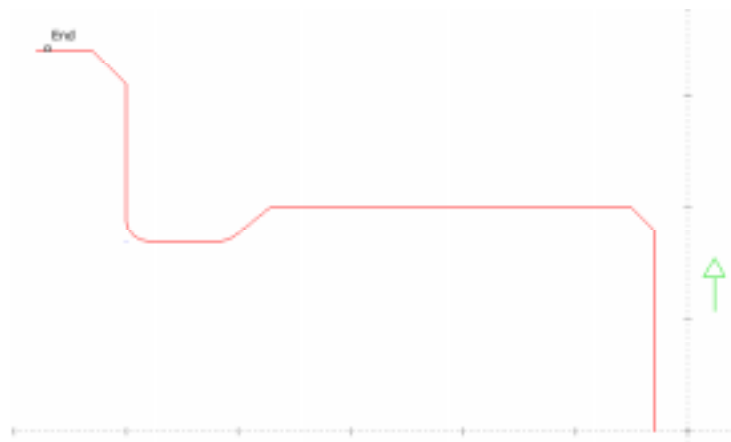

You will be then asked if it offset to the correct side of the profile.

Click **yes**.

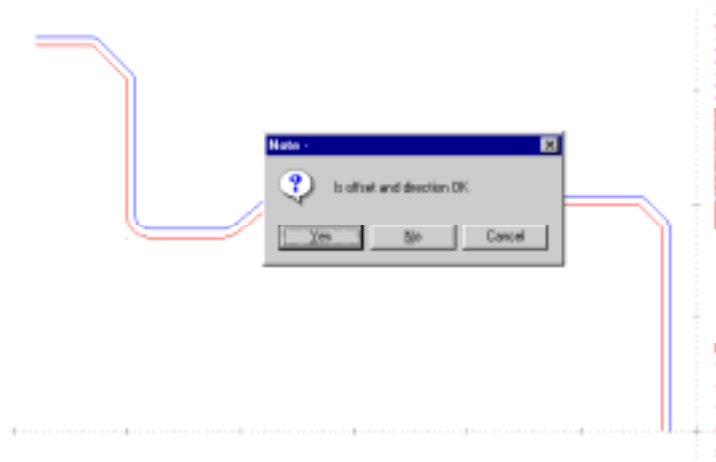

The finish profile is then created.

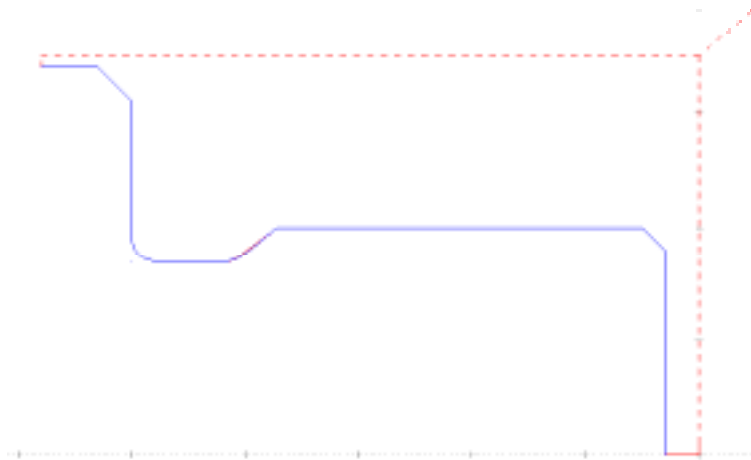

Click the **lathe simulation icon** on the **NC CAM toolbar**.

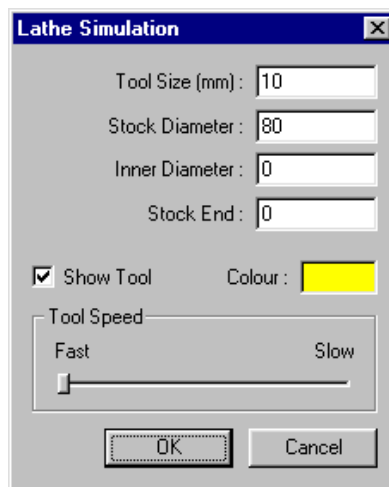

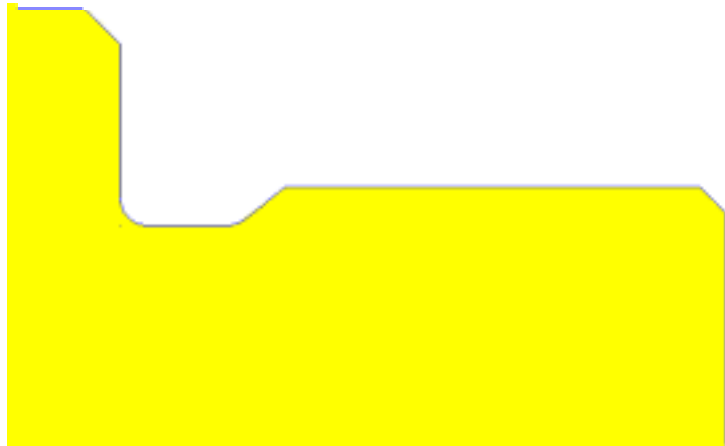

 Click the **edit NC code** icon on the **menu toolbar**.

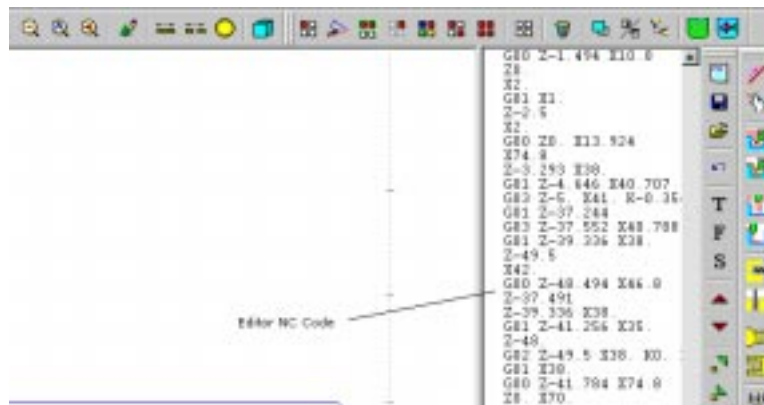

Lathe Tutorial 2

Use Lathe Thread Function



This is a lathe threading tutorial, we will draw a part, chamfer the end and then thread the part with a canned cycle thread.

Reading the [How to Thread Help page](#) before going through this tutorial will help your understanding for the following example.

Note: This help uses mm values.

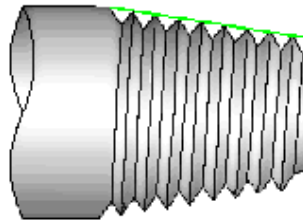

Step 1. Create a New Drawing



Click the **new drawing icon** on the **standard toolbar**.

You should have a blank drawing ready to draw your solid.

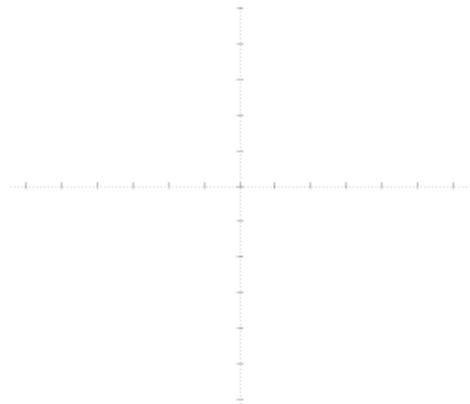

Now to make sure the NC file is clear



Click the **new NC icon** on the **NC editor toolbar**.

Click **Yes** or **No** to save your file.

Step 2. Drawing our Design

 Click the **line icon** on the **menu toolbar**.

 Click the **line by coordinates** icon on the **line menu toolbar**.

Enter the following values and click **OK**.

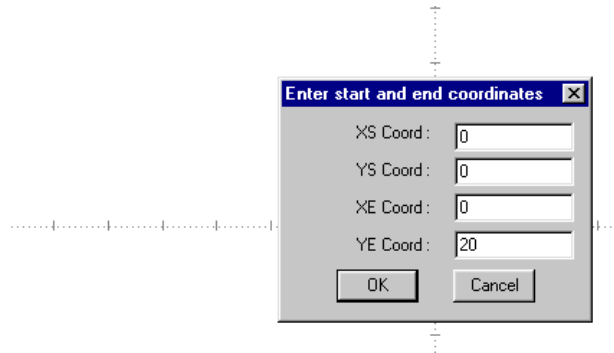

The dialog box titled "Enter start and end coordinates" has four input fields: XS Coord: 0, YS Coord: 0, XE Coord: 0, and YE Coord: 20. There are OK and Cancel buttons at the bottom.

Then enter the following and click **ok**.

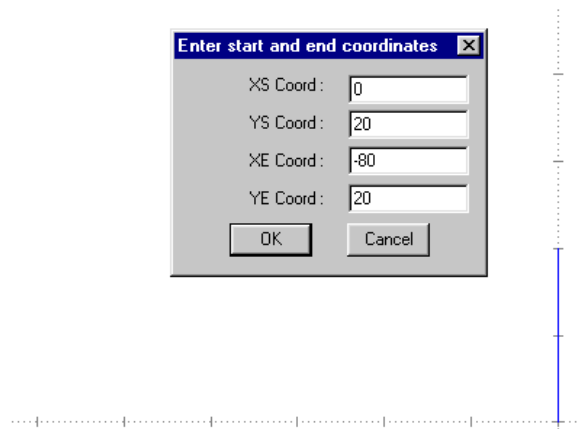

The dialog box now shows XS Coord: 0, YS Coord: 20, XE Coord: -80, and YE Coord: 20. A vertical blue line is drawn on the right side of the coordinate grid.

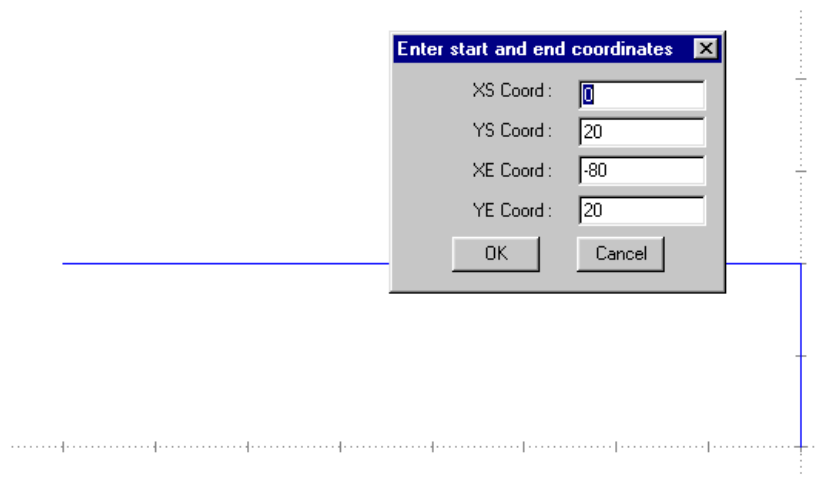

The dialog box now shows XS Coord: 0, YS Coord: 20, XE Coord: -80, and YE Coord: 20. A horizontal blue line is drawn on the left side of the coordinate grid.

Then click **cancel** to terminate line coordinate.



Click the **chamfer icon** on the **line menu toolbar**.

Then select the **front vertical line** by selecting and clicking with the **left mouse button**.

Then select the **second horizontal line**.



Enter the following **values** for the chamfer.

Then click **OK**.

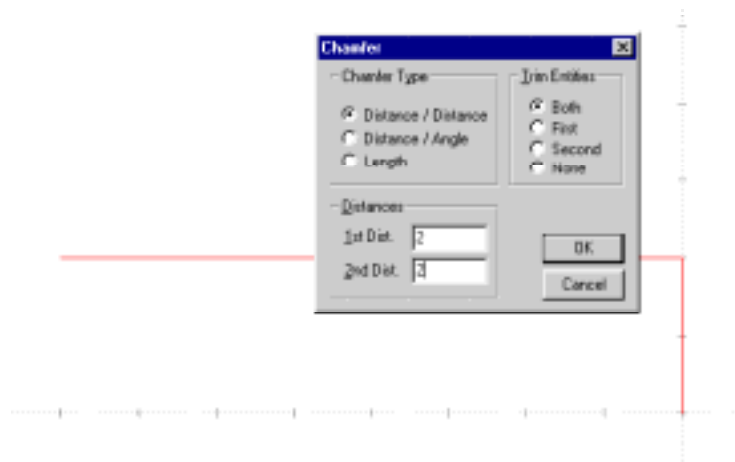

The chamfer is then created.

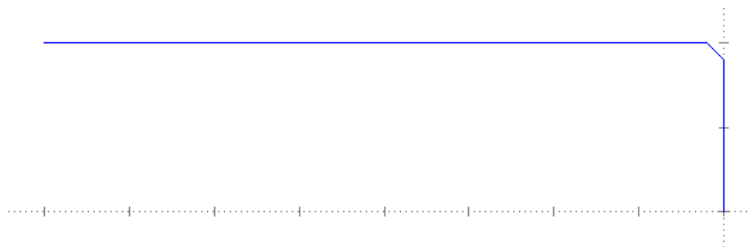

Step 4. Creating the Thread



Click the **home icon** on the **menu toolbar**.



Click the **point icon** on the **menu toolbar**



Click the **point along entity icon** on the **point menu toolbar**.

Then select the horizontal line near the chamfer end.

Enter a distance along line of **20** and click **OK**.



Click the **left mouse button** and the point will be created **20 mm** along that line.

Then click **cancel** to terminate the point along line dialogue.



Click the **home icon** on the **menu toolbar**.



Click the **edit icon** on the **menu toolbar**.



Click the **break at point icon** on the **edit menu toolbar**.

Select the **point** with the **mouse left button**.

Then select the horizontal line and it will be broken at that point.

We only want to thread along that line 20mm that is why we have broken it at this position.



The drawing is now completed and we will thread it.



Click the **thread icon** on the **NC CAM toolbar**.

Select the **line to be threaded** and it will turn red.

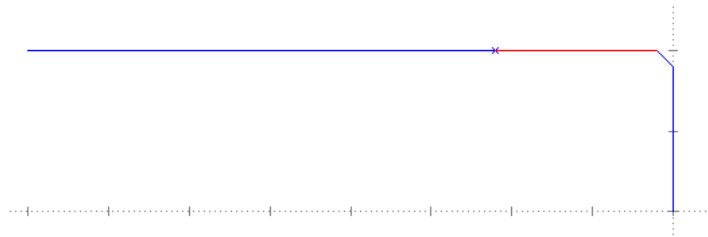

And the following dialogue will appear.

Select your **external threading tool** and click **next**.

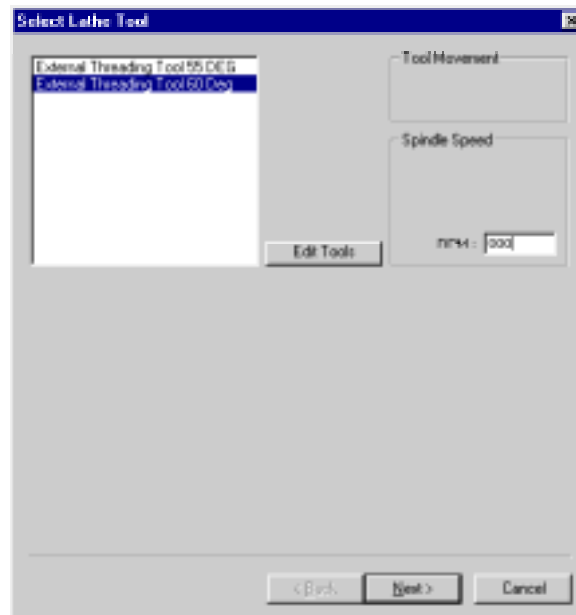

Enter your **clearance** valued and tag for G76 one line canned cycle then click **finish**.

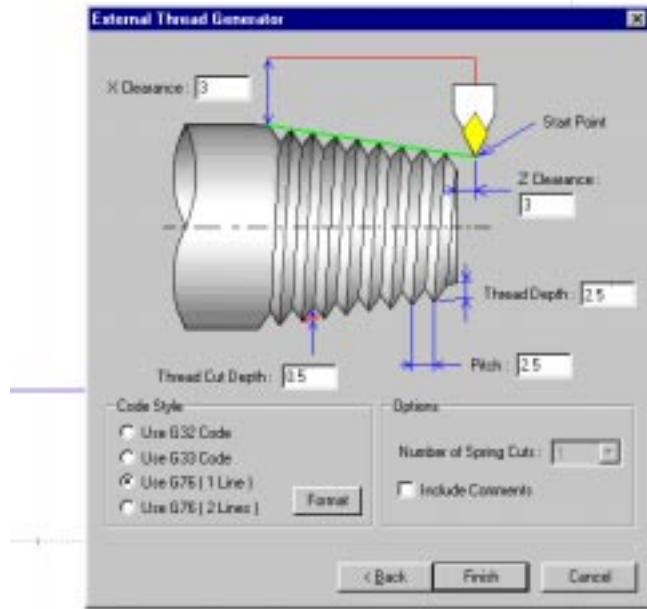

Click **OK**.



The thread is now created.

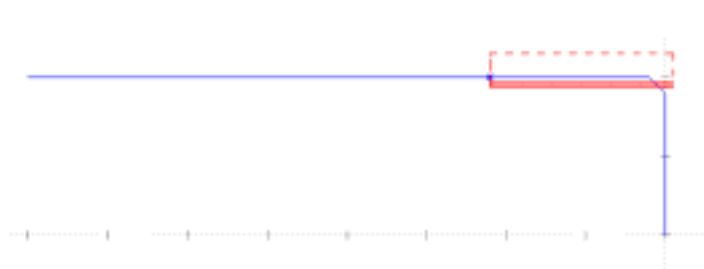

To simulate the thread:



Click the **lathe simulation icon** on the **NC CAM toolbar**.

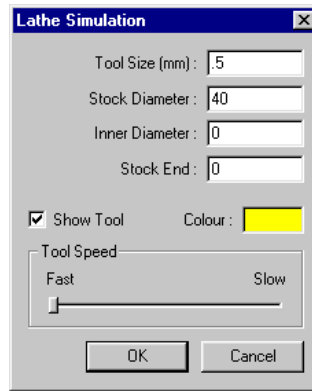

And the NC code is in the editor created as a canned cycle.

The other cycles G32 G33 and G76 2 line cycles are all done the same way.

Internal threads are created in the same manner by selecting the thread line.

```
O1234
(PROGRAM NUMBER)
(FANUC CONFIGURATION)
(AUSCAD2000 CNC FILE)
(PART NAME)
(DATE)
(TOOLS USED)
G00 T0505 M08
M41
G97 S800 M03
G00 Z1. X46.
G76 Z-22. X37.5 I0 K1250 D500 F2.5 A60
M09
G91 G28 Z0.
G91 G28 X0. Y0. M05
M30
%
```

IMPORTANT NOTE

External Threads.

The drawn line for an external thread is the outside diameter of the thread.

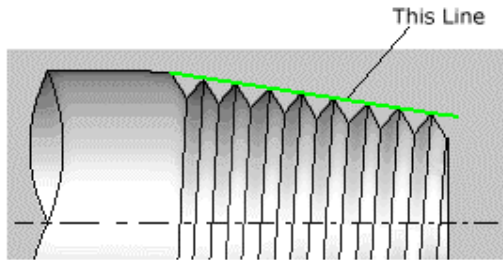

Internal Threads.

The drawn line for an internal thread is for the maximum diameter of the thread diameter not the bore diameter of the thread.

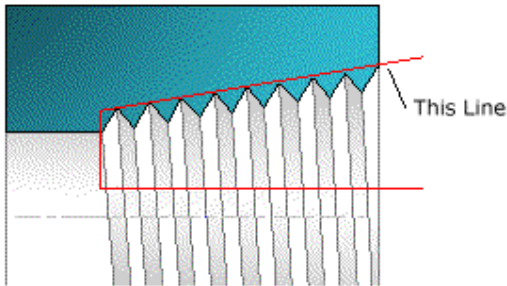

Lathe Tutorial 3

Use Lathe Groove Function

This is a lathe groove tutorial, we will draw a part and then rough and finish turn a groove in the part.

Note: This help uses mm values.

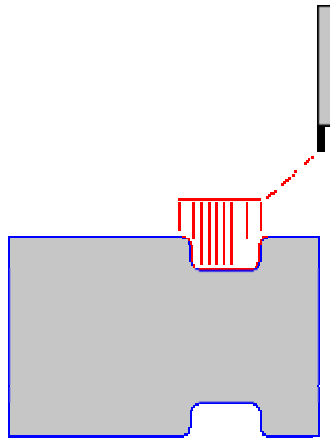

Step 1. Create a New Drawing



Click the **new drawing icon** on the **standard toolbar**.

You should have a blank drawing ready to draw your solid.

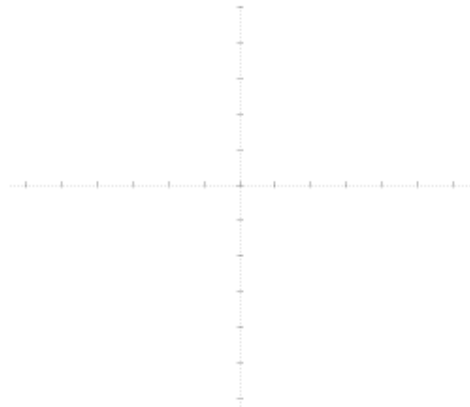

Now to make sure the NC file is clear



Click the **new NC icon** on the **NC editor toolbar**.

Click **Yes** or **No** to save your file.

Step 2. Creating a Design

 Click the **line icon** on the **menu toolbar**.

 Click the **line by coordinate icon** on the **NC editor toolbar**.

The following dialogue will appear.

Enter the following details and click **OK**.

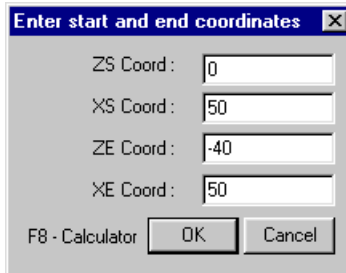

The dialog box titled "Enter start and end coordinates" has a close button (X) in the top right corner. It contains four input fields: "ZS Coord:" with value "0", "XS Coord:" with value "50", "ZE Coord:" with value "-40", and "XE Coord:" with value "50". At the bottom, there is a label "F8 - Calculator" and two buttons: "OK" and "Cancel".

Enter the following details and click **OK**.

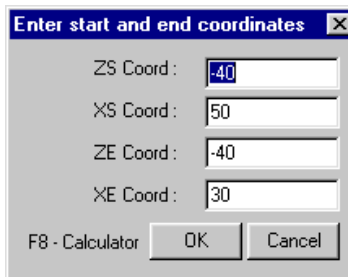

The dialog box titled "Enter start and end coordinates" has a close button (X) in the top right corner. It contains four input fields: "ZS Coord:" with value "-40", "XS Coord:" with value "50", "ZE Coord:" with value "-40", and "XE Coord:" with value "30". At the bottom, there is a label "F8 - Calculator" and two buttons: "OK" and "Cancel".

Enter the following details and click **OK**.

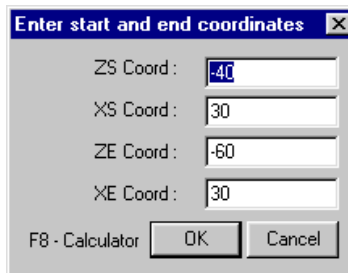

The dialog box titled "Enter start and end coordinates" has a close button (X) in the top right corner. It contains four input fields: "ZS Coord:" with value "-40", "XS Coord:" with value "30", "ZE Coord:" with value "-60", and "XE Coord:" with value "30". At the bottom, there is a label "F8 - Calculator" and two buttons: "OK" and "Cancel".

Enter the following details and click **OK**.

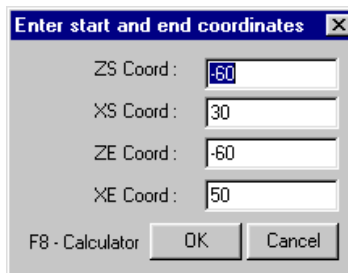

The dialog box titled "Enter start and end coordinates" has a close button (X) in the top right corner. It contains four input fields: "ZS Coord:" with value "-60", "XS Coord:" with value "30", "ZE Coord:" with value "-60", and "XE Coord:" with value "50". At the bottom, there is a label "F8 - Calculator" and two buttons: "OK" and "Cancel".

Enter the following details and click **OK**.

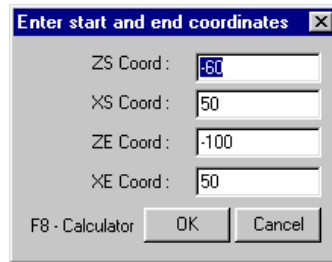

Click **cancel** to terminate the line by coordinates function.



Click the **home icon** on the **menu toolbar**.



Click the **arc and spline icon** on the **menu toolbar**.



Click the **fillet icon** on the **arc and spline menu toolbar**.

Select two lines like so:

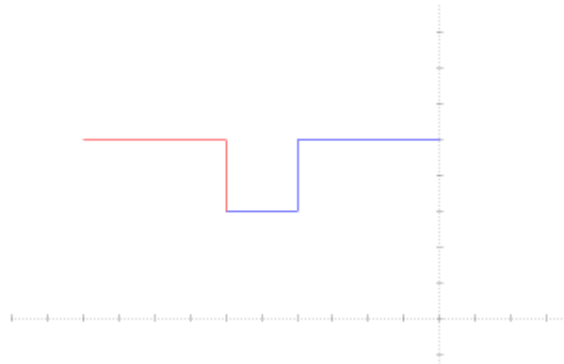

The following dialogue will appear.

Enter the following details and click **OK**.

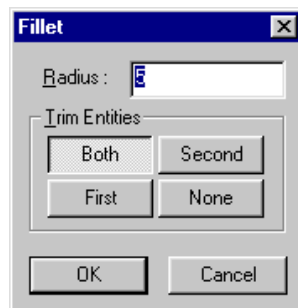

The fillet will then be created.

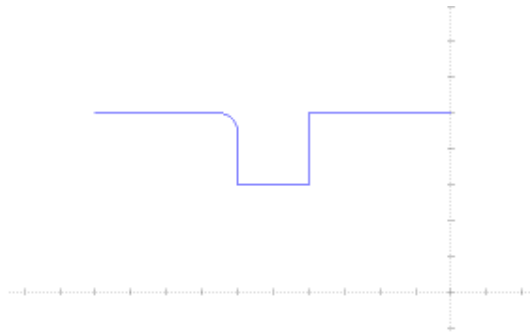

Now fillet the following edge.

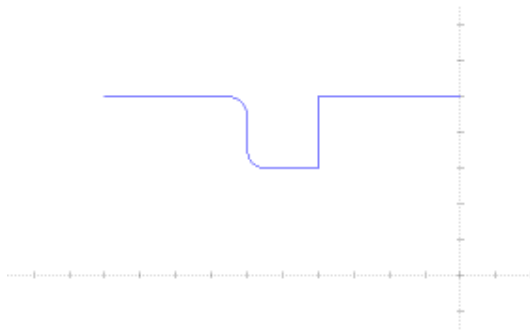

And the next.

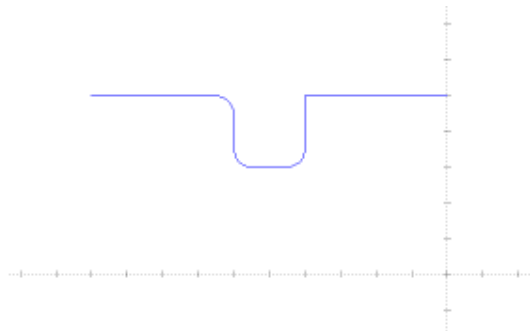

And the last.

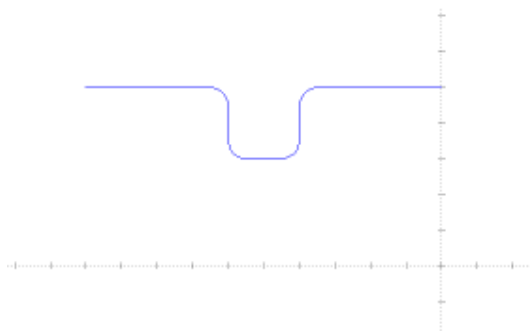

Step 3. Setting a Home Position

Firstly we will set the tool home position.

NC Setup Click the **NC Setup** menu on the **top menu**.

Click on the **coordinate options** tab.

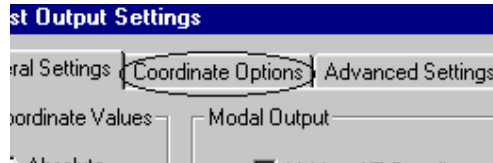

Set your **home position** and click **OK**.

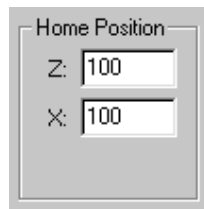

Step 4. Moving the Tool to Start Points



Click the **home icon** on the **menu toolbar**.



Click the **point menu icon** on the **menu toolbar**.



Click the **point by coordinate icon** on the **point menu toolbar**.

Enter the following details and click **OK**.

A dialog box titled "Enter coordinates" with a close button (X) in the top right. It contains two input fields: "Z-Coord:" with the value "20" and "X-Coord:" with the value "80". At the bottom, there are three buttons: "F8 - Calculator", "OK", and "Cancel".

Your point is now created.



Click the **move to a point icon** on the **NC CAM toolbar**.

Select **rapid** and click **OK**.

A dialog box titled "Feed or Rapid" with a close button (X) in the top right. It contains two radio buttons: "Feed" (unselected) and "Rapid" (selected). At the bottom, there is an "OK" button.

The position toolbar will now appear.



Click the **end of entity icon** on the **position toolbar**.

And select the **point** we just created.



So the tool will start at the home position of **100,100** then move to the point at **20,80** and then move on to start the tool path we will set next, setting the start up like is, is important so that tool doesn't cut through the job to start.

Step 5. Groove Roughing



Click the **groove roughing icon** on the **NC CAM toolbar**.

Set the **lathe tool** and click **next**.

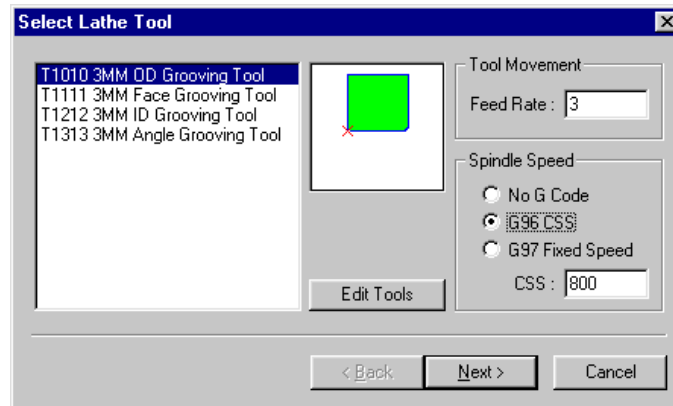

Set the **boundary of the toolpath** and click **next**.

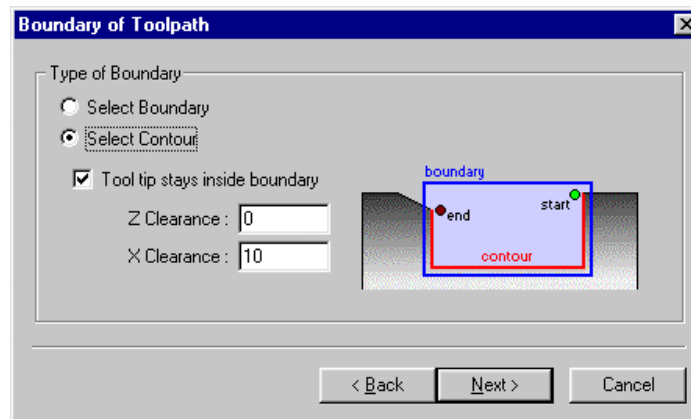

Set the **grooving options** and click **finish**.

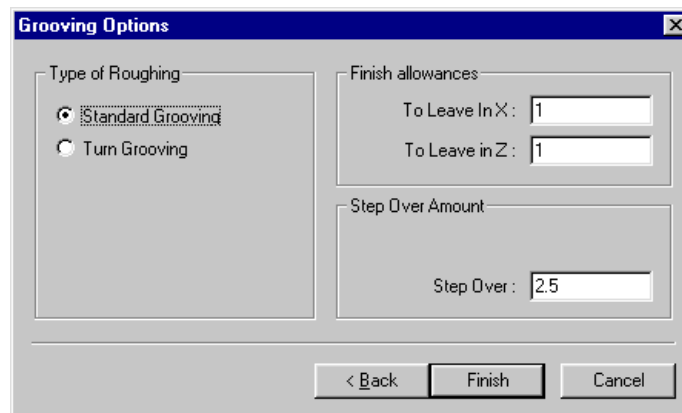

Select the **first entity**, which is marked here

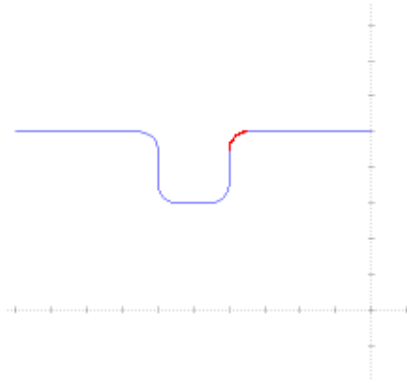

Set the **arrow** in this direction.

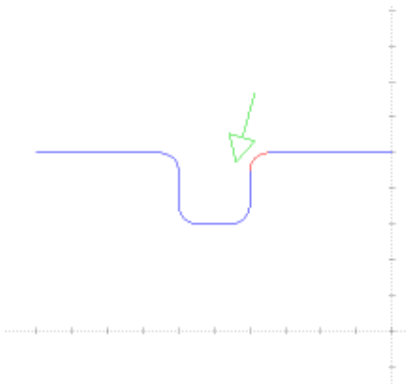

Select the **last entity** shown here.

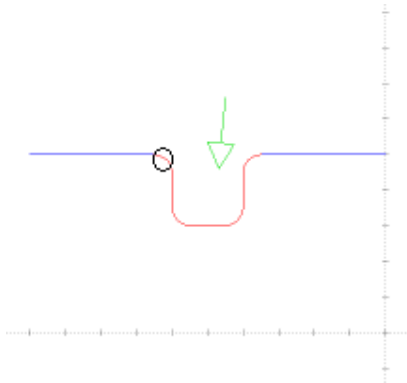

Now click the **right mouse button** to accept these boundaries.

the following dialogue will appear.

Click **YES** if the offset and direction are ok.

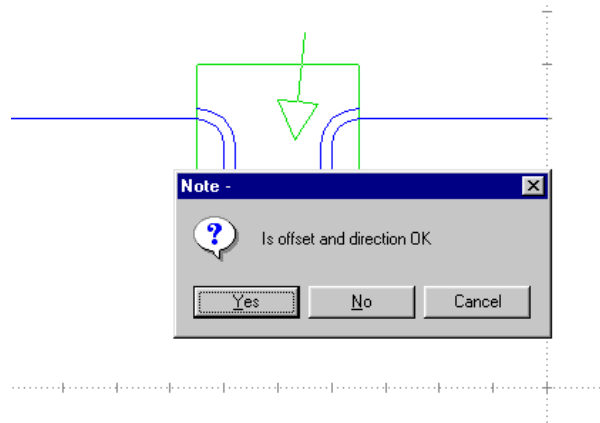

Your roughing toolpath will then be created.

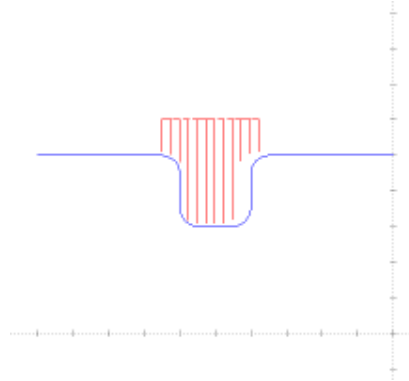

Step 6. Groove Finishing

 Click the **groove finishing icon** on the **NC CAM toolbar**.

Set the **lathe tool** and click **next**.

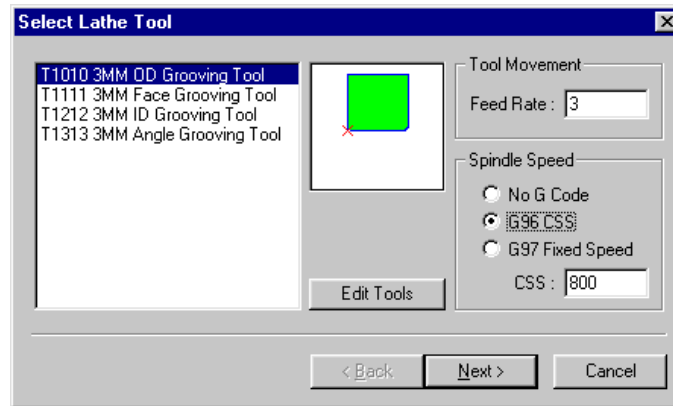

Set the **boundary of the toolpath** and click **next**.

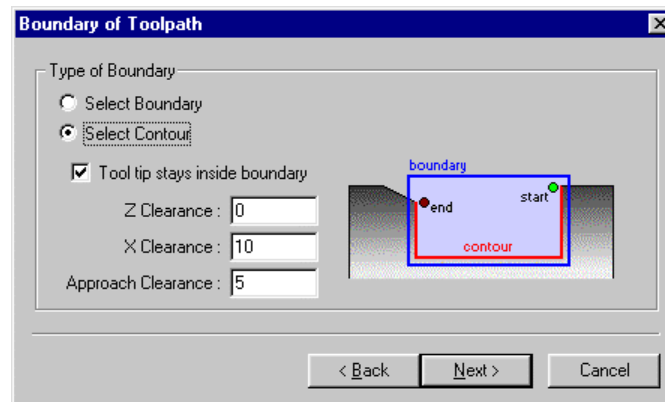

Set the **grooving options** and click **finish**.

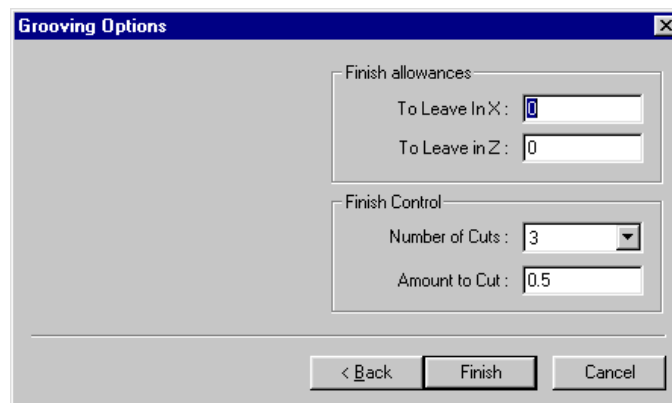

Select the **first entity**, which is marked here

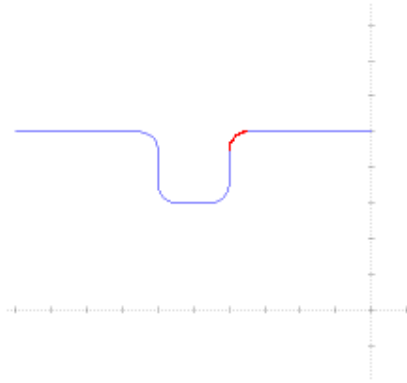

Set the **arrow** in this direction.

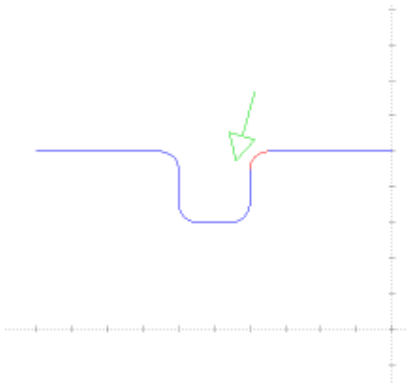

Select the **last entity** shown here.

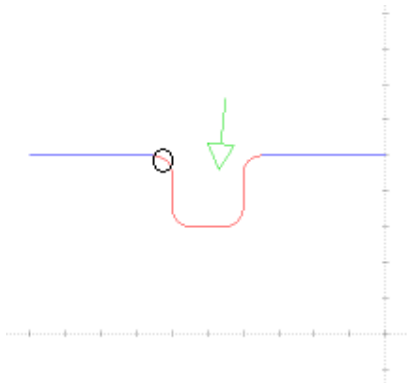

Now click the **right mouse button** to accept these boundaries.

The following dialogue will appear.

Click **YES** if the offset and direction is OK.

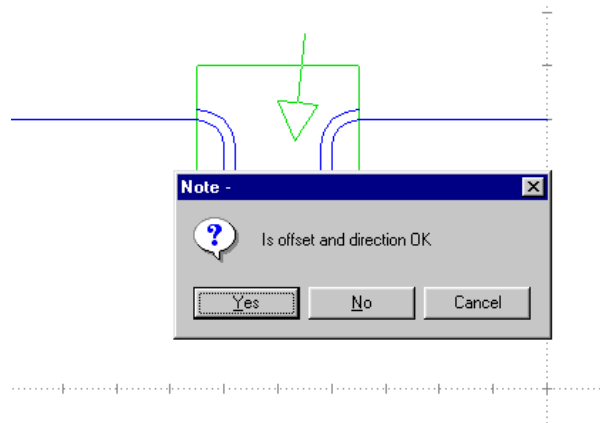

The finish toolpath is then created.

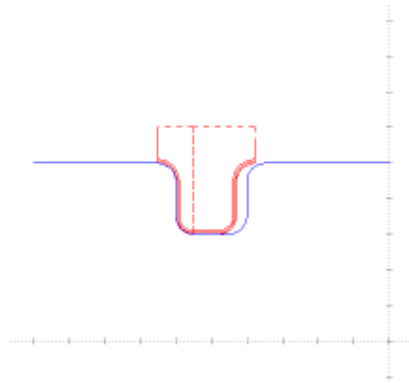

Step 7. Simulating the Toolpath



Click the **lathe simulation icon** on the **NC CAM toolbar**.

The following dialogue will appear.

Enter the following details and click **OK**.

The dialog box titled "Lathe Simulation" contains the following fields and controls:

- Tool Size (mm): 10
- Stock Diameter: 120
- Inner Diameter: 0
- Stock End: 10
- Show Tool
- Colour: Yellow
- Tool Speed: A slider control with "Fast" and "Slow" labels, currently positioned near "Fast".
- Buttons: OK and Cancel.

The toolpath is then simulated.

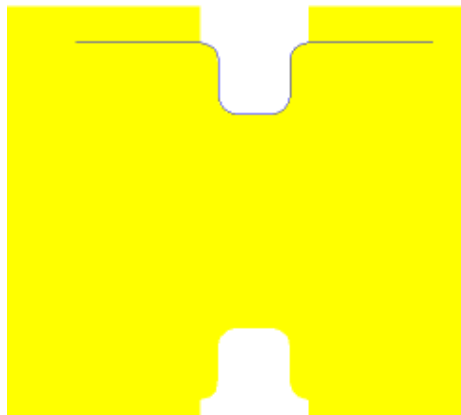

Lathe Tutorial 4

Use Lathe Drill Funtion



This is a lathe drilling tutorial, we will draw a part and then drill a hole in the part.

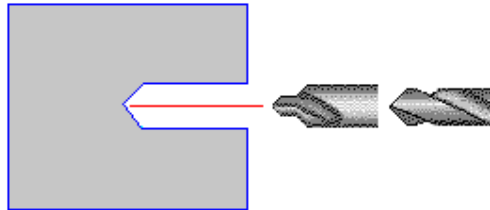

Step 1. Create a New Drawing

 Click the **new drawing icon** on the **standard toolbar**.

You should have a blank drawing ready to draw your solid.

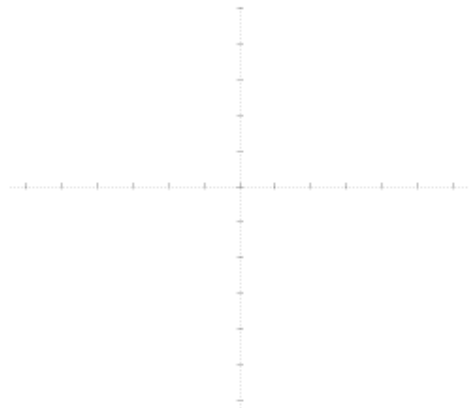

Now to make sure the NC file is clear

 Click the **new NC icon** on the **NC editor toolbar**.

Click **Yes** or **No** to save your file.

Step 2. Create a Design

 Click the **line icon** on the **menu toolbar**.

 Click the **line by coordinates** icon on the **line menu toolbar**.

Enter the following values and click **OK**.

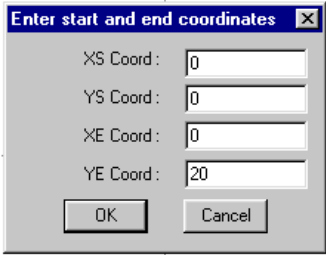

Enter start and end coordinates

XS Coord:	0
YS Coord:	0
XE Coord:	0
YE Coord:	20

OK Cancel

Then enter the following and click **OK**.

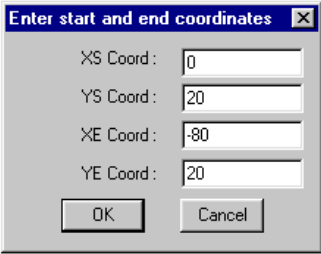

Enter start and end coordinates

XS Coord:	0
YS Coord:	20
XE Coord:	-80
YE Coord:	20

OK Cancel

Now click cancel to **cancel** the coordinates dialogue.



Step 3. Drilling the Part



Click the **drilling cycle icon** on the **NC CAM toolbar**.

Select your **drill** and click **next**.

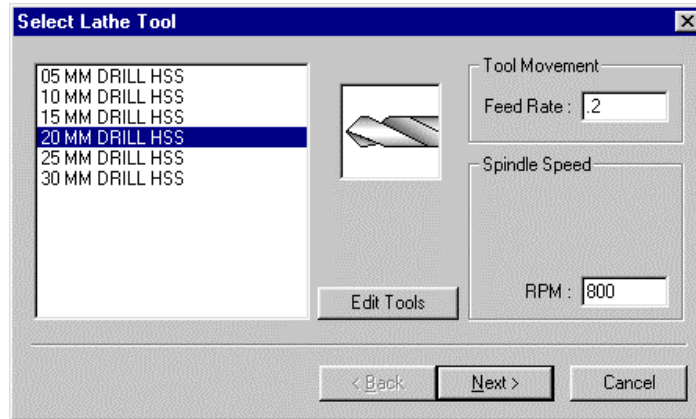

Set your **settings**.

Then click **finish**.

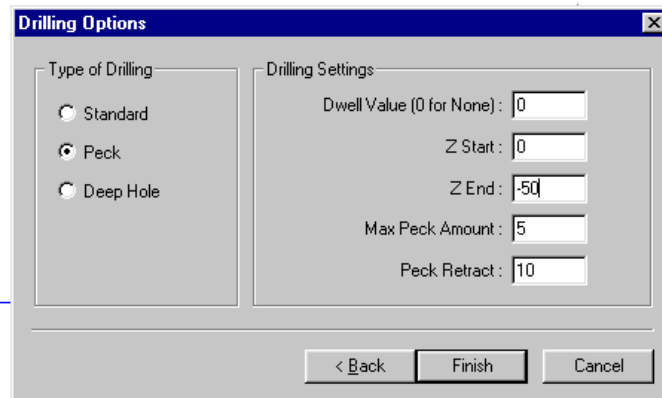

The code is then created and placed in the NC editor.

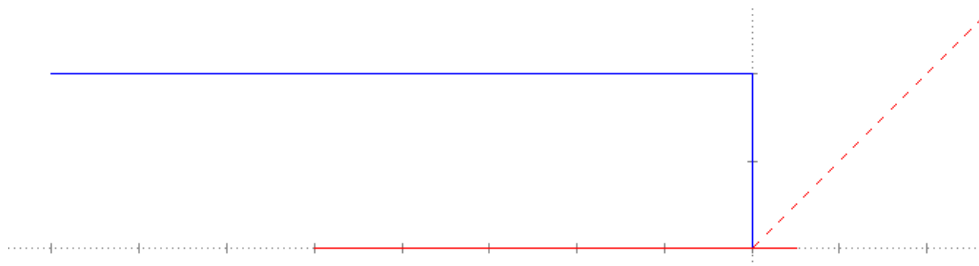

Step 4. Simulation



Click the **lathe simulation icon** on the **NC CAM toolbar**.

The "Lathe Simulation" dialog box contains the following settings:

- Tool Size (mm): .5
- Stock Diameter: 40
- Inner Diameter: 0
- Stock End: 0
- Show Tool
- Colour: Yellow
- Tool Speed: A slider control with "Fast" on the left and "Slow" on the right. The slider is positioned near the "Fast" end.

Buttons: OK, Cancel

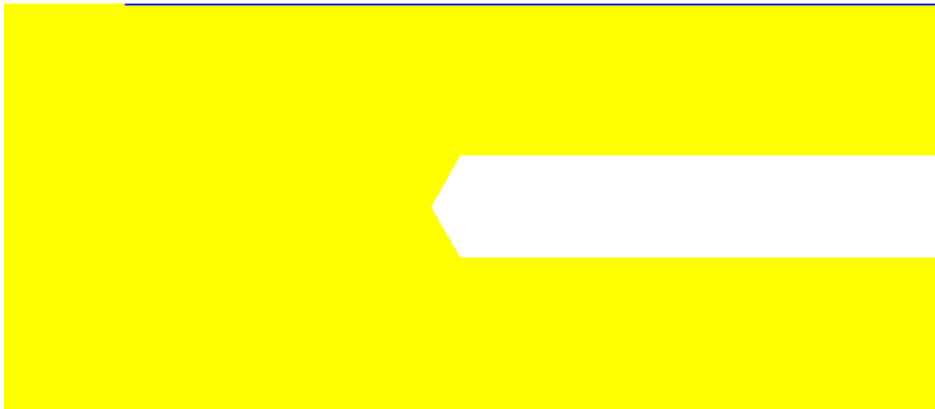

Lathe Tutorial 5

Use Lathe Part Off Function

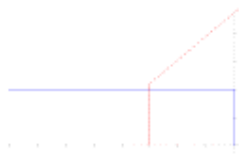

This is a lathe parting off tutorial, we will draw a part and then part off the part.

Note: This help uses mm values.

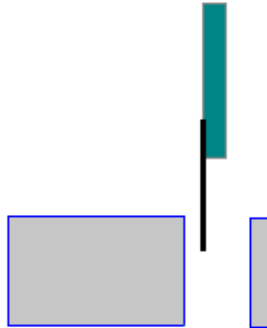

Step 1. Create a New Drawing



Click the **new drawing icon** on the **standard toolbar**.

You should have a blank drawing ready to draw your solid.

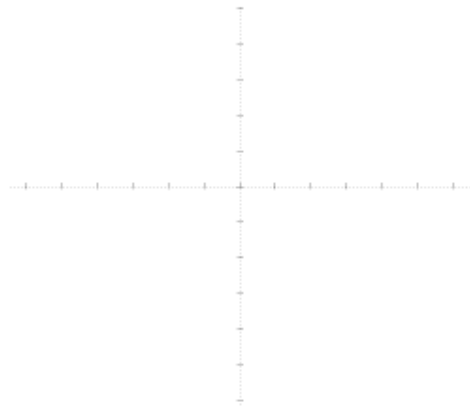

Now to make sure the NC file is clear



Click the **new NC icon** on the **NC editor toolbar**.

Click **Yes** or **No** to save your file.

Step 2. Draw a Design

 Click the **line icon** on the **menu toolbar**.

 Click the **line by coordinates** icon on the **line menu toolbar**.

Enter the following values and click **OK**.



Then enter the following and click **ok**.

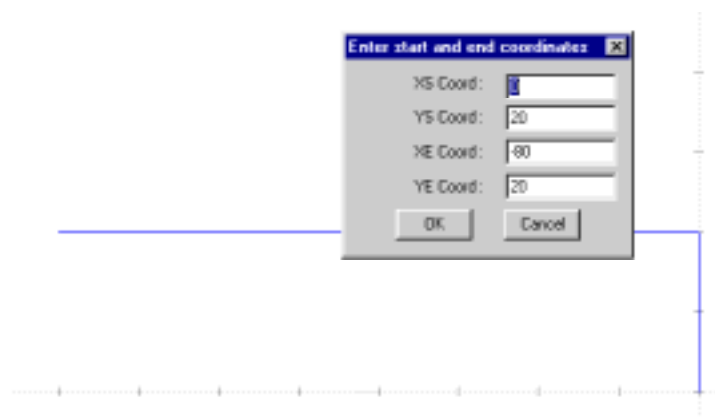

Then enter the **next coordinates**

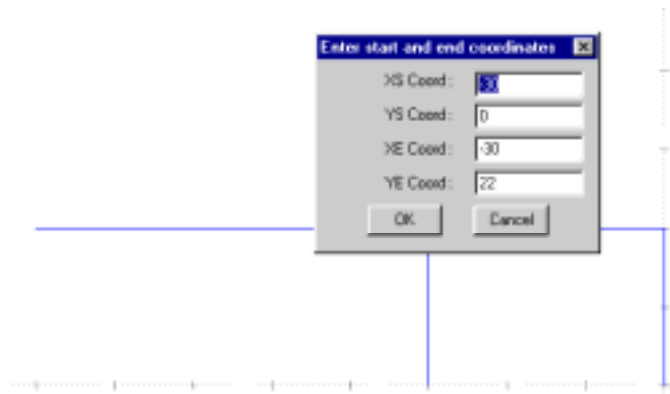

Then click **cancel** to terminate coordinates

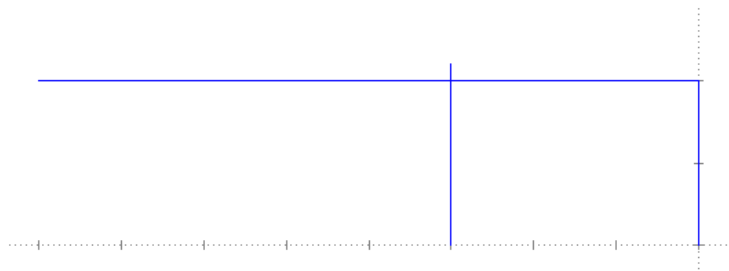

Step 3. Parting off With Lathe

We are now ready to part off, at this line.



Click the **parting cycle icon** on the **NC CAM toolbar**.

The following dialogue will appear.

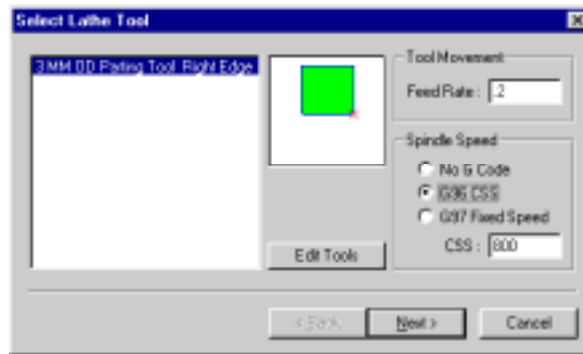

Select your **parting tool** and click **next**

Set the **diameter required** and **dwell** if any is required.

Then click **finish**.

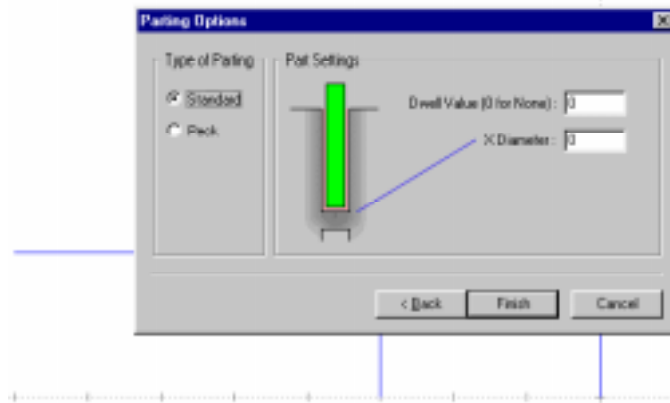

Click the **end point icon** on the **position toolbar**.

And select the end point of this line.



The code is then created.

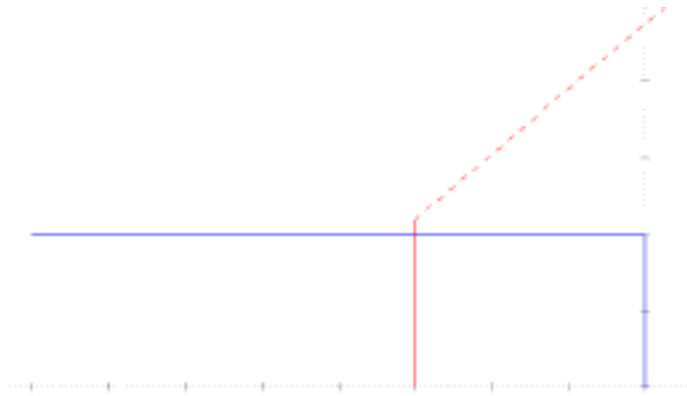

Step 4. Simulation



Click the **lathe simulation icon** on the **NC CAM toolbar**.

The 'Lathe Simulation' dialog box contains the following settings:

- Tool Size (mm): 5
- Stock Diameter: 40
- Inner Diameter: 0
- Stock End: 0
- Show Tool
- Colour: Yellow
- Tool Speed: A slider control set to the 'Fast' position.

Buttons: OK, Cancel

